



SkyView HDX

System Installation Manual

STC SA02594SE

Document # 103261-000

Rev T

12/3/2025

Copyright © 2025 by Dynon Avionics, Inc.

Permission to print this manual is granted to third parties.

Contact Information

Dynon Avionics, Inc.
19825 141st Place NE
Woodinville, WA 98072

Technical Support

Phone: +1 (425) 399-7742, 8:00 AM – 5:00 PM (Pacific Time) Monday – Friday
Email: support@dynoncertified.com

Sales

Phone: +1 (425) 650-1269, 8:00 AM – 5:00 PM (Pacific Time) Monday – Friday
Email: sales@dynoncertified.com

Find Us on the Web

dynoncertified.com – Dynon Certified homepage
dynoncertified.com/docs – Product documentation
dynoncertified.com/download – Software updates for products
dynoncertified.com/support – Support resources
dynoncertified.com/register – Register your Dynon Avionics product

Stay in Touch

dynoncertified.com/newsletter – Sign up to receive Dynon’s newsletter
forum.flydynon.com – Dynon-hosted forum for customers and pilots
preflight.dynon.com – Dynon’s blog
facebook.com/dynonavionics
instagram.com/dynonavionics
twitter.com/dynon

Videos and Training

youtube.com/DynonAvionics – Training, events, and other videos on YouTube

Copyright

©2025 Dynon Avionics, Inc. All rights reserved. No part of this manual may be reproduced, copied, transmitted, disseminated, or stored in any storage medium, for any purpose without the express written permission of Dynon Avionics. Dynon Avionics hereby grants permission to download a single copy of this manual and of any revision to this manual onto a hard drive or other electronic storage medium to be viewed for personal use, provided that such electronic or printed copy of this manual or revision must contain the complete text of this copyright notice and provided further that any unauthorized commercial distribution of this manual or any revision hereto is strictly prohibited.

Information in this document is subject to change without notice. Dynon Avionics reserves the right to change or improve its products and to make changes in the content without obligation to notify any person or organization of such changes. Visit the Dynon Avionics website (dynon.com) for current updates and supplemental information concerning the use and operation of this and other Dynon Avionics products.

Revision History

Rev	Date	ECO	Description
T	12/03/2025	401867	<ul style="list-style-type: none"> Updated Sections 12.2.3, 12.2.4, 12.2.10, 12.2.11, 12.2.13, and 30.2 for the new fluid pressures sensors. Replaced figure of ammeter shunt in Section 12.2.16 with one more detailed.
S	05/12/2025	396113	<ul style="list-style-type: none"> Removed reference to SV-NET-TEST cable from Table 3
R	02/25/2025	394333	<ul style="list-style-type: none"> Added a note about certified use of a Standby Flight Display to Section 3: System Overview.
Q	10/11/2024	378658	<ul style="list-style-type: none"> Reversed order of Revision History to place most recent changes at top of table. Removed discontinued '10" Avionics Tray' from Section 5. Added Kavlico Manifold Pressure Sensor to Table 19 in Section 12.2.4. Renamed Section 12.2.10 to differentiate old sensor from new Kavlico Manifold Pressure Sensor. Added Section 12.2.11: Kavlico Manifold Pressure Sensor, subsequent sections renumbered. Updated Figure 71 in Section 12.8.3 to show new format of combined CHT/EGT indicator. Revised Figure 111 in Section 17.1 for new OLED SV-COM-PANELs. Removed discontinued 'I Cloth' from Section 29.1. Added Kavlico Manifold Pressure Sensor to Table 52 in Section 30.2.
P	09/05/2023	388546	<ul style="list-style-type: none"> Revised Section 22: SV-AP-TRIMAMP Trim Motor Adapter to point to Dynon's AML doc for applicable aircraft.
O	06/05/2023	378880	<ul style="list-style-type: none"> Updated and simplified expression of SkyView component weights in Table 6. Revised verbiage in Section 2.4: Pre-installation Information pertaining to mechanic ratings. Revised verbiage in Section 3: System Overview. Revised Figure 3 in Section 3.1: Integrated System. Revised Table 3: in Section 3.4 Wire Harnesses & Network Cables to list all available harnesses and cables. Revised Section 12.3: Contacts to specify use of resistors for general purpose signals above 5v. Renamed and Revised Section 12.8: SkyView HDX Engine Bottom Band to EMS Screen Layout Editor to include all engine pages and twin-engine widgets. Revised verbiage in Section 13.1: WAAS Data Reception. Revised Section 22: SV-AP-TRIMAMP Trim Motor Adapter to specify interface with Edo-Aire 1C469-6-292 electric pitch trim motors installed under STC SA1786SW in Beechcraft Baron 58 airplanes. Revised procedure in Section 22.2.1: SV-TRIMAMP Wire Harness to fix pin number. Revised and re-named subsections in Section 27: Display Operation with updated screenshots and restructured content to be more readable. Also replaced "joystick" with "knob" throughout section.
N	06/01/2023	386803	<ul style="list-style-type: none"> Section 4.3.2: replaced EFIS-D10A with standby display. Section 4.4 added figure of D30. Section 26: added reference to D30 Installation and Maintenance Manual.
M	01/19/2022	377368	<ul style="list-style-type: none"> Revised introduction of Section 22: SV-AP-TRIMAMP Trim Motor Adapter to include factory installed Cessna pitch trim motors.
L	01/03/2022	374720	<ul style="list-style-type: none"> Revised Contact Information section and links within doc with current info and addresses. Revised Table 9: Available Installation Aids with correct P/N for COM Radio Stack Module Mounting Kit.
K	11/23/2021	376295	<ul style="list-style-type: none"> Revised Section 22: SV-AP-TRIMAMP Trim Motor Adapter to specify interface with Edo-Aire 1C469-6-662 electric pitch trim motors installed under STC SA3205SW-D in Beechcraft Bonanza A36 airplanes.

Rev	Date	ECO	Description
J	06/10/2021	372294	<ul style="list-style-type: none"> Revised Tables and Figures in Section 5: Installation Aids with current hardware configurations.
I	05/11/2021	364748	<ul style="list-style-type: none"> Replaced Dynon logo with Dynon Certified logo. Updated and moved old References section to Section 1.7: Reference Documents. Updated old Section 1: Intro per current end-user doc format. <ul style="list-style-type: none"> Moved old Sections 1.3, 1.4, 1.5, 1.6 to Section 2: Important Information. Added new Section 1.5: Mechanical Drawings and Section 1.6: Terminology. Added new Section 2: Important Information per current end-user doc format. Subsequent sections renumbered. <ul style="list-style-type: none"> Updated old Sections 2.1, 2.2, 2.3, 2.5 per current doc template. Added new Section 2.4: Pre-installation Information. Updated old Section 2 per current SkyView HDX system integration: <ul style="list-style-type: none"> Removed old Sections 2.1, 2.2, 2.3, 2.4, 2.7, 2.8, 2.11.4. Added new Section 3.1: Integrated System. Updated old Section 2.5. All instances to EFIS-D10A changed to Standby Flight Display and replaced all information for Standby Flight Displays with reference to the <i>EFIS-D10A Installation and Maintenance Manual</i>. Added new Section 5: Installation Aids. Subsequent sections renumbered. Updated and moved old Section 6.1 to Section 5: Installation Aids. Removed Section 6.2.9.10: Val Avionics NAV 2000. Subsequent section headings renumbered. Updated Section 14:3: Transponder Related SkyView Display Settings to include ADS-B OUT 'Off' and Flight ID settings. Revised FAA website URL for ADS-B Out Report in Section 14.4.1.1. Updated Section 15: SV-COM-X83 to include SV-COM-X25. Reference to SV-COM-X83 throughout entire document updated to include SV-COM-X25. Updated Section 16.4: SV-ADSB-472 Related SkyView Display Settings to include Ghost Target settings. Added new Section 22: SV-AP-TRIMAMP Autopilot Trim Amplifier. Subsequent sections renumbered. Updated Section 23: AOA Probe with language for twin-engine airplanes. Added Section 24: SV-NET-HUB. Subsequent sections renumbered. Added Section 25: Panel-Mount USB Port. Subsequent sections renumbered. Revised Section 29.9: Instructions for Continued Airworthiness to reference the SkyView HDX General Maintenance Manual. Added new Section 30.7: SV-COM-T25 Specifications. Subsequent sections renumbered. Updated Appendix B: Specifications to include SV-AP-TRIMAMP. Updated Appendix C: Wiring and Electrical Connections to include SV-AP-TRIMAMP and SV-COM-X25. Updated Appendix E: Serial Data Output to be procedural.
H	10/28/2020	360446	<ul style="list-style-type: none"> Updated Section 3: Instrument Panel Design with an additional Important Note about FAA-compliant installations.
G	09/23/2020	356787	<ul style="list-style-type: none"> Updated Section 3 and 3.2 per with notes about instrument panel materials and fasteners. Added Section 7.5.3 AoA In-Flight Calibration. Updated Section 7.6 with new system function.

Rev	Date	ECO	Description
F	08/6/2020	347671	<ul style="list-style-type: none"> Section 10.3.1 updated with correct part number for Oil Temp Sensor Sections 10.1, 10.3, 10.3.1, 10.8, 10.9 updated for dual EMS installation, twin engine EMS configuration file requirement, and twin-engine display layouts. Added new Section 4.4 for required display configurations information. Added new Section 20 for Angle of Attack (AoA) sensor installation and configuration information. Added Section 1.4 STC Approval and 1.5 Third-Party Products. Revised section 13.2.2 ARINC Third-Party Connection to include Garmin GPS 175 connection and configuration instructions.
E	05/06/2020	339966	<ul style="list-style-type: none"> Change Bars indicate new information or significant changes to existing information. Created new Section 10.2.4 for Certified Sensors table. Subsequent Section 10 headings renumbered. Updated 10.2.11, and 10.2.12 with new fluid sensors sold by Dynon. Added new Section 3.2: Instrument Panel Material Requirements. Subsequent Section 3 headings renumbered.
D	07/02/2019	327067	<ul style="list-style-type: none"> Revision Bars indicate new information or significant changes to existing information. Revised Table 64 - SV-COM-PANEL D15M Pinout to meet SV-COM-X83 Transceiver wiring requirements. Added Section 2.0: Instrument Panel Design. Added Section 2.1: Regulatory Considerations. Added Section 2.2: Volumetric Requirements. Section 1 (old) moved to fore matter content. Section 1.10 (old) removed because content outdated. Section 2.1-5 (old) moved to Section 1 (new). Section 2.6 (old) removed because content outdated. Section 2.7 (old) renamed and moved to Section 1.15 (new). Added Section 3.1 (new): Avionics Tray Installation. Sections 3, 6, 8-19 re-organized to better match typical order of assembly. Sections 4.10-13 (old) removed because content outdated. Section 5 (old) moved to Section 21 (new). Section 7 (old) moved to Section 22 (new). Section 8.5.18 (old) removed because outdated. Section 11.1.1 (old) moved to Section 20 and updated. Section 11.1.2 (old) moved to Section 19 and updated. Section 27 (old) removed because no longer applicable. Section 23.3.2 (old) renamed. Section 23.3.3 (old) removed because no longer applicable. Tables 6, 35, 39 (old) removed because outdated. Figure 59 (old) removed because outdated. Replaced all component mounting dimension figures with updated drawings. All subsequent sections, figures, tables renumbered. Edited new content, fixed headers/footers, fixed cross-references. Incorporated internal review feedback. Updated doc in response to FAA review feedback, specifically Sections 2.3.1, 2.3.2, 3.1.2, 10.8.3.2, 12.1.2, 12.4, 14.3, 21.7, 22.2, 25.4.1, 25.4.2, 25.6.7.
C	04/04/2019	326312	<ul style="list-style-type: none"> Created Section 8.5.22 Landing Gear Position Indication. Revised Landing Gear information in Section 8.6 Contacts to address logic change for landing gear to include GEAR 1, GEAR 2, GEAR 3, and GEAR 4. Adjusted formatting on title page. Updated references table.
B	09/31/2018	312857	<ul style="list-style-type: none"> Added Second Display, VHF COM, AP Panel, Knob Panel. Added more specific instructions on mounting SkyView HDX per STC02594SE.
A	03/05/2018		<ul style="list-style-type: none"> Initial Release

Table of Contents

1	Introduction	1
1.1	Product Delivery and Warranty	1
1.2	Product Registration	1
1.3	Using this Manual	1
1.4	Manual Iconography	2
1.5	Mechanical Drawings	2
1.6	Terminology	2
1.7	Reference Documents	4
2	Important Information	5
2.1	STC Approval	5
2.2	Third-Party Products	5
2.3	Installation Compliance.....	6
2.4	Pre-installation Information	6
2.5	Installation Record.....	7
3	System Overview	8
3.1	Integrated System.....	8
3.2	SkyView Network	13
3.3	Other System Connections	14
3.4	Wire Harnesses & Network Cables.....	15
3.5	Power Protection.....	16
3.6	Specifications	16
3.7	Bench Test Quick Start	19
4	Instrument Panel Design	22
4.1	Regulatory Considerations	22
4.2	Instrument Panel Material Requirements	23
4.3	Primary Flight Information	24
4.4	Volumetric Requirements	29
5	Installation Aids	37
5.1	Avionics Trays.....	41
5.2	Module Stacking Kits.....	48
5.3	Radio Stack Module Mounting Kit	50
6	SkyView HDX Display Units	55
6.1	Mechanical Installation	57
6.2	Electrical Installation.....	59
6.3	Required Display Configuration	76
6.4	Other Display Configuration	78
7	SV-KNOB-PANEL Control Panel	86
7.1	Mechanical Installation	87
7.2	Electrical Installation.....	88
7.3	Post Installation Checks	88
8	SV-BAT-320 Backup Battery	89
8.1	Mechanical Installation	90
8.2	Electrical Installation.....	91
8.3	Charging the SV-BAT-320.....	92

8.4	Battery Status Icon	93
8.5	Detailed Battery Status Check	94
8.6	Initial SV-BAT-320 Test	95
8.7	SV-BAT-320 Specifications	96
8.8	Returning an SV-BAT-320 to Dynon Avionics for Exchange (Warranty Replacement)	97
9	SV-ADAHRS-200 ADAHRS	98
9.1	Mechanical Installation	98
9.2	Electrical Installation.....	102
9.3	Compass Calibration	102
9.4	PFD-Related Settings.....	106
9.5	Other ADAHRS Calibrations	107
9.6	Pitot / Static Checks	107
10	SV-MAG-236 Remote Magnetometer	109
10.1	Mechanical Installation	109
10.2	SV-OAT-340 Connected to SV-MAG-236	111
10.3	Electrical Installation.....	112
10.4	Compass Calibration	112
11	SV-OAT-340 OAT Sensor	117
11.1	Mechanical Installation	117
11.2	Electrical Installation.....	118
12	SV-EMS-220 Engine Monitoring System	119
12.1	Mechanical Installation	119
12.2	Electrical Installation.....	121
12.3	Contacts	146
12.4	General Purpose Thermocouple	148
12.5	Engine Information	148
12.6	EMS Configuration Files	149
12.7	EMS Sensor Input Mapping	149
12.8	EMS Screen Layout Editor.....	160
13	SV-GPS-2020 GPS Antenna/Receiver	170
13.1	WAAS Data Reception	171
13.2	Mechanical Installation	171
13.3	Electrical Installation.....	173
13.4	Serial Port 5 Configuration (SV-GPS-2020 only).....	174
13.5	Testing / Troubleshooting SV-GPS-2020 Installation	174
13.6	Additional Configuration Required for Compliance with FAA 2020 ADS-B Out Mandate	178
14	SV-XPNDR-261 Transponder	179
14.1	Mechanical Installation	180
14.2	Electrical Installation.....	182
14.3	Transponder-Related SkyView Display Settings	190
14.4	Equipping for FAA 2020 ADS-B Out Mandate Compliance (U.S. Only)	198
14.5	SV-XPNDR-261 Software Updates	200
14.6	SV-XPNDR-261 Post Installation Checks	205
14.7	Transponder Warnings (Transponder Self Diagnostics)	206
14.8	Performing Transponder Checks	207
	Dynon Avionics SV- SV-GPS-2020 Compliance Statements	208
15	SV-ARINC-429 ARINC Module	209

15.1	Mechanical Installation	209
15.2	Electrical Installation.....	211
15.3	SV-ARINC-429 Related Settings.....	213
16	SV-ADSB-472 ADS-B IN Receiver	215
16.1	Mechanical Installation	216
16.2	Electrical Installation.....	218
16.3	Antenna Selection and Installation	220
16.4	SV-ADSB-472 Related SkyView Display Settings.....	224
16.5	Post Installation Checks	224
17	SV-COM-X25 and SV-COM-X83 COM Radios	226
17.1	Mechanical Installation	226
17.2	Electrical Installation.....	230
17.3	SkyView System Settings for SV-COM-X25/X83	235
17.4	Post Installation Checks	237
18	Autopilot Servos	238
18.1	Overview.....	238
18.2	Autopilot Servo Initial Setup.....	239
19	SV-AP-PANEL Autopilot Control Panel	245
19.1	Mechanical Installation	246
19.2	Electrical Installation.....	247
20	SV-BUTTON-LEVEL Autopilot Level Button	248
20.1	Mechanical Installation	249
20.2	Electrical Installation.....	250
20.3	Considerations for SkyView Systems with Multiple SkyView Displays	250
20.4	Installation Options on Multiple SkyView Displays	250
20.5	Troubleshooting	251
21	Autopilot Disconnect Button	252
21.1	Yoke-mounted Button.....	252
21.2	Panel-mounted Button.....	252
22	SV-AP-TRIMAMP Trim Motor Adapter	255
22.1	Mechanical Installation	255
22.2	Electrical Installation.....	257
22.3	Configuration	261
23	Angle of Attack Probe	263
23.1	Mechanical Installation	263
23.2	AoA System Configuration.....	264
24	SV-NET-HUB	265
24.1	Mechanical Installation	265
24.2	Electrical Installation.....	267
25	Panel-Mount USB Port	268
25.1	Mechanical Installation	268
25.2	Electrical Installation.....	269
26	Standby Flight Display	270

27	Display Operation	271
27.1	Function Control	271
27.2	Screen Synchronization	276
27.3	Display Operation Procedures	277
27.4	In Flight Setup Menu	279
27.5	Software Updates and File Operations	287
28	Navigation Mapping Setup	291
28.1	Features Overview	291
28.2	Databases	291
29	Appendix A: Maintenance and Troubleshooting	299
29.1	Cleaning a SkyView Display	299
29.2	Saving a Screenshot of a Specific Screen	300
29.3	Savings a Settings File (Configuration of your SkyView system)	300
29.4	Saving a Dynon Diagnostic File	300
29.5	SkyView Displays Error: SYS EVENT 5: SEE SETUP	301
29.6	Returning SkyView Components to Service after Repair	302
29.7	Multi-display SkyView System, Continuing to Fly with a Missing Display	304
29.8	Operational Status	306
29.9	Instructions for Continued Airworthiness	308
29.10	Troubleshooting	308
30	Appendix B: Specifications	312
30.1	Minor Unit Physical Specifications	312
30.2	SkyView Compatible Engine Sensors (sold by Dynon Avionics)	313
30.3	SV-BAT-320 Specifications	314
30.4	SV-XPNDR-261 Specifications	315
30.5	SV-XPNDR-261 ADS-B Information	316
30.6	ADS-B Parameters Supported	316
30.7	SV-COM-T25 Specifications	318
30.8	SV-COM-T8 Specifications	319
30.9	SV-COM-T25/T8 Environmental Qualification Form	320
30.10	SV-GPS-2020 Specifications	321
30.11	SV-AP-TRIMAMP Specifications	322
31	Appendix C: Wiring and Electrical Connections	323
31.1	Wire Gauge	323
31.2	Grounding	323
31.3	DSUB Crimp Contacts and Tools	324
31.4	Non-Dynon Avionics Wire Harness Considerations	324
31.5	SkyView Equipment Electrical Connections	326
31.6	SkyView Equipment Electrical Connector Pinout Tables	327
32	Appendix D: SV-EMS-220 Sensor Input Mapping Worksheet	342
33	Appendix E: Serial Data Output	344
33.1	DYNON ADAHRS Serial Data Format	345
33.2	DYNON SYSTEM Serial Data Format	346
33.3	DYNON EMS Serial Data Format	349
33.4	DYNON ADAHRS / SYSTEM / EMS Serial Data Output Combinations	353
33.5	NMEA OUT Serial Data Formats	354
34	Appendix F: User Data Logs	355

34.1	User Data Log	355
34.2	Recent Flight Data Log.....	356
34.3	Alert Data Log.....	356
34.4	History Data Log	357
34.5	Data Logging Recording Options	357
35	Appendix G: Sensor Debug Data	359
36	Appendix H: Checklists	363
36.1	Saving Your Checklist with "UTF-8 Character Encoding"	364
36.2	Example Checklist	366
36.3	Example Checklist Formatting Notes:	367
36.4	Excel Checklist Generation Tool	368
36.5	Loading a Checklist	369
36.6	Displaying Your Checklist on your SkyView Display.....	371
37	Appendix I: Switches, Controls, Etc. External to SkyView Units	374

1 Introduction

This manual covers the mechanical, electrical, and pneumatic installation and configuration of the SkyView HDX system. The information in this manual is general to all airplanes on the Approved Model List (AML) of Supplemental Type Certificate (STC) SA02594SE.

Airplane-specific information, such as the installation of Autopilot servos, is provided in supplemental manuals. Supplemental manuals for a variety of airplanes are available in Dynon Avionics' certified manual repository: dynoncertified.com/docs.

Not all SkyView HDX functionality is approved for all airplanes. The AML specifies what functionality is approved for specific airplane makes and models. Although the information in this manual is comprehensive, it is the installer's responsibility to conform to industry standards and regulations, as applicable.

1.1 Product Delivery and Warranty

Upon delivery, visually inspect all SkyView HDX components, mounting trays and brackets, fasteners, cable harnesses, and accessories for damage that may have occurred during shipping. If damage has occurred, contact Dynon Technical Support.

Disassembled or modified modules may not be eligible for repair under warranty. Additionally, once a module has been disassembled, it is not considered airworthy and must be serviced at the factory. SkyView HDX System modules do not contain any field-serviceable parts like fuses, so there is no reason to disassemble any module.

1.2 Product Registration

Register the SkyView HDX system and components at dynoncertified.com/register. Product registration ownership, expedites warranty claims, and allows Dynon Avionics to send notification when product Service Bulletins and Technical Advisories are published. This site also allows owners and installers to register to receive news and product announcements from Dynon Avionics. Dynon Avionics will not share contact information with third-parties or send announcements without explicit consent.

1.3 Using this Manual

To reduce paper, Dynon Avionics does not provide a printed version of this manual. However, Dynon Avionics grants permission to third parties to print this manual, as necessary. The most recent PDF version is available for download at dynoncertified.com/docs. This manual is updated periodically, and it is important to use the most recent version when installing SkyView HDX components.

Dynon Avionics suggests keeping a PDF version of the manual on a smartphone, tablet, or laptop computer while installing SkyView HDX. Using the manual electronically allows quick navigation of the document, figures to be viewed in color, and keyword searches.

1.4 Manual Iconography

This manual uses the following iconography:



Alerts reader to important information.



Alerts reader to information regarding FAA compliance.



Alerts reader to helpful tips or suggestions.

1.5 Mechanical Drawings

All mechanical included in this manual are for *reference purposes only*. They should not be scaled or copied and used as templates or patterns.

1.6 Terminology

The terminology defined in [Table 1](#) is used throughout this manual.

Table 1: Definitions of Terms used in Manual

TERM	USAGE	DEFINITION / NOTES
Primary Flight Information	PFI	<ul style="list-style-type: none"> Includes attitude, altitude, airspeed, and magnetic heading information. Normally provided by SkyView HDX display units.
Primary Flight Information System	PFI System	<ul style="list-style-type: none"> System and components that provide PFI.
Primary Flight Display	PFD	<ul style="list-style-type: none"> PFI portion on the screen of a SkyView HDX display unit. PFD also describes the format of the PFI. The following outlines a standard PFD format: <ul style="list-style-type: none"> Attitude indicator located in top center, HSI located in bottom center, Airspeed Vertical Tape Indicator located right of center, Altitude Vertical Tape Indicator located right of center, Vertical Speed Indicator located right of Altitude indicator.

TERM	USAGE	DEFINITION / NOTES
Primary Display	Primary Display	<ul style="list-style-type: none"> • A role assigned to a SkyView HDX display unit. • Display unit must be installed in the Pilot's position and always present PFI during normal operation. • Can present other information in addition to PFI. • There must be one (and only one) Primary Display in a SkyView HDX system.
Secondary Display	Secondary Display	<ul style="list-style-type: none"> • A role assigned to a SkyView HDX display unit. • Display unit can be installed in any position other than the Pilot's position and present any flight/aircraft information during normal operation without restrictions. • Provides Backup PFI to the pilot if the Primary Display fails. • Up to two Secondary Displays can be installed in a SkyView HDX system.
Backup Primary Flight Information	Backup PFI	<ul style="list-style-type: none"> • If the Primary Display fails, the Secondary Display (if installed) provides PFI to the pilot.
Standby Flight Display	Standby Flight Display	<ul style="list-style-type: none"> • Provides redundant PFI from a dedicate display screen, ADAHRS, and 45-minute backup battery. • Allows the pilot to check integrity of PFI generated by the ADAHRS in SkyView HDX system and the Standby Flight Information System by cross-comparing them during normal operations.
Air Data, Attitude, and Heading Reference System	ADAHRS	<ul style="list-style-type: none"> • System that processes changes in air pressure, gyroscopic inertia, and magnetic heading over time to generate the PFI.
Navigation System	Navigation, NAV	<ul style="list-style-type: none"> • System and its components that provides Navigation information. • Navigation information portion on the screen of a SkyView HDX display unit. • Presents a moving map referred to as the Map.
Engine Monitoring System	EMS	<ul style="list-style-type: none"> • System and its components that provides engine and other airplane information. • Engine and airplane information portion on the screen of a SkyView HDX display unit.

1.7 Reference Documents

The following documents support the information in this document:

- 103014-000 Skyview HDX System Functional Overview
- 103221-000 SkyView HDX General Maintenance Manual
- 103272-000 SkyView HDX Airplane Flight Manual Supplement
- 103488-000 SkyView HDX System Wiring Diagram - Single Engine
- 103947-000 SkyView HDX System Wiring Diagram - Twin Engine
- 104003-000 D30 Installation and Maintenance Manual
- 103914-000 EFIS-D10A Installation and Maintenance Manual
- 104215-000 SkyView Third Party Connection and Configuration Reference
- AC 43.13-1B Acceptable Methods, Techniques and Practices - Aircraft Inspection and Repair
- AC 43.13-2B Acceptable Methods, Techniques and Practices - Aircraft Alterations

2 Important Information

This section contains important installation information that installers should read and understand before installing a SkyView HDX system into an airplane.

2.1 STC Approval

The Dynon Avionics STC approval for installing SkyView HDX system on airplanes listed on the associated Airplane Model List (AML), has no stated limitations. Therefore, the SkyView HDX system functions have been authorized to replace the similar functions that may have already existed in your airplane. Examples are:

- The replacement of the mechanical or electrical engine instruments with the SkyView HDX Engine Monitoring System (EMS).
- The replacement of vacuum and/or electric gyroscopic instruments such as the Directional Gyro or Attitude Gyro with the SkyView HDX ADAHRS module (SV-ADAHRS-200). By extension, when all vacuum instruments have been removed from the airplane, the vacuum system source may be removed as well.
- The SkyView HDX HSI is functionally equivalent to a TSO External HSI and is certified for IFR operations. TSO third party navigation equipment can be connected to the SkyView HDX HSI and operated under IFR. A separate HSI is not required by this STC for IFR flight operations.

2.2 Third-Party Products

The SkyView HDX system can connect to products not manufactured or provided by Dynon Avionics, such as FAA/TSO NAV radios, GPS receivers, and GPS Navigators. When connecting to third-party products, refer to Dynon Avionics' instructions as well as product manufacturer instructions to ensure the components are configured and wired for compatibility with the SkyView HDX system. If connection instructions for a product is not available from Dynon Avionics, contact Dynon Avionics Technical Support.

2.3 Installation Compliance

Airplanes on the AML meet a minimum required configuration for applicability of the STC. However, some airplanes may have been modified, and consequently, it may be difficult to use the information in this manual to completely substantiate the installation in compliance with the STC. It is the installer's responsibility to make the final determination of applicability for each individual airplane.

Prior to completing the installation, and before returning the aircraft to service, the installer must complete and submit a completed FAA Form 337 Major Repair & Alteration (Airframe, Powerplant, Propeller, or Appliance) to the appropriate FAA Aircraft Registration Branch. The form must include the following:

- Description of the SkyView installation.
- Description of how the SkyView interfaces with existing equipment and systems.
- Appropriately approved or acceptable data that demonstrates compliance.

Refer to AC 43.9-1G - Instructions for Completion of FAA Form 337 for additional information.

2.4 Pre-installation Information

Read and understand the following before proceeding with installation activities.



Always install avionics equipment in compliance with regulatory requirements found in Part 23 - Airworthiness Standards: Normal Category Airplanes, Subpart G - Flightcrew Interface And Other Information.

Always install avionics equipment in accordance with the guidance and approved engineering methods outlined the following FAA documents:



- 23.1311-1C - Installation of Electronic Display in Part 23 Airplanes
- AC 43.13-1B - Acceptable Methods, Techniques, and Practices - Aircraft Inspection
- AC 43.13-2B - Acceptable Methods, Techniques, and Practices - Aircraft Alterations



The appropriately-rated technician who will authorize the airplane's return to service should agree with the installation plan (i.e., methods, unit location, wire harness routing, etc.) before installation activities begin. This will help avoid potential rework should any part of the installation be found non-compliant.



The SkyView HDX ADAHRS module must be mounted rigidly to the airframe. If mounting the ADAHRS module to an avionics tray that mounts to the instrument panel, do not attach the instrument panel to the airframe with rubber mounts.

2.5 Installation Record

The technician performing the installation should record where each SkyView HDX component has been installed in the airplane. This documentation should then be entered into airplane's permanent record.

Dynon provides a document template to record this information. Download the *SkyView HDX Equipment Installation Record* document at dynoncertified.com/docs.

3 System Overview

SkyView HDX is an integrated Electronic Flight Instrument System (EFIS) that can aggregate flight, engine, navigation, traffic, and weather information for presentation to the pilot on a SkyView HDX display unit.

A SkyView HDX display unit is the central component of SkyView HDX system. Display units are multi-functional, high-definition, LCD color displays that process data inputs to generate graphical representations of aircraft instrumentation and indicators. SkyView HDX display units can also present a Map and Engine Monitoring information. Additionally, they generate messages and aural annunciations to alert pilots to exceptional flight and aircraft conditions.

Up to three SkyView HDX display units can be included in a SkyView HDX installation. A single SkyView HDX display unit can provide all system functionality and present all information associated with the Major and Ancillary systems. (See Section 3.1 for more information about Major and Ancillary SkyView HDX systems). At least one display unit is required for installation of a Major system.

Certain installation requirements must be met to ensure regulatory-compliant Primary Flight Information (PFI) presentation. Per STC SA02594SE, a Skyview HDX installation with PFI must also have a Standby Flight Display. This system must be separate and operate independently from SkyView HDX.



Per STC SA02594SE, a Skyview HDX installation with PFI must have a Standby Flight Display. Currently the Dynon EFIS-D10A and the Dynon D30 are the Standby Flight Displays certified for use with SkyView HDX.

The Standby Display must be installed in the instrument panel near the pilot's SkyView HDX display unit. This allows the pilot to cross-compare the PFI to ensure data integrity. In case of a SkyView HDX system failure, the pilot can immediately switch their focus from the SkyView HDX display unit to the Standby Flight Display.

3.1 Integrated System

Skyview HDX is an "integrated" system that can incorporate up to three Major systems and up to six Ancillary systems (see Table 2 for a list of Major and Ancillary SkyView HDX systems and their required and optional components). SkyView HDX systems provide a wide array of flight functions and airplane information to the pilot and are installed per need and preference.



For detailed information about the functions associated with each Major and Ancillary systems, refer the *SkyView HDX Functional Overview* document at dynoncertified.com/docs.

Table 2: Major and Ancillary SkyView HDX Systems

NAME	DESCRIPTION	COMPONENTS
MAJOR SYSTEMS		
Primary Flight Information System (PFI System) <i>Minimum System Installation per STC SA02594SE.</i>	Replaces the analog flight instruments that have traditionally provided PFI.	<i>Required:</i> <ul style="list-style-type: none"> • SV-HDX800 or SV-HDX1100 display unit (at least 1) • SV-BAT-320 backup battery (1 per display) • Standby Flight Display (1) • SV-ADAHRS-200 ADAHRS module (1) • SV-MAG-236 remote magnetometer (1) • Outside Air Temperature (OAT) sensor (1) • SV-GPS-2020 WAAS GPS antenna/receiver (1)
Navigation System	Provides a Map display, flight planning functions, and navigational course guidance plotting using FAA Obstacle, Terrain, and Airport Information databases and GPS-derived airplane position data. Requires the PFI System.	<i>Required:</i> <ul style="list-style-type: none"> • SV-HDX800 or SV-HDX1100 display unit (at least 1) • SV-BAT-320 backup battery (1 per display) • SV-ADAHRS-200 ADAHRS module (1) • SV-MAG-236 remote magnetometer (1) • Outside Air Temperature (OAT) sensor (1) • SV-GPS-2020 WAAS GPS antenna/receiver (1)
Engine Monitoring System (EMS)	Replaces a variety of engine and airplane instrumentation including engine instruments, fuel system instruments, flaps and landing gear position indicators, and fuel/time/distance computations	<i>Required:</i> <ul style="list-style-type: none"> • SV-HDX800 or SV-HDX1100 Display (at least 1) • SV-EMS-200 EMS module (at least 1) • Required and optional sensors vary by airplane model
ANCILLARY SYSTEMS		
Autopilot System	Provides two- or three-axes Autopilot (AP) control, depending upon what functionality has been certified for the airplane. Requires the PFI System. The Autopilot System is not available for all airplanes.	<i>Required:</i> <ul style="list-style-type: none"> • Pitch Servo (1) per airplane specification • Roll Servo (1) per airplane specification • SV-BUTTON-APDISC or Yoke-Mount Autopilot Disconnect Switch (at least 1) • SV-LEVEL-BUTTON Autopilot Level Button (1) (required if optional SV-AP-PANEL is not installed) <i>Optional:</i> <ul style="list-style-type: none"> • SV-AP-PANEL Autopilot Control Panel • SV-KNOB-PANEL Knob Control Panel • Yaw Servo (1) per airplane specification • SV-AP-TRIMAMP Trim Motor Adapter module (1) per airplane specification

NAME	DESCRIPTION	COMPONENTS
Communication System	<p>Provides 118.000 MHz to 136.992 MHz frequency information and tuning on the SkyView HDX display.</p> <p>Requires the PFI System or EMS.</p>	<p><i>Required:</i></p> <ul style="list-style-type: none"> SV-COM-T25 or SV-COM-T8 COM Transceiver (at least 1) SV-COM-PANEL COM Control Panel (1 per transceiver)
Transponder System	<p>Provides Mode-S transponder functionality. Also receives TIS-B (U.S. only) information.</p> <p>Requires the PFI System.</p>	<p><i>Required:</i></p> <ul style="list-style-type: none"> SV-XPNDR-261 Transponder (1)
IFR Navigation Integration System	<p>Allows SkyView HDX to interface with TSO IFR GPS Navigators.</p> <p>Requires the PFI System and Navigation System</p>	<p><i>Required:</i></p> <ul style="list-style-type: none"> SV-ARINC-429 Interface module (up to 2) Third-Party TSO IFR GPS Navigator device (at least 1)
Traffic and Weather Information System	<p>Receives ADS-B traffic and weather information via 978 MHz (UAT) and 1090 MHz. System presents traffic information on the PFD and traffic and weather on the Map.</p> <p>Requires the PFI System.</p>	<p><i>Required:</i></p> <ul style="list-style-type: none"> SV-ADSB-472 module (1)
Angle of Attack (AoA) Indicating System	<p>Provides aural tones as the critical AoA approaches.</p> <p>Requires the PFI System.</p>	<p><i>Required:</i></p> <ul style="list-style-type: none"> AoA probe and plumbing

See Figure 1 and Figure 2 for an overview of the data connections between components in an integrated SkyView HDX system.

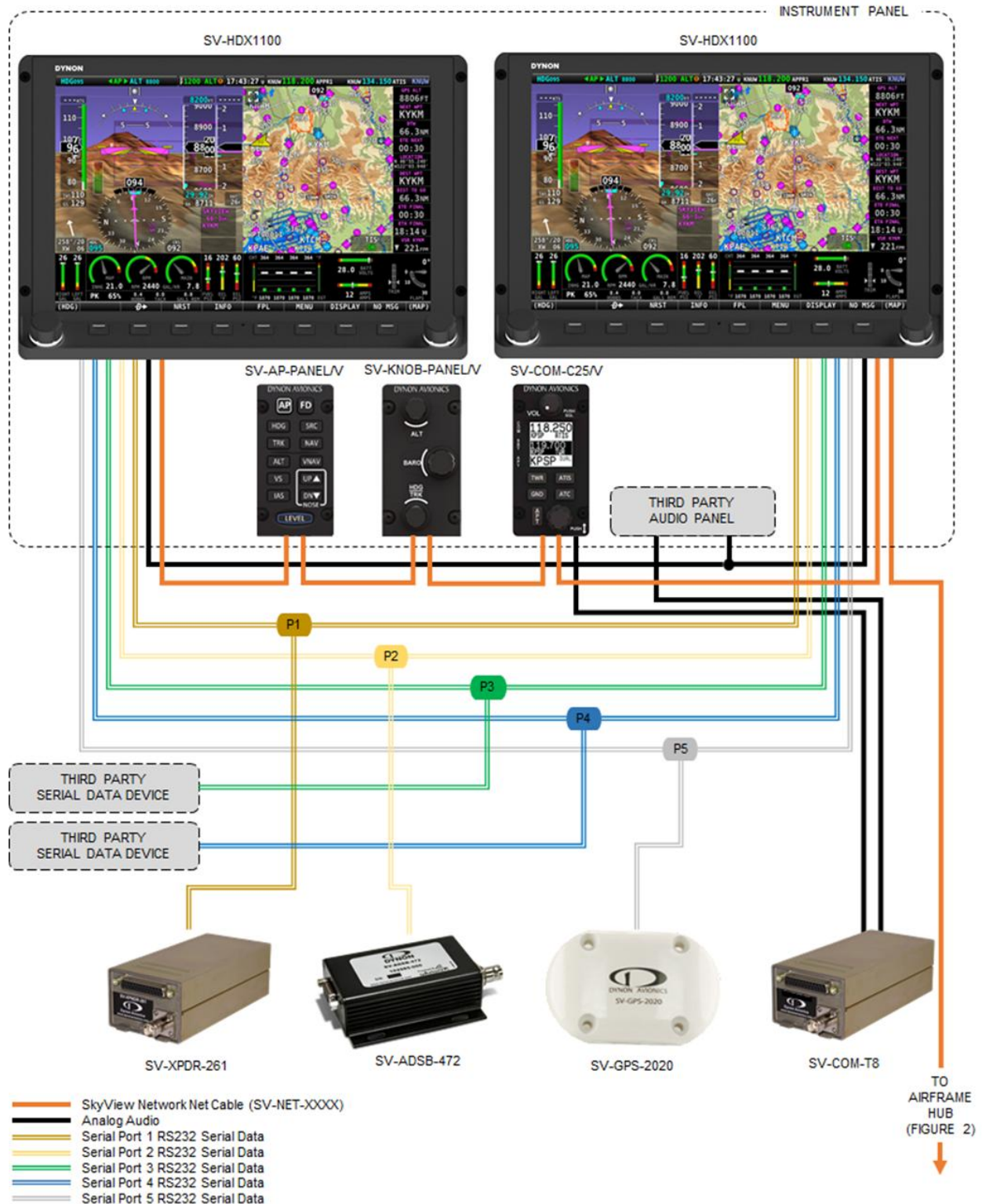

Figure 1: Typical SkyView HDX System Data Communications

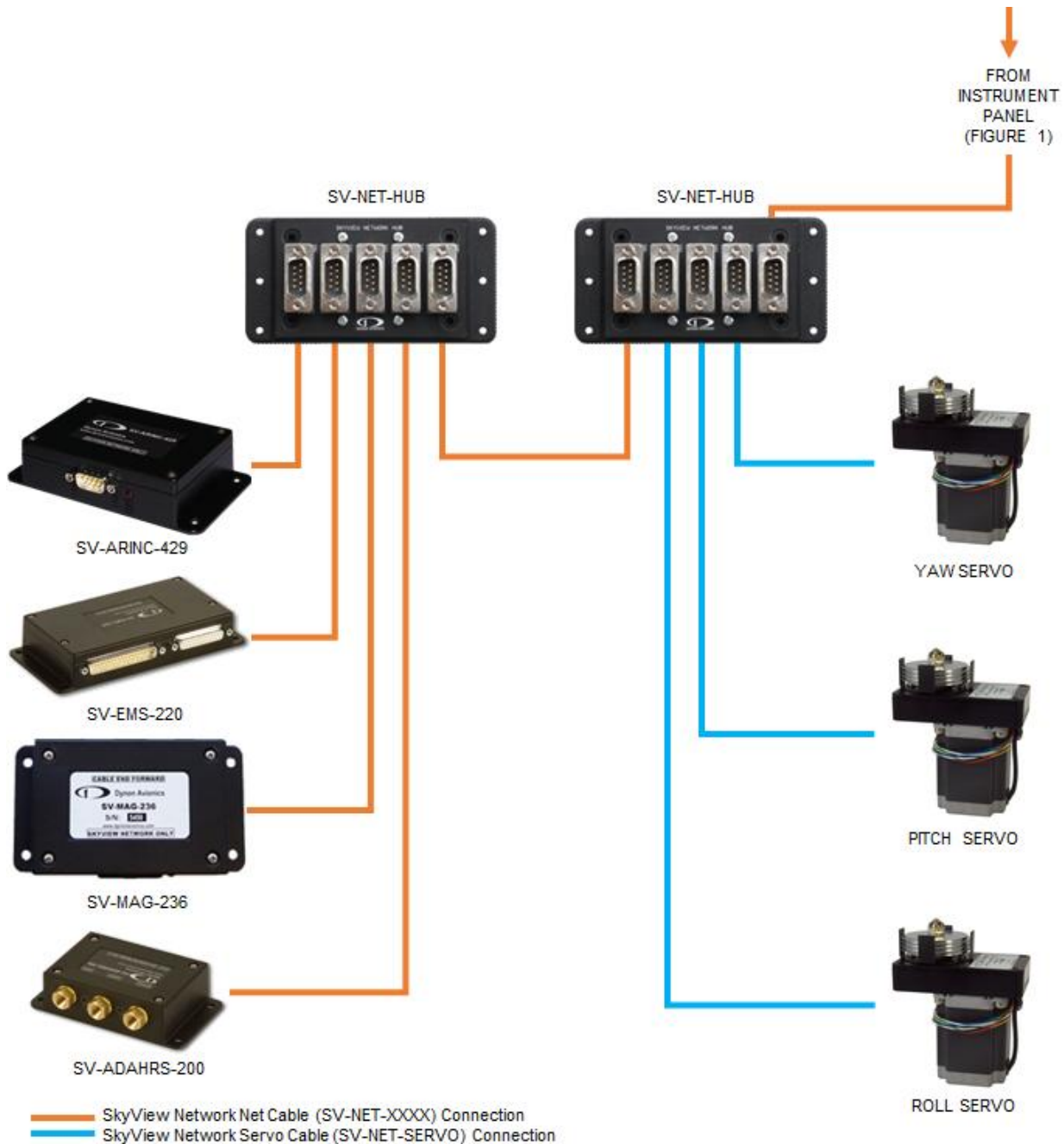

Figure 2: Typical SkyView HDX System Data Communications

See the *SkyView HDX System Wiring Diagram - Single Engine* and *SkyView HDX System Wiring Diagram - Twin Engine* documents at dynoncertified.com/docs for an overview of the electrical connections between components in an integrated SkyView HDX system, including the electrical connections between the Engine Monitoring System (EMS) module and the engine, fuel system, and other airplane inputs and indicators.

3.2 SkyView Network

The SkyView Network is a multi-drop (i.e., serial bus) network. Wiring is electrically common between all SkyView Network components. Network connections are made with unique network cables, hubs, splitters, and connectors on SkyView components. See Table 3 for a list of available network cables, splitters, and hubs.

3.2.1 Connectors

All SkyView Network cables, hubs, splitters, and devices have unique D9 connectors. These connectors look like RS-232 serial connectors; however, the pin allocation is unique to the SkyView HDX Network.



SkyView Network connectors *ARE NOT* interchangeable with RS-232 serial connectors. Equipment damage may result if a SkyView Network connector is connected to an RS-232 serial device, or an RS-232 serial connector is connected to a SkyView HDX display unit.

3.2.2 Connection Methods

There are two connection methods for setting up the SkyView Network: point-to-point and hub-and-spoke. Both methods may be used within the same installation.

Point-to-point is commonly used to connect SkyView control panels together on the instrument panel. This method is ideal for connecting control panels because they have two D9 connectors. In a point-to-point connection, a network cable can have one end connected to a SkyView HDX display unit and the other end connected to a control panel. Then, a second network cable can have one end connected to the second port in the same control panel and the other end connected to a second control panel. This connection method can continue until all control panels on the instrument panel mounted are interconnected with network cables. See Figure 1 for an example of the point-to-point connection method.

Hub-and-spoke is commonly used to connect network devices (except control panels) to the SkyView Network. The hub-and-spoke method is ideal for connecting SkyView components because they only have one D9 connector. In a hub-and-spoke connection, a central hub connects a SkyView HDX display unit to peripherally located network devices via SV-Network cables. See Figure 2 for an example of the hub-and-spoke connection method.

3.2.3 Hub and Splitter

The SV-NET-HUB Network Hub has five D9M connectors to connect display and network devices. The SV-NET-HUB is designed to ease device connection to the SkyView Network. Fewer overall connections are required, and SkyView Network expansion is easier with a network hub rather than a network splitter (SV-NET-SPL).

The SV-NET-SPL Network Splitter has one D9M connector and two D9F connectors. It is used to connect an additional network device to the SkyView Network in lieu of a network hub. A network hub (SV-NET-HUB) is recommended for connecting multiple modules to the SkyView Network.

3.3 Other System Connections

3.3.1 Serial Connection

Third-party devices and some SkyView components communicate with the display units via serial connection. There are designated pins/wires on the SV-HARNESS-D37 for serial port connection. Data received via serial connection is not automatically shared between multiple SkyView HDX display units; therefore, serial devices must be electrically connected to each installed SkyView HDX display unit. This ensures continued data communication in the event of a SkyView HDX display unit failure.

For serial data communication, the TX terminal of the transmitting device's serial port must be connected to the RX terminal of the receiving device's serial port. It is the installer's responsibility to determine how to connect third-party serial devices to the displays. Installers should reference the manufacturer's documentation for serial connection specifications.

3.3.2 Ethernet Connection

Every SkyView HDX display unit has an RJ45 ethernet port. In SkyView HDX systems with dual display units, the display units should be connected via their ethernet port. Dynon Avionics offers a Low Smoke Zero Halogen (LSZH) ethernet cable (SV-ETHERNET-3CC) for this connection. This is not a required connection; however, it allows aviation and obstacle data to be transferred between connected display units. If the display units are not connected, aviation and obstacle databases will need to be loaded on each display individually.

3.3.3 USB Port Connection

There are two USB ports on the rear of a SkyView HDX display unit. These USB ports are used for transferring files (firmware backups/updates, software and database updates, configuration file uploads, and log file downloads) between a SkyView HDX display unit and a USB drive. The USB ports are extendable via the Panel-Mount USB Port to an instrument panel or other location in the airplane cabin.

3.4 Wire Harnesses & Network Cables

Dynon Avionics offers component wire harnesses and a wide-range of network cables to significantly simplify the electrical installation of a SkyView HDX system. See [Table 3](#) for a list of available wire harnesses and network cables. All wire harnesses and network cables (except the SV-NET-TEST) are made with aircraft-grade Tefzel® wiring.

Table 3: Available Wire Harnesses & Network Cables

CABLE / HARNESS	DESCRIPTION
SV-HARNESS-D37	Wire Harness for SV-HDX800 and SV-HDX1100 Displays – 6 ft. (1.83 m)
SV-HARNESS-XPNDR	Wire Harness for SV-XPNDR-261 Transponder – 15 ft. (4.57 m)
SV-HARNESS-ADSB	Wire harness for SV-ADSB-472 Module – 15 ft. (4.57 m)
Engine Sensor Main Wire Harness	Wire Harness for SV-EMS-220 Module – 6 ft. (1.83 m)
EGT/CHT Wire Harness, 4 Cyl.	EGT/CHT Wire Harness for SV-EMS-220 Module – 6 ft. (1.83 m)
EGT/CHT Wire Harness, 6 Cyl.	EGT/CHT Wire Harness for SV-EMS-220 Module – 6 ft. (1.83 m)
SV-NET-SERVO	SkyView Network Cable Kit for Autopilot Servos – 20 ft. (6.10 m) One (1) SV-NET-SERVO is used for each autopilot servo.
SV-NET-6inCC	SkyView Network Cable, both ends with connectors – 6 in (15.24 cm)
SV-NET-8inCC	SkyView Network Cable, both ends with connectors – 8 in (20.32 cm)
SV-NET-10inCC	SkyView Network Cable, both ends with connectors – 10 in (25.40 cm)
SV-NET-1CC	SkyView Network Cable, both ends with connectors – 1 ft. (0.30 m)
SV-NET-1.5CC	SkyView Network Cable, both ends with connectors – 1.5 ft. (0.46 m)
SV-NET-2CC	SkyView Network Cable, both ends with connectors – 2 ft. (0.61 m)
SV-NET-3CC	SkyView Network Cable, both ends with connectors – 3 ft. (0.91 m)
SV-NET-6CC	SkyView Network Cable, both ends with connectors – 6 ft. (1.83 m)
SV-NET-10CP	SkyView Network Cable, 1 end connector, 1 end pins only – 10 ft. (3.05 m)
SV-NET-15CP	SkyView Network Cable, 1 end connector, 1 end pins only – 15 ft. (4.57 m)
SV-NET-20CP	SkyView Network Cable, 1 end connector, 1 end pins only – 20 ft. (6.10 m)
SV-NET-25CP	SkyView Network Cable, 1 end connector, 1 end pins only – 25 ft. (7.62 m)
SV-NET-HUB	SkyView Network Hub (5 SkyView HDX Network connections) (Does not include a SkyView HDX Network cable)
SV-NET-SPL	SkyView Network Splitter – 1 ft. (30.5 cm)

* Network cables with CP suffix include an unattached second connector for routing through tight areas in an airplane.

3.5 Power Protection

All SkyView components have robust power protection. This allows power-up during engine start for full engine monitoring. SkyView HDX display units require a minimum of 10V DC. During engine start, it is common for the airplane's electrical system to temporarily drop below 10V DC. When this happens, SkyView HDX display units switch to the SV-BAT-320 backup battery, and then switch back when voltage input is above 10V DC.

3.6 Specifications

Table 4 contains SkyView displays and devices that are powered by SkyView displays. 5A circuit protection is recommended for SkyView displays in common configurations as 5A is the smallest circuit breaker that is commonly available in certified versions.

Table 4: Power Specifications for SkyView Displays and Devices Powered by SkyView Network

SkyView Displays: No SV-BAT-320 (see below) No SkyView Network modules No USB devices Display brightness at maximum	Current Req. @ 12V DC	Current Req. @ 24V DC	Circuit Protection Recommended
SV-HDX800 all S/N	2.10A	1.00A	5A
SV-HDX1100 all S/N	2.40A	1.20A	5A
Devices powered from SkyView Displays			
These devices are directly connected to an individual SkyView display and are powered by the display. Add the current consumption of these devices to the current consumption of the SkyView display they are connected to. This will allow you to calculate the total current that each SkyView display requires.			
SV-BAT-320 (while charging)	1.00A	0.50A	N/A
SV-GPS-2020	0.10A	0.05A	N/A
Video Adapter for SkyView (USB)	0.15A	0.08A	N/A
SkyView Wi-Fi Adapter (USB)	0.10A	0.05A	N/A
Devices powered via SkyView Network			
These devices are connected to SkyView Network, which is powered by the SkyView display(s). If you have two (2) or three (3) displays, the current requirements of these devices are shared equally between the displays. If you have one (1) display, add 100% of a SkyView Network device's current to the display's current requirement. If you have two (2) displays, add 50% of SkyView Network device's current to each display's current requirement. If you have three (3) displays, add 33% of SkyView Network device's current to each display's current requirement.			
SV-ADAHRS-200	0.15A	0.08A	N/A
SV-AP-PANEL (not including trim motor loads)	0.05A	0.03A	N/A
SV-ARINC-429	0.10A	0.05A	N/A
SV-EMS-220 (maximum number of sensors)	0.11A	0.06A	N/A
SV-KNOB-PANEL	0.07A	0.04A	N/A
SV-MAG-236	0.15A	0.08A	N/A

For example, an HDX1100 @ 12V with:

- 1 – SV-BAT-320 (1.00A),
- 1 – SV-GPS-2020 (0.10A),
- 1 – SV-ADAHRS-200 (0.15A), and
- 1 – SV-EMS-220 (0.11A),

Table 5 contains power specifications for SkyView units that are powered from aircraft power (not powered by the SkyView Network). The circuit protection recommendations are suitable for most installations and assume that you are using Dynon Avionics harnesses and/or are following the wiring advice in this Installation Manual. It may be possible to use different sized circuit protection if the protective device has suitable load overhead for the connected device(s). It is also important that circuit protection devices be appropriately sized to protect the *wiring* connected to them. 5A circuit protection is recommended in most cases because that is the smallest circuit breaker that is commonly available in certified versions, and Dynon Avionics wiring harnesses specify wire of at least 22 AWG.

Table 5: Power Specifications for SkyView Units Powered by Aircraft Power

Unit	Current Reqt. @ 12V DC	Current Reqt. @ 24V DC	Circuit Protection Recommendation
SV-ADSB-472	0.10A	0.05A	5A
SV-XPNDR-261	0.40A	0.20A	5A
Servos (All) – Not Engaged	0.13A	0.07A	5A
SV32 (all variants) Moving @ 100% torque	1.30A	0.70A	
SV42 (all variants) Moving @ 100% torque	2.00A	1.00A	
SV-AP-TRIMAMP	5.00A*	5.00A*	5A

*Maximum—may be less depending on trim motor requirements.

Table 6 contains physical specifications of major units. Note that dimensions listed in this table are approximate – see the installation sections of each unit for installation drawings with precise dimensions.

Table 6: SkyView System Component Physical Specifications

Unit	Dimensions	Weight
SV32	2.47" W x 4.20" H x 3.98" D (63mm W x 107mm H x 101mm D)	2.0 lb. (0.91 kg)
SV42	2.47" W x 5.13" H x 3.98" D (63mm W x 130mm H x 101mm D)	3.0 lb. (1.36 kg)
SV-ADAHRS-200	4.71" W x 1.22" H x 2.61" D (120mm W x 31mm H x 66mm D)	0.5 lb. (0.23 kg)
SV-ADSB-472	4.10" W x 0.97" H x 2.79" D (104.2mm W x 24.7mm H x 70.8 D)	0.3 lb. (0.13 kg)
SV-AP-PANEL	3.53" W x 1.80" H x 1.27" D (89.7mm W x 45.7mm H x 32.4mm D)	0.3 lb. (0.13 kg)
SV-ARINC-429	4.75" W x 1.09" H x 2.61" D (121mm W x 28mm H x 66mm D)	0.4 lb. (0.18 kg)
SV-COM-PANEL	3.53" W x 1.80" H x 1.27" D (89.7mm W x 45.7mm H x 32.4mm D)	0.4 lb. (0.18 kg)
SV-COM-T25/T8 (w/ mounting tray)	2.5" W x 1.9" H x 6.3" D (66mm W x 48mm H x 160mm D)	0.8 lb. (0.36 kg)
SV-BAT-320	3.30" W x 2.10" H x 3.90" D (84mm W x 53mm H x 99mm D)	0.8 lb. (0.36 kg)
SV-EMS-220	6.35" W x 1.09" H x 2.99" D (161mm W x 28mm H x 76mm D)	0.6 lb. (0.27 kg)
SV-GPS-2020	2.19" W x 0.75" H x 3.44" D (56mm W x 19mm H x 87mm D)	0.5 lb. (0.23 kg)
SV-HDX800	7.64" W x 5.59" H x 3.21" D (194mm W x 142mm H x 81.5mm D)	2.6 ±0.2 lb. (1.18 ±0.09 kg)
SV-HDX1100	10.31" W x 7.1" H x 3.1" D (262mm W x 179.5mm H x 79mm D)	3.3 ±0.2 lb. (1.50 ±0.09 kg)
SV-KNOB-PANEL	3.53" W x 1.80" H x 1.27" D (89.7mm W x 45.7mm H x 32.4mm D)	0.4 lb. (0.18 kg)
SV-MAG-236	4.71" W x 1.22" H x 2.61" D (120mm W x 31mm H x 66mm D) (not including cable - 18" (457mm))	0.5 lb. (0.23 kg)
SV-XPNDR-261 (w/mounting tray)	2.5" W x 1.9" H x 6.3" D (66mm W x 48mm H x 160mm D)	0.8 lb. (0.36 kg)
SV-AP-TRIMAMP	3.77" W x 1.18" H x 3.56" D (96mm W x 30mm H x 90mm D)	0.4 lb. (0.18 kg)

Table 7 contains environmental specifications for major SkyView units.

Table 7: SkyView System Component Environmental Specifications

Environmental Specifications	Storage Temperature	Operating Temperature
SV32 (various) SV42 (various)	-22° F to 167° F (-30° C to 75° C)	-22° F to 140° F (-30° C to 60° C)
SV-ADAHRS-200	-40° F to 158° F (-40° C to 70° C)	-22° F to 140° F (-30° C to 60° C)
SV-ADSB-472	-40° F to 158° F (-40° C to 70° C)	-22° F to 140° F (-30° C to +60° C)
SV-ARINC-429	-40° F to 158° F (-40° C to 70° C)	-22° F to 140° F (-30° C to +60° C)
SV-BAT-320	-4° F to 140° F (-20° C to 60° C)	-4° F to 140° F (-20° C to 60° C)
SV-HDX800 SV-HDX1100	-40° F to 158° F (-40° C to 70° C)	-22° F to 140° F (-30° C to 60° C)
SV-EMS-220	-40° F to 158° F (-40° C to 70° C)	-22° F to 140° F (-30° C to 60° C)
SV-GPS-2020	-40° F to 158° F (-40° C to 70° C)	-40° F to 140° F -40° C to 60° C
SV-KNOB-PANEL	-40° F to 158° F (-40° C to 70° C)	-22° F to 140° F (-30° C to 60° C)
SV-MAG-236	-40° F to 158° F (-40° C to 70° C)	-22° F to 140° F (-30° C to 60° C)
SV-XPNDR-261	-67° F to 185° F (-55° C to 85° C)	-4° F to 158° F (-20° C to 70° C)
SV-AP-TRIMAMP	-40° F to 158° F (-40° C to 70° C)	-22° F to 140° F (-30° C to +60° C)

3.7 Bench Test Quick Start

This section contains information that can be used to check out your SkyView system on the bench, or immediately after SkyView has been installed in the plane. This section is not a substitute for reading this entire manual, which provides instructions for wiring and configuring SkyView to the unique requirements of your airplane.

1. A SkyView display requires 10-30 VDC. You must connect BOTH of the (long) red wires to POWER and BOTH of the (long) black wires to Ground. Current for each display can be up to 3.5A @ 12V (add 1.5A if the SV-BAT-320 battery is connected and being charged); so, use a big battery or power supply.
2. To power on or power off a SkyView display manually, push, and hold Button #1 (the leftmost button).
3. Any devices connected to SkyView that do not receive their power from the SkyView Network (such as SV-XPNDR-261 and Dynon Avionics Autopilot servos) must also be powered ON to communicate with SkyView.

4. To finish the installation of the SV-NET-10CP (10 foot) and longer cables, the diagram you need to insert the pins is of the SkyView Network Pinout (SV-NET-XXXX) found in Section 31: *Appendix C: Wiring and Electrical Connections*.
5. The EMS 37-pin Main Sensor Harness includes a 9-pin connector that is wired to pins 11 (Orange wire), 12 (Yellow wire), and 30 (Black wire). This connector is used for other Dynon Avionics products but is not used in SkyView installations. Thus, the 9-pin connector should be removed to use these wires for connecting sensors to the SV-EMS-220. Remove the connector by cutting the three (3) wires close to the 9-pin connector.
6. The SkyView SETUP MENU is accessed by pushing and holding Buttons 7+8 together for 2-3 seconds.
7. Setting the Tail Number is required before you can configure your SkyView Network (described below): SETUP > AIRCRAFT INFORMATION > TAIL NUMBER. If the Tail Number has not yet been issued for your plane, set the TAIL NUMBER to something other than DYNON AVIONICS. Note that for US planes, the leading N is a required part of the TAIL NUMBER. The TAIL NUMBER should not include dashes (-) or spaces.

Examples:

Correct: N120AB

Incorrect: N-120AB, N12OAB, 120AB, or N 12AB

8. SkyView displays and modules communicate over a common set of wires – the SkyView Network that terminates at the D9 connectors on the back of your SkyView display(s). Getting all modules and displays "talking" on SkyView Network is done by going to SETUP MENU > SYSTEM SETUP > SKYVIEW NETWORK SETUP > CONFIGURE > (right click one (1) more time). If a module is noted as "requires update", press the UPDATE button. Otherwise, press the FINISH button. Note that you will not see any flight instruments or engine instruments before a network configuration is performed, even if the SV-ADAHRS-200/201 and SV-EMS-220 have been wired properly and are connected.
9. Devices that do not utilize the SkyView Network are connected via RS-232 serial port connections. Dynon Avionics devices that use RS-232 serial ports include the SV-ADSB-472, SV-GPS-2020, SV-XPNDR-261, and various third-party devices. As RS-232 serial devices are not part of the SkyView Network, they will not be seen on the list of devices seen as you configure the SkyView Network above. Instead, configuring SkyView to communicate with SV-GPS-2020 and SV-XPNDR-261 is done via a more manual process in SETUP MENU > SYSTEM SETUP > SERIAL PORT SETUP.
10. If you have installed an SV-GPS-2020, its SERIAL IN FUNCTION must be set to POS 1.
11. After you have configured the SkyView Network, and have properly configured any serial devices, exit SETUP MENU. Your SkyView display should now display EMS, PFD, and. Map will not display without a GPS fix (the airplane symbol on the Map page will also flash with "?" if it does not have a GPS fix).

-
12. Your SkyView System may require various updates, such as system Software, databases, and Sensor Definitions. See dynoncertified.com/docs for certified products for more details on the updates available for the SkyView HDX System.
 13. Common issues for setting up SkyView engine monitoring:
 - a. The configuration of sensors installed on SkyView at the factory is generic; therefore, "Red X's" on the EMS for various sensors are normal until sensor configuration for your engine sensor configuration is complete.
 - b. The layout of which sensor "widgets" are shown on the screen: sizes; styles; etc., is completely configurable: SETUP > EMS SETUP > SCREEN LAYOUT EDITOR.
 14. Common issues for setting up SV-XPNDR-261:
 - a. Ensure that a valid tail number has been set (see above).
 - b. Ensure that a valid HEX CODE has been set SETUP > TRANSPONDER SETUP > TRANSPONDER HEX CODE. A caution message – XPNDR HEX CODE NOT SET will appear if a transponder is configured in SkyView, but the HEX CODE is not set to a valid number.
 - c. Traffic will not be displayed unless you are in an area covered by an TIS radar site (US only).
 15. Common issues for setting up Dynon Avionics Autopilot:
 - a. Servos must be powered ON.
 - b. Servos must be recognized on the SkyView Network (above).
 - c. AIRSPEED LIMITATIONS must be set (at least one (1) must be actively adjusted from the defaults) before the Autopilot can be configured: SETUP > PFD SETUP > AIRSPEED.
 - d. AP SERVO CALIBRATION must be performed: SETUP > HARDWARE CALIBRATION > AP SERVO CALIBRATION > CALIBRATION.
 - e. After the AP SERVO CALIBRATION has successfully completed, the AP status will be displayed on the SkyView display top bar.

4 Instrument Panel Design

Installing SkyView HDX necessitates the design and fabrication of a new instrument panel to mount the SkyView panel-mounted equipment. This section provides quantified and qualified regulatory guidance, as well as volumetric requirements for the SkyView panel-mounted equipment to help you decide where to locate equipment on the instrument panel. Panel cut-out and mounting hole dimensions are provided for each component where applicable.



Installation or relocation of cockpit equipment and controls are not authorized by STC SA02594SE. Consult applicable manufacturer documentation or FAA guidance for aircraft modifications involving the installation or relocation of cockpit equipment and controls.



Installation of a SkyView HDX system must be completed by authorized individuals. Modifications to instrument panels must be completed and approved in a manner acceptable to the FAA. The design and installation instructions, information, and references in this manual are guidance and recommendations to the installer. For approval of instrument panel design, consult AC 43.13-2B Chapter 11, Section 1104 or a certified technician or inspector.

4.1 Regulatory Considerations

Part 23 of the Code of Federal Regulations describes locations for displaying information which, for the most part, is information presented on SkyView HDX Display screen. Exceptions to this are the information that may be presented in the COM control panel or a third-party GPS Navigator. All system information must be evaluated and considered when determining the best equipment locations for your instrument panel.



Before beginning a SkyView HDX system installation, it is highly recommended that the technician with Inspection Authority (IA) that is approving your airplane's return to service agrees with the proposed equipment location and installation methods, wire harness routing, and the location of mounted equipment on the instrument panel.

Doing so reduces the likelihood that the installation will not be found compliant with regulatory requirements and airworthy standards.



Refer to the guidance and approved engineering provided by the following FAA documents:

- AC 23.1311-1C - Installation of Electronic Display in Part 23 Airplanes
- AC 43.13-1B - Acceptable Methods, Techniques, and Practices - Aircraft Inspection
- AC 43.13-2B - Acceptable Methods, Techniques, and Practices - Aircraft Alterations

4.2 Instrument Panel Material Requirements

To maintain structural integrity of the aluminum instrument panel, make sure the instrument panel design incorporates a minimum 3/4" (0.75") edge margin around the perimeter of all cutouts for SkyView HDX displays. Additionally, design all replacement instrument panels in accordance with the guidance for sheet metal thickness in Table 8.

Specification approved aluminum alloys include, but may not be limited to, the following:

- 6061-T6 QQ-A-250/11 BARE
- 2024-T3 QQ-A-250/5A ALCLAD
- 2024-T3 QQ-A-250/4 BARE
- 7075-T6 QQ-A-250/13 ALCLAD
- 7075-T6 QQ-A-250/12 BARE

For instrument panels made of other materials, or instrument panels with significant loadbearing function, consult the instructions for continued airworthiness (ICA) provided by the aircraft manufacturer. If no appropriate guidance exists, consult applicable FAA guidance such as AC 43.13, or an FAA designated engineering representative (DER).



If replacing an existing instrument panel, the best practice and method is to reuse existing instrument panel supports and/or stiffeners.

When modifying or fabricating instrument panels, use the same or higher specification fasteners and support/stiffener materials used by the aircraft manufacturer.

Table 8: Instrument Panel Sheet Metal Thickness Guidance

Original Panel Material Thickness	Replacement Panel Material Thickness
1/8" (0.125") or more	Replace with same
7/64" (0.100")	1/8" (0.125")
3/32" (0.090")	7/64" (0.100")
5/64" (0.080")	3/32" (0.090")
1/16" (0.063")	5/64" (0.080")
Less than 1/16" (0.063")	1/16" (0.063")



Include paint, finish, and overlay when measuring the original instrument panel material thickness.

4.3 Primary Flight Information

The FAA defines the Attitude, Altimeter, Airspeed, and the Heading information (shown arranged in the traditional analog T-layout in Figure 3) as the Primary Flight Information (PFI). In SkyView HDX display, the PFI appears in the part of the display called the Primary Flight Display (PFD).



Figure 3: Analog Primary Flight Information (PFI) arranged in the T-Layout

4.3.1 Quantitative Considerations

The quantitative requirements for displaying of information, as described in *AC 23.1311-1C Section 15.0 Pilot Field-of-View Considerations*, must be met to comply with §23.2600 Flightcrew Interface (a)(b).

The placement of information within the area of the instrument panel defined as the Primary Field-of-View, and Maximum Field-of-View, reduces the potential for spatial disorientation due to movement of the pilot's head to see the information needed to fly the airplane is minimized.

If your airplane does not have a published design eye reference point, one could be developed using the "95th percentile human" as a size model seated in the pilot's position of your airplane. From this eye reference position, you will be able to determine the Primary Field-of-View and Primary Maximum Field-of-View.

4.3.2 Primary Field-of-View

AC 23.1311-1C describes the normal line-of-sight as the vertical and horizontal visual fields from the design eye reference point that can be accommodated *with eye movement only*.

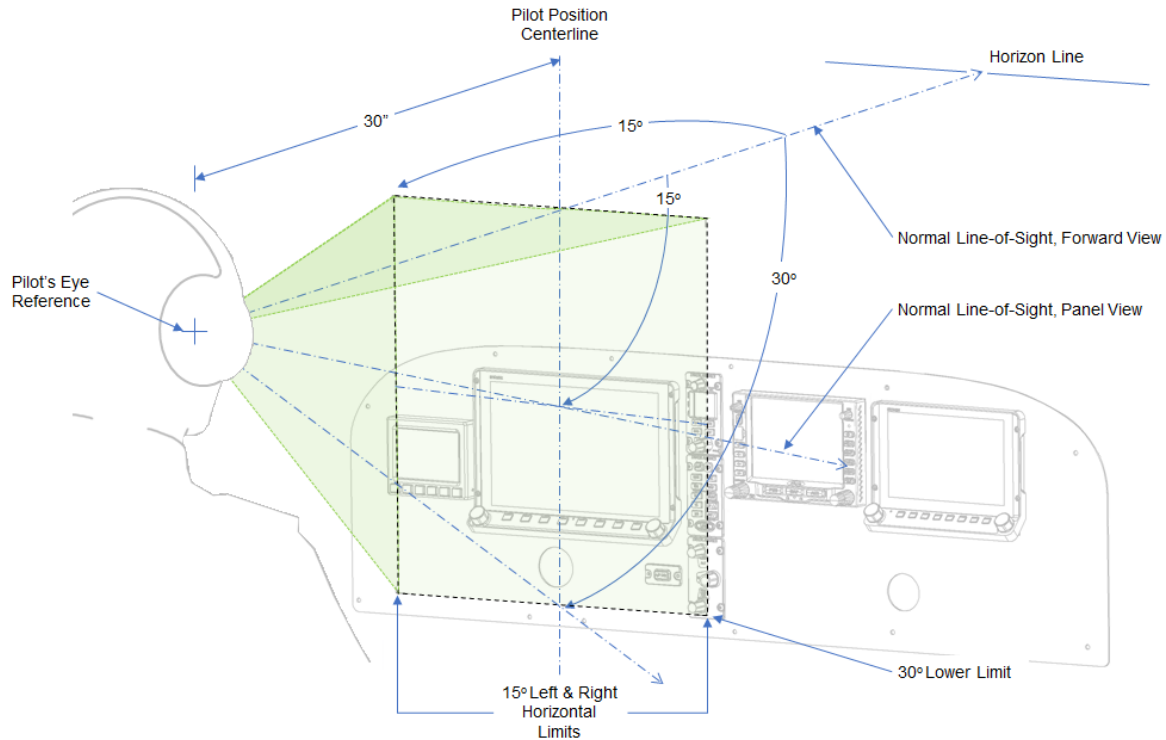

Figure 4: Primary Field-of-View

When geometry is applied to an instrument panel located 30 inches from the eye reference point identified in AC 23.1311-1C Section 15.4 Table 3, the resulting horizontal boundary dimension of the primary maximum field-of-view is 8.00 inches on either side of the pilot's position centerline reference, as shown in Figure 5.

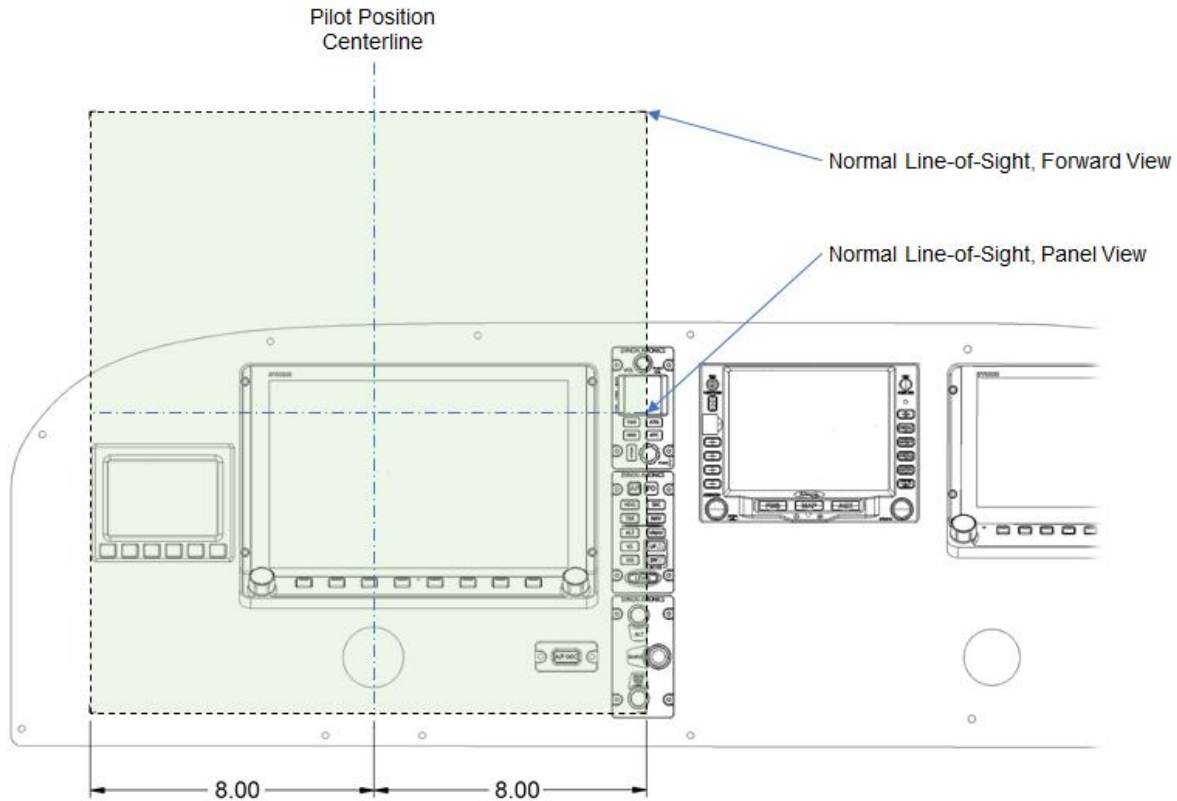

Figure 5: Primary Field-of-View Horizontal Boundary Dimensions

All primary flight information (as defined in Section 3.1) needs to be located within the horizontal boundaries of the Primary Field-of-View. The SkyView HDX PFD can be configured by the pilot to be 100% of the entire display, or it can be reduced to 50% of the display's width. When considering where to place the HDX display in the instrument panel, consider that only the 50% width of the display configured as the PFD must be located within the primary field-of-view. Doing so may allow more of the Standby Display to fit within the primary field-of-view horizontal boundaries.

According to the AC 23.1311-1C, standby instruments shall be placed "*as close as practicable*" to the PFI. This translates into locating the standby display close to the primary display in a position that will cause the least amount of pilot fatigue during use.

Because a designed pilot's eye reference point may not have been described by your airplane manufacturer, and you are retrofitting within the constraints of an existing aircraft, it is mandatory that you place the Primary Flight Information:

- Horizontally within the boundaries of the Primary Field-of-View.
- Vertically as high in the instrument panel as practical while avoiding any visual occlusion from potential obstructions such as the glareshield.

As demonstrated in Figure 5, the SkyView HDX display, and the standby display can comfortably fit within the calculated boundaries of the Primary Field-of-View as they are defined by AC 23.1311-1C Section 15.4 Table 3.

4.3.3 Primary Maximum Field-of-View

According to AC 23.1311-1C, the Primary Maximum Field-of-View is based on the vertical and horizontal visual fields from the design eye reference point that can be accommodated *with eye movement and minimal head movement*.

The vertical primary maximum field-of-view limit is defined by the FAA as 30 degrees below the normal line-of-sight forward view line. The horizontal primary field-of-view is defined by the FAA as 35 degrees left and right of the horizontal eye reference point (see Figure 6).

The area of the instrument panel defined by the above parameters represents the area normally used for important and frequently used information. Ideally, the optional SkyView HDX control panels will be located within the primary maximum field-of-view, as will any third-party equipment such as an GPS IFR navigator. An example of primary maximum field-of-view as it applies to a typical instrument panel located at the AC 23.1311-1C prescribed position of 30 inches from the pilot's eye reference position can be seen in Figure 6.

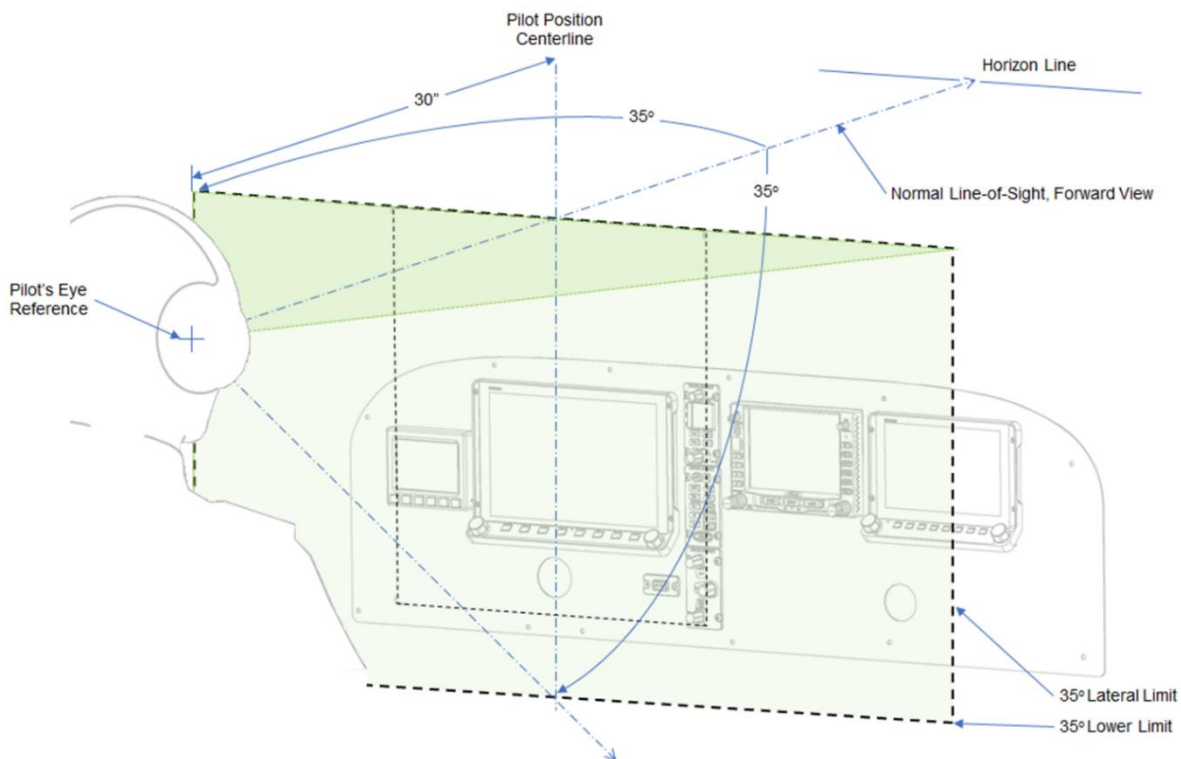

Figure 6: Primary Maximum Field-of-View

When geometry is applied to an instrument panel located at the 30 inches from the eye reference point identified in AC 23.1311-1C Section 15.4 Table 3, the resulting horizontal boundary dimension of the primary maximum field-of-view is 21.0 inches on either side of the pilot's position centerline reference, as shown in Figure 7.

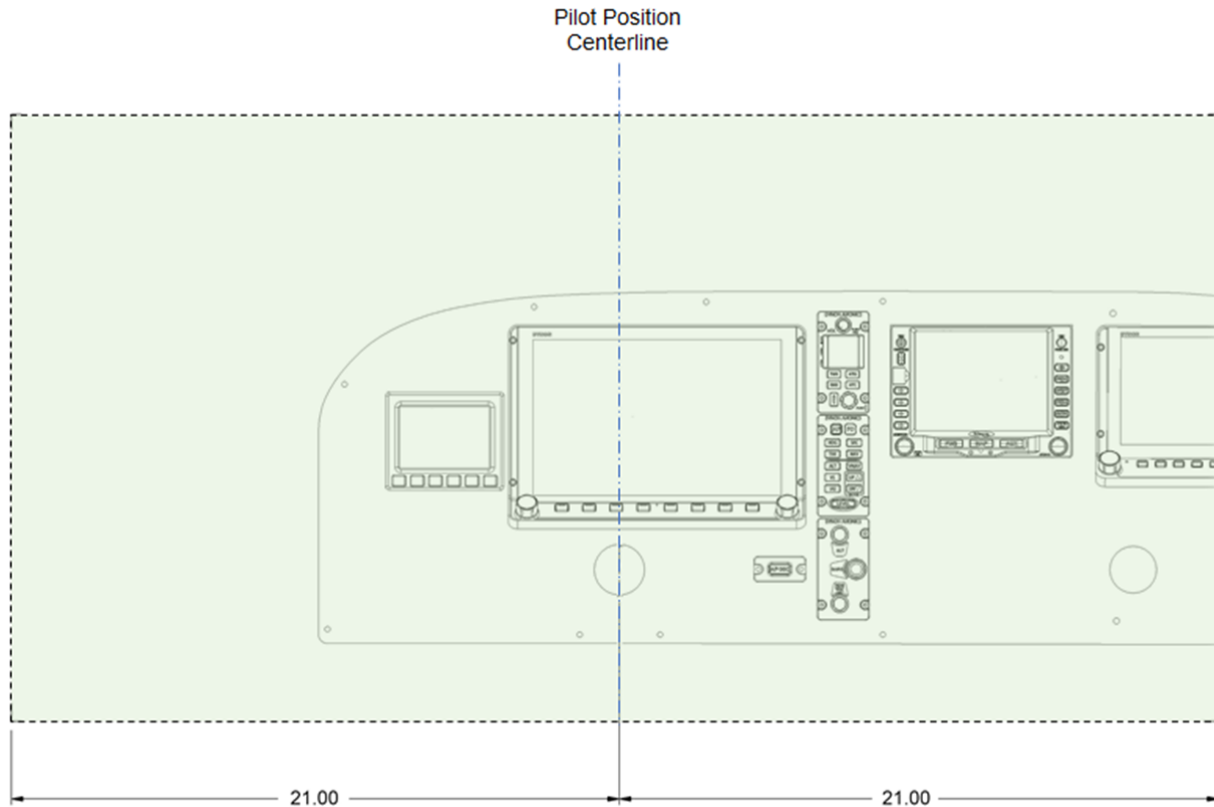

Figure 7: Primary Maximum Field-of-View Horizontal Boundary Dimensions

As demonstrated in Figure 7, the SkyView panel-mounted equipment, as well as many other panel-mounted equipment can comfortably fit within the calculated boundaries of the Primary Maximum Field-of-View.

4.3.4 Qualitative Considerations

After the quantitative considerations have been applied to the retrofit installation design, a qualitative assessment of the information being displayed shall occur. Many other factors need to be considered when determining the acceptability of displayed information in the cockpit. These factors should include the following:

- Readability
- Clutter
- Pilot scan pattern
- Pilot workload
- Parallax
- Frequency of use and criticality
- Attention-getting
- Out-the-window correlation
- Pilot disorientation
- Illumination and glare

4.3.5 Qualitative Assessment

Assess the installation design before committing to implementation by answering the following:

- Is the system providing the necessary information to support the intended functions and to achieve the associated tasks?
- Is the level of detail, accuracy, integrity, reliability, timeliness, and update rate of the information matched appropriately to the task associated with the intended function?
- Does the use of the system impair the pilot's ability to use other systems or do other tasks?
- Does the system or the use of the system impair the safe operation or the intended function of other systems or equipment?

If any of the above considerations are not sufficiently met, adjust the design.

4.4 Volumetric Requirements

The following figures provides the volumetric space required by the HDX800 and HDX1100 display units (with and without optional avionics trays), Standby Displays, and the optional Control Panels. All volumetric space dimensions include additional space for the "worst-case" electrical connectors and harnesses bent 90 degrees at minimum bend radius.

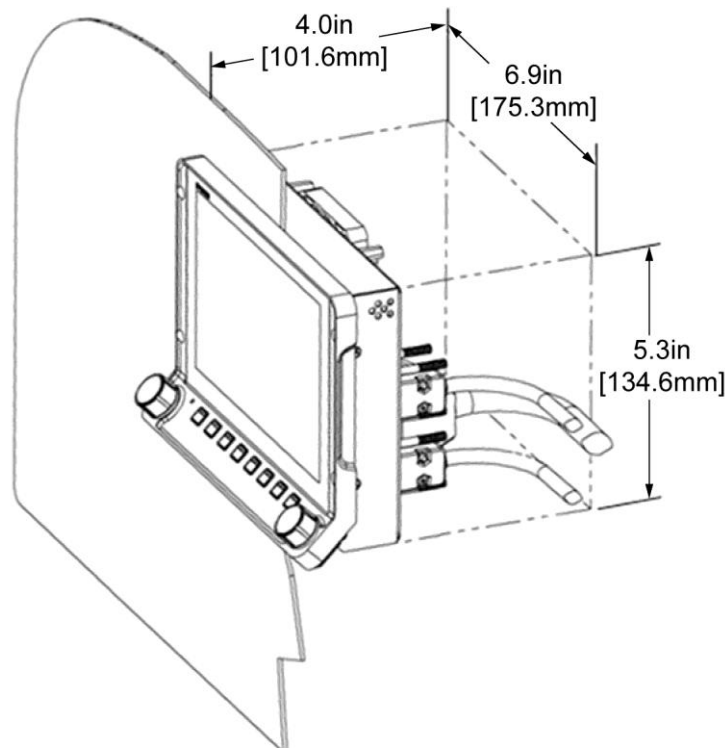

Figure 8: SkyView HDX800 Display Unit

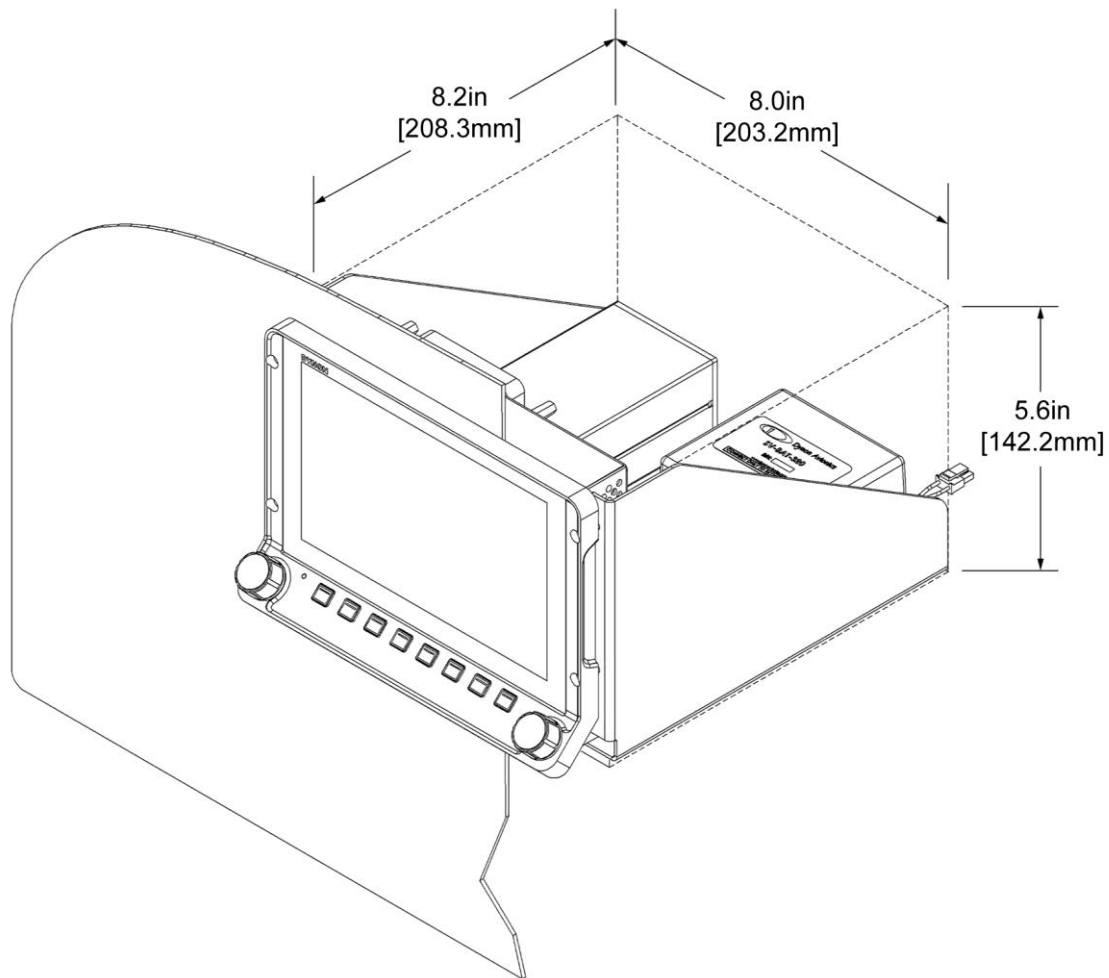

Figure 9: SkyView HDX800 Display Unit with an Avionics Tray

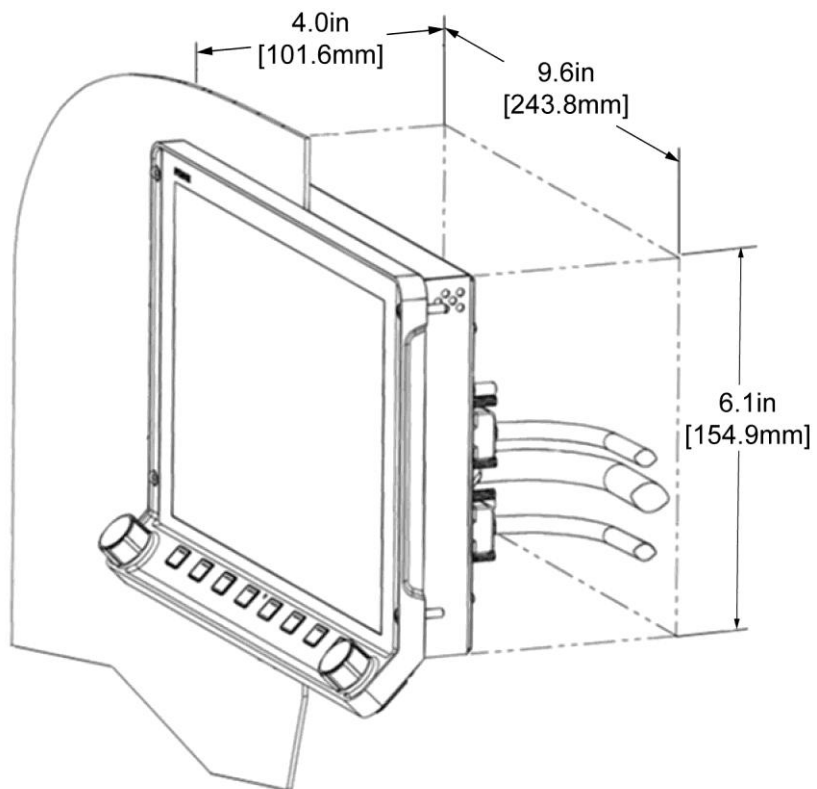

Figure 10: SkyView HDX1100 Display Unit

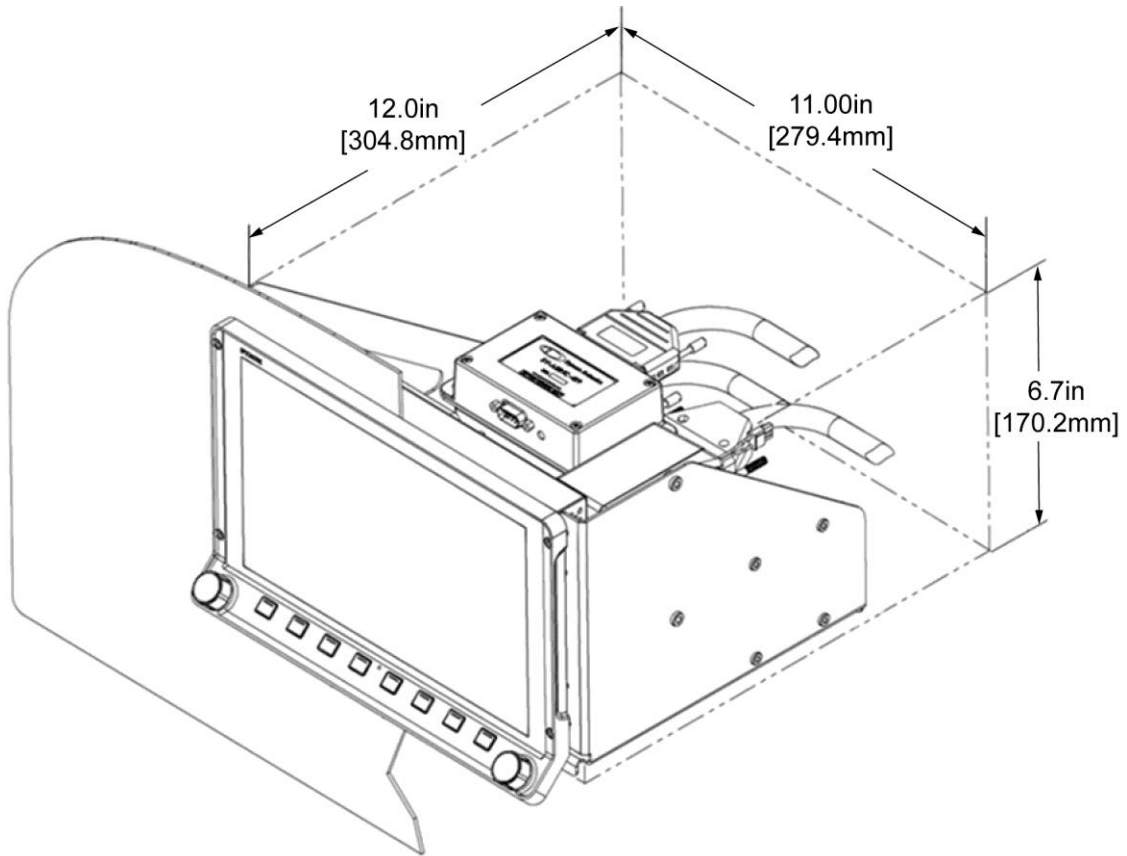

Figure 11: SkyView HDX1100 Display Unit with an Avionics Tray

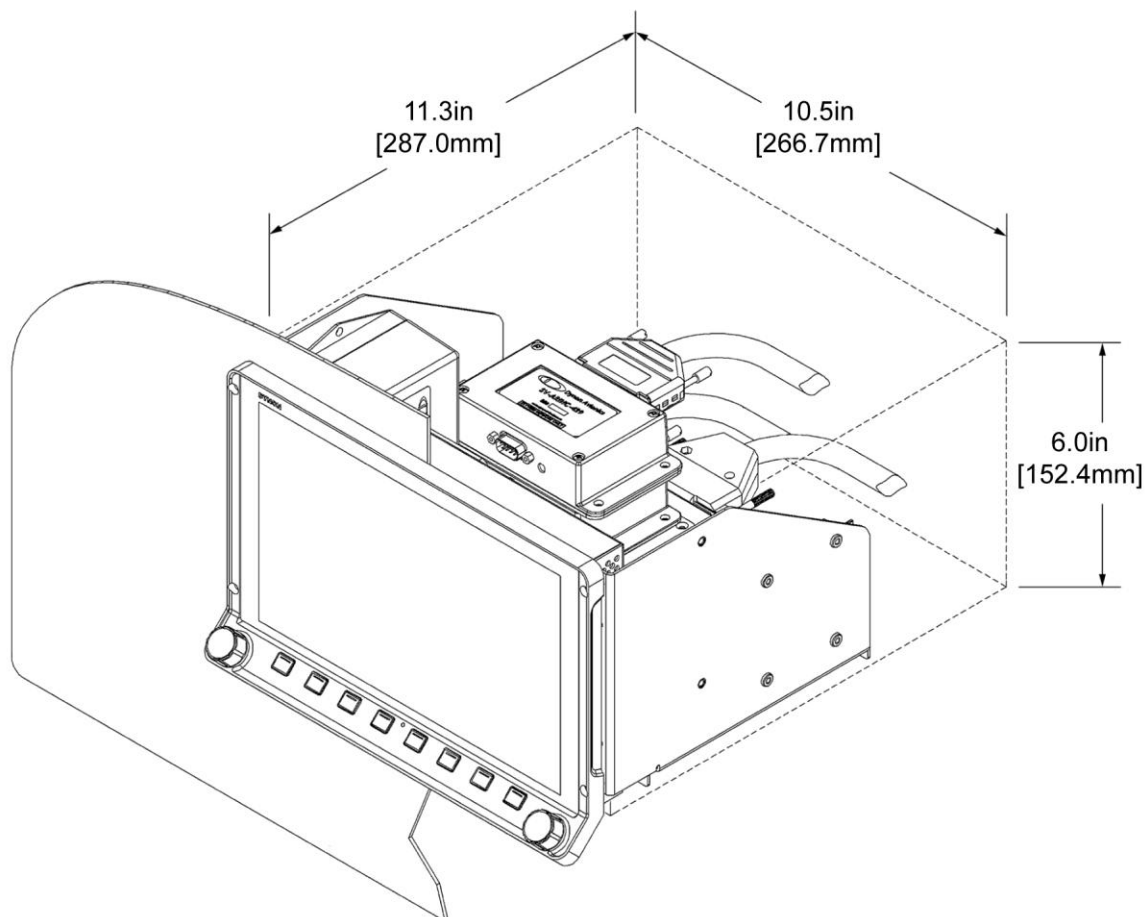

Figure 12: SkyView HDX1100 Display Unit with a Universal Module Mounting Tray

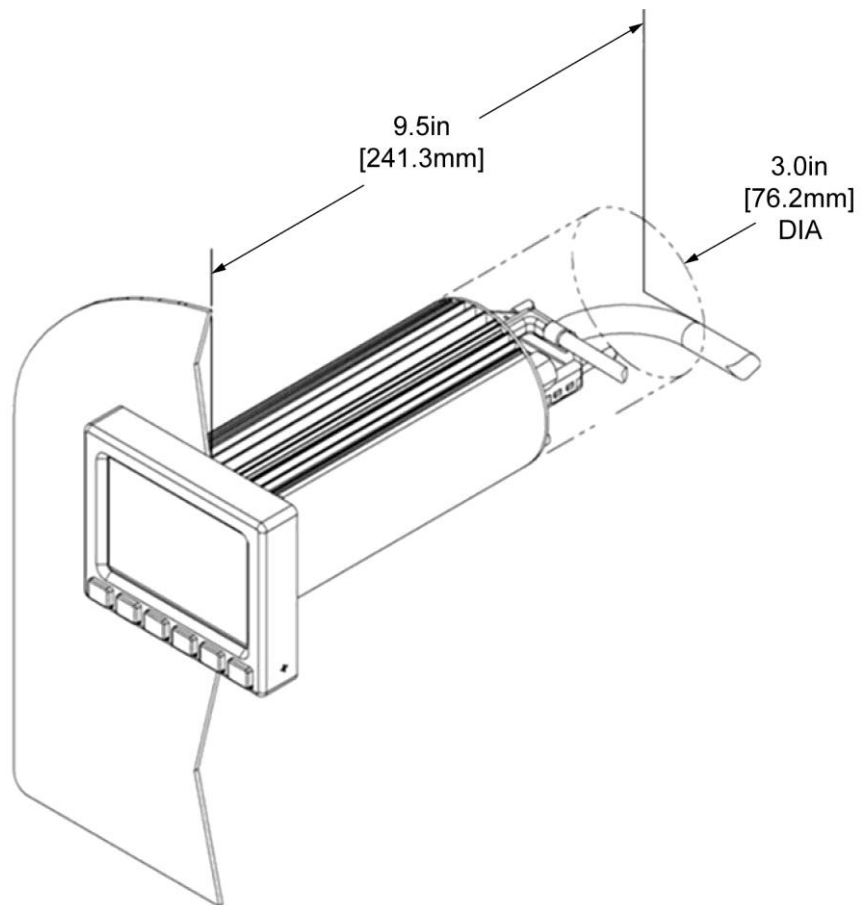

Figure 13: EFIS-D10A Standby Display Unit

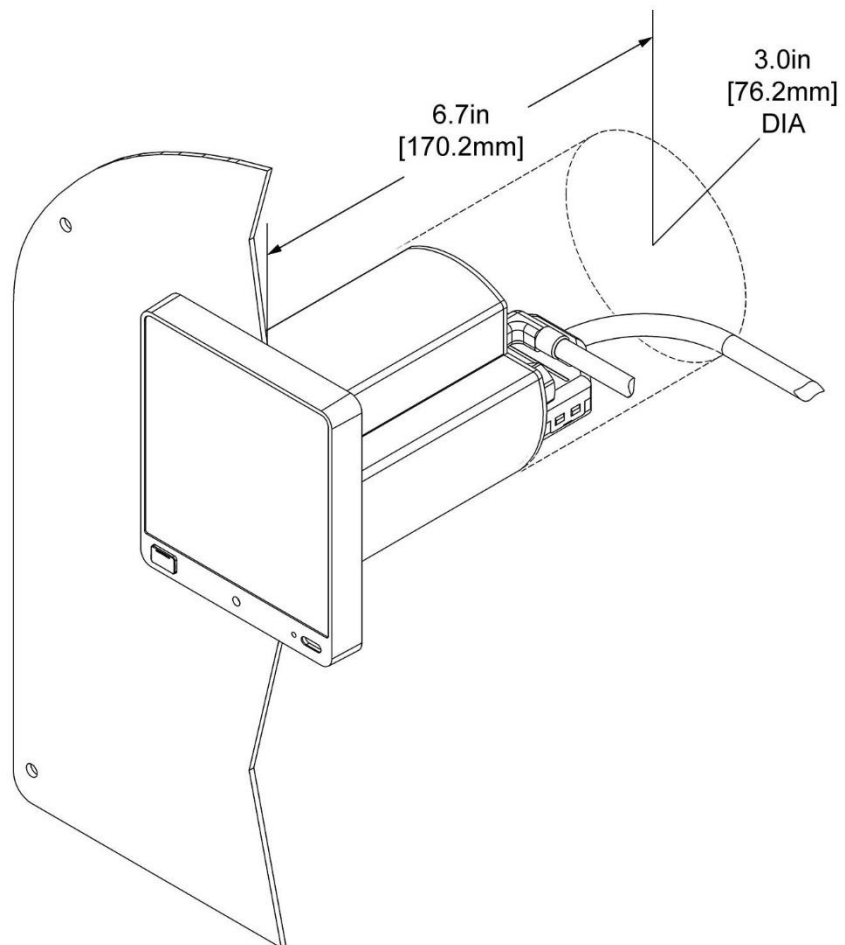

Figure 14: D30 Standby Display Unit

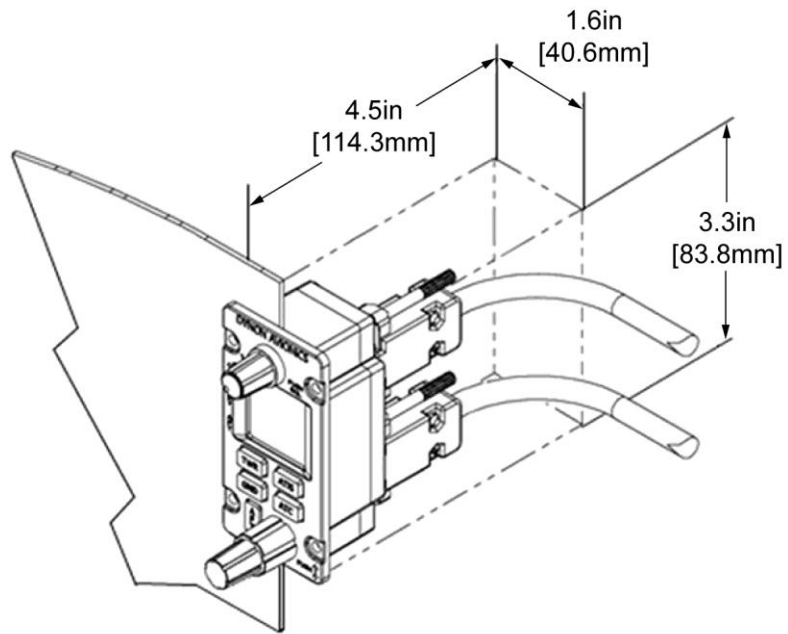

Figure 15: Typical SkyView Control Panel Module

5 Installation Aids

Dynon Avionics offers several installation aids, including avionics equipment trays, module stacking kits, and a radio stack module mounting kit. These aids help installers with instrument panel design, space planning, and equipment installation and connection. See Table 9 for a list of available installation aids, specifications, and usage.

Avionics trays provide orderly mounting of SkyView HDX display units and SkyView components. They have strategically-located nutplates for easy mounting of components and pre-drilled holes for easy riveting to an instrument panel.

Module stacking kits allow installers to combine EMS, ADAHRS, and ARINC modules, or a combination thereof, into one installable unit. Stacked modules maximize space and reduce installation and electrical connection efforts.

The radio stack module mounting tray provides orderly mounting of SkyView COM transceivers and transponders. It attaches to the avionics radio stack in most airplanes. This allows the SkyView radios to be installed in a location near the original radio equipment. Using the radio mounting tray simplifies the installation because it positions the new equipment near existing power and ground wires and antenna cables.

Table 9: Available Installation Aids

NAME	PART NUMBER	DIMENSIONS (W x H x L)	WEIGHT	ATTACHABLE COMPONENTS / NOTES
7" Avionics Tray for SV-HDX800 (See Figure 16 for example.)	503485-000	8 x 5.5 x 8.2 in. [203 x 140 x 208 mm]	0.77 lb. [0.35 kg]	<ul style="list-style-type: none"> SV-HDX800 Display SV-BAT-320 Backup Battery SV-COM-T25/T8 COM Radio Transceiver, or SV-XPNDR-261 Transponder
SV-HDX1100 Universal Module Mounting Tray Kit (See Figure 17 for example.)	504011-000	10.6 x 5.9 x 7.6 in [268 x 150 x 193 mm]	0.78 lb. [0.35 kg]	<ul style="list-style-type: none"> SV-HDX1100 Display SV-BAT-320 Backup Battery SV-NET-HUB Network Hub SV-ADSB-472 Receiver SV-EMS-220 EMS Module SV-ADAHRS-200 ADAHRS Module SV-ARINC-429 Interface Module
COM/XPNDR Radio Stack Module Mounting Kit (See Figure 18 for example.)	503756-000	6.3 x 2.6 x 9.5 in [160 x 65 x 241 mm]	0.31 lb. [0.14 kg]	<ul style="list-style-type: none"> SV-COM-T25/T8 COM Radio Transceiver SV-XPNDR-261 Transponder

NAME	PART NUMBER	DIMENSIONS (W x H x L)	WEIGHT	ATTACHABLE COMPONENTS / NOTES
EMS to ADAHRS/ARINC Module Stacking Kit (See Error! Reference source not found. and Figure 17 for examples.)	503963-000	5.3 x .09 x 2.6 in [135 x 2 x 66 mm]	0.06 lb. [0.02 kg]	Allows an ADAHRS or ARINC module to be mounted on top of an EMS module.
ADAHRS to ARINC Module Stacking Kit (See Error! Reference source not found. and Figure 17 for examples.)	503403-000	4.7 x .08 x 2.6 in [119 x 2 x 66 mm]	0.06 lb. [0.02 kg]	Allows an ARINC module to be mounted on top of an ADAHRS module.

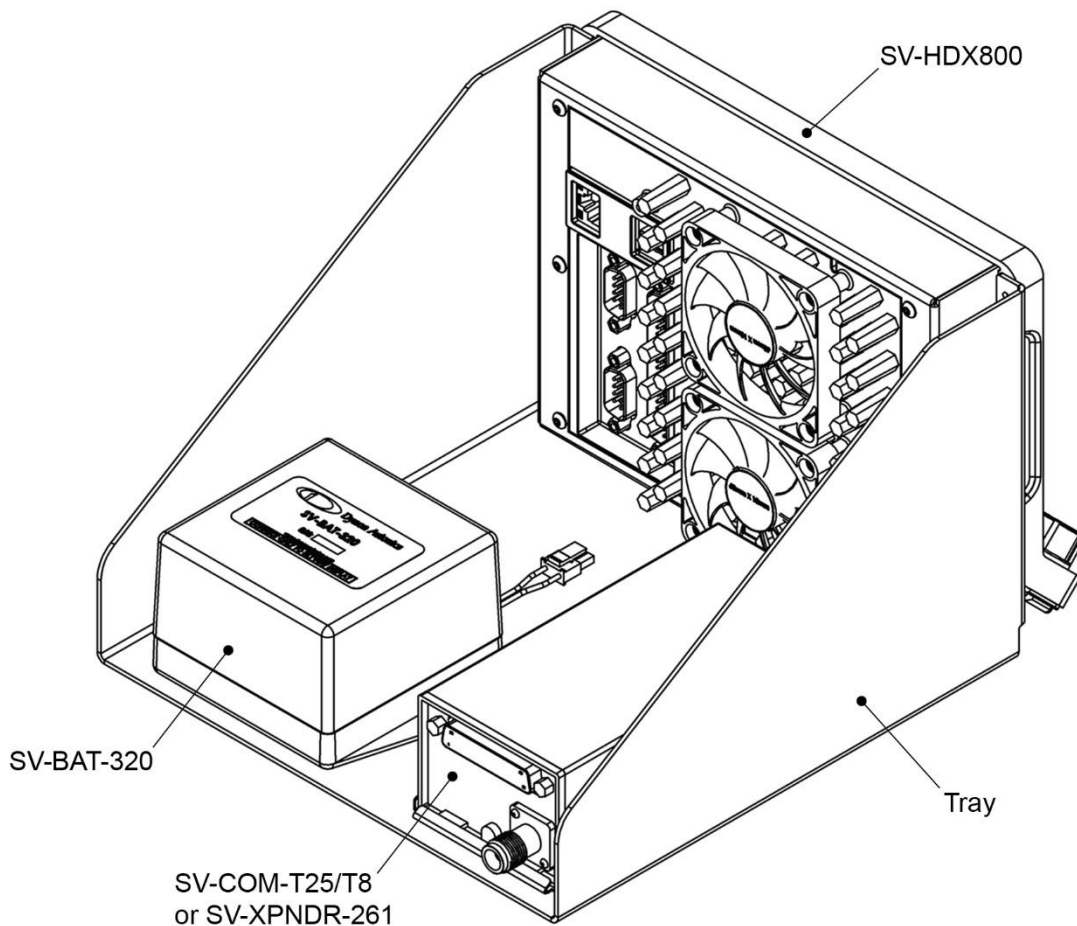

Figure 16: Typical Usage of a 7" Avionics Tray for SV-HDX800

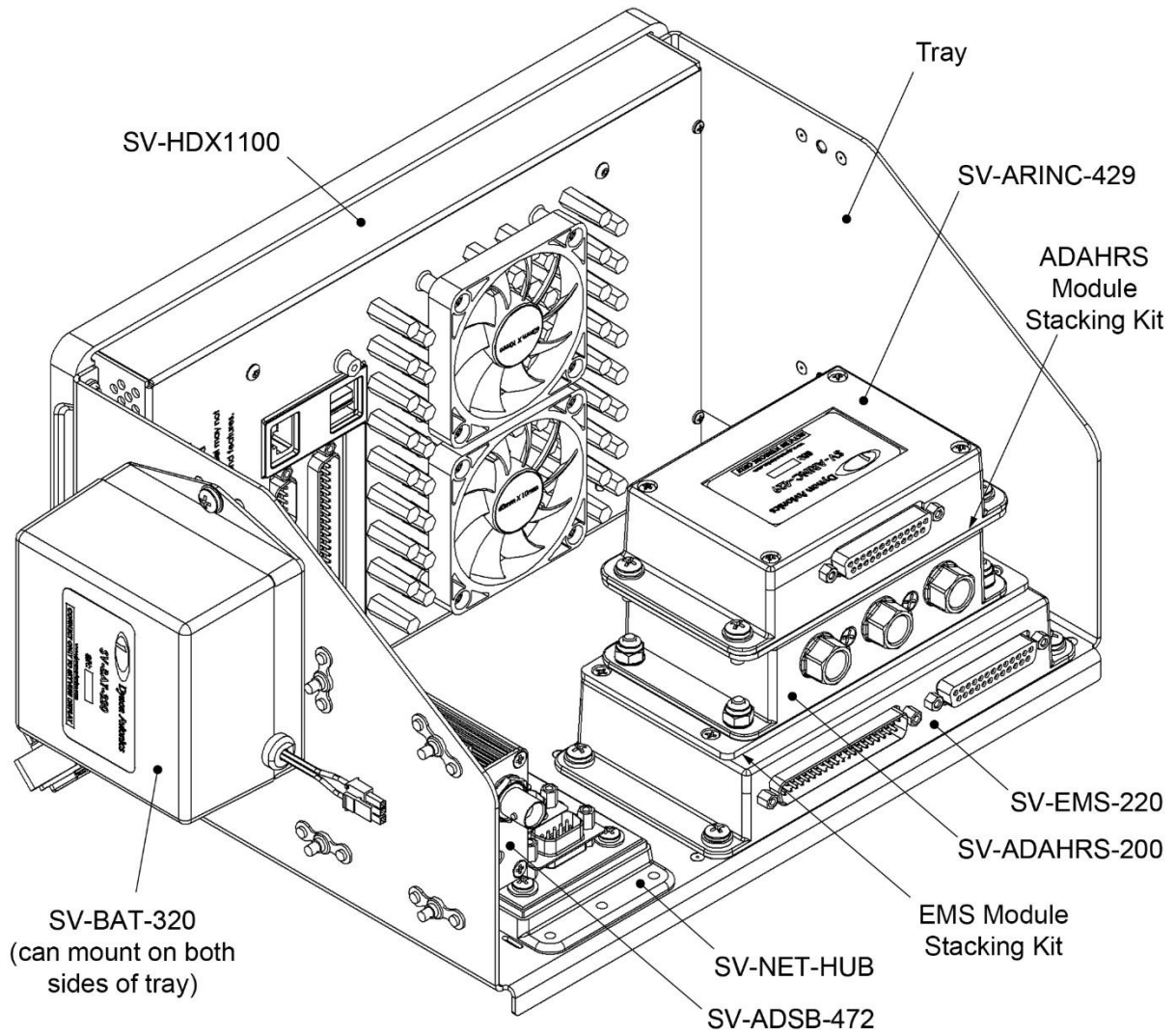

Figure 17: Typical Usage of an SV-HDX1100 Universal Module Mounting Tray Kit

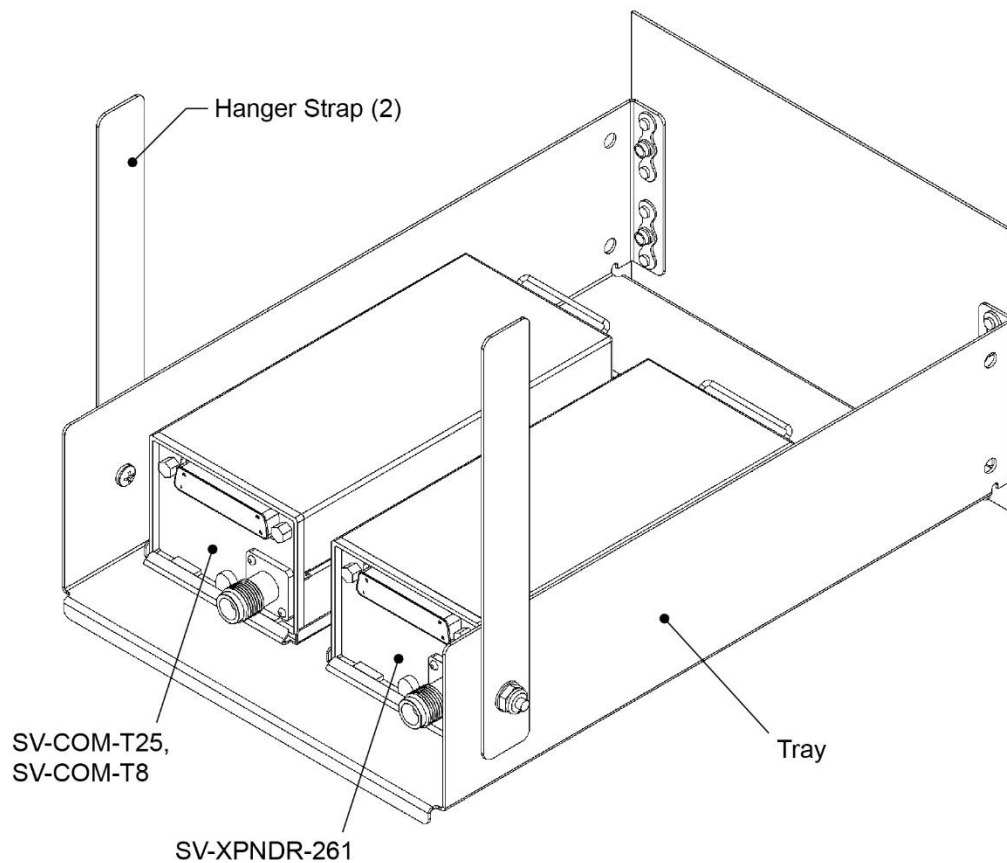

Figure 18: Typical Usage of a COM/XPNDR Radio Stack Module Mounting Kit

5.1 Avionics Trays

This section provides instructions and drawings for attaching Dynon avionics trays to an instrument panel.



Due to differing instrument panel material thicknesses, installers need to source appropriate AN/MS standard 3/32" rivets for tray attachment to instrument panel.



If attaching a Dynon avionics tray to an existing instrument panel, the panel's material thickness must be at least 0.02".

The SV-HDX1100 Universal Module Mounting Tray Kit includes all hardware required to mount the components shown in Figure 17. Installers need to source similar hardware to mount components to the 7" Avionics Tray for SkyView HDX.

Table 10: Materials – All Avionics Trays

DESCRIPTION	QTY
STABILIZING STRAP (Dynon Part # 504244-000)	1
PHILLIPS HEAD MACHINE SCREW #8-32, 1/4" (MS35206-241)	1
FLAT WASHER #8 (AN960-8)	1
LOCK NUT #8-32 (AN365-832A)	1

Table 11: Materials – SV-HDX1100 Universal Module Mounting Tray Kit

DESCRIPTION	APPLICATION	QTY
PHILLIPS HEAD MACHINE SCREW #8-32, 7/16" (MS35206-244)	SV-EMS-220, SV-ARINC-429 SV-BAT-320	8
FLAT WASHER #8 (AN960-8)	SV-EMS-220, SV-ARINC-429 SV-BAT-320	8
PHILLIPS HEAD MACHINE SCREW #6-32, 3/4" (MS35206-232)	SV-NET-HUB	4
PHILLIPS HEAD MACHINE SCREW #6-32, 7/16" (MS35206-229)	SV-ADSB-472	4
FLAT WASHER #6 (AN960-8)	SV-NET-HUB SV-ADSB-472	8

To attach an avionics tray to an instrument panel:

1. Prepare instrument panel for cutting using physical and panel cut-out dimensions in the following:
 - 7" Avionics Tray for SV-HDX800 Display – Figure 19 and Figure 20.
 - SV-HDX1100 Universal Module Mounting Tray Kit – Figure 21 and Figure 22.
2. Cut an opening for display unit in instrument panel. Make sure instrument panel opening includes necessary margins for paint or other applied finishes.
3. Clamp avionics tray into position around opening.
4. Use avionics tray as template to mark rivet hole and screw hole locations. Remove avionics tray when done.
5. Drill and deburr mounting holes. Use #40 drill for rivets and #16 drill for screws.
6. Countersink rivet holes on pilot-facing side of instrument panel. This allows rivets to be flush with face of instrument panel.
7. Secure avionics tray to instrument panel with 3/32" rivets.
8. If required, install a stabilizing strap to further support tray (see Figure 19 and Figure 21 for tray attachment points; see Figure 23 for tray attachment examples).

Dynon provides strap materials that will work with most installations. However, if a custom strap needs to be fabricated, it must meet the following minimum specifications:



- Material: AMS4117
- Material Thickness: 0.063"
- Strap Cross Section: 3/4" x 3/4"
- Maximum Strap Length: 14"
- Minimum Take-off Angle from Tray: 45°
- Attachment: Single #8-32 Fastener (both ends)

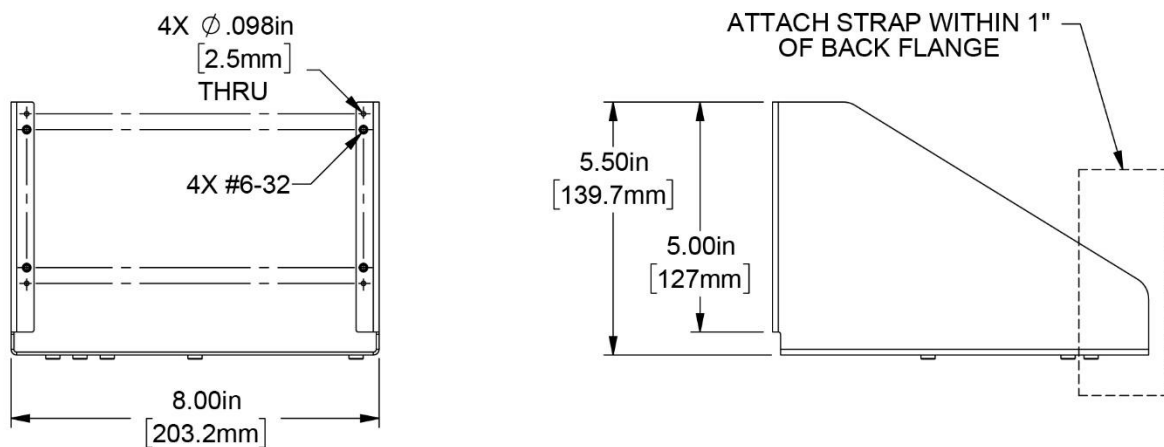
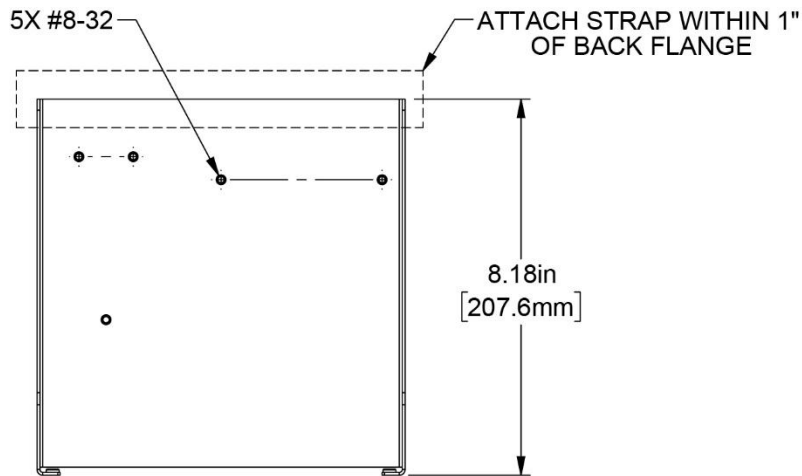

Figure 19: Physical Dimensions – 7" Avionics Tray for SV-HDX800

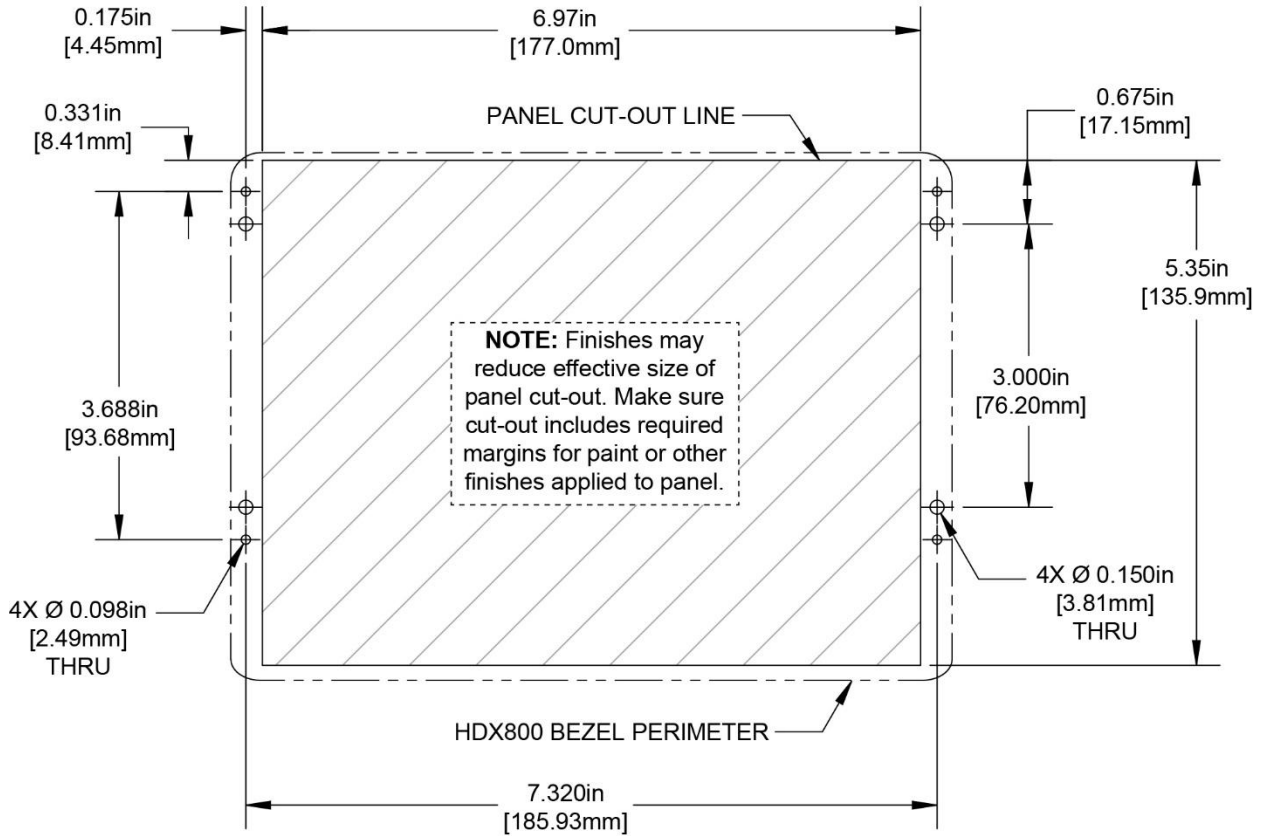

Figure 20: Panel Cut-out Dimensions – SV-HDX800 Display

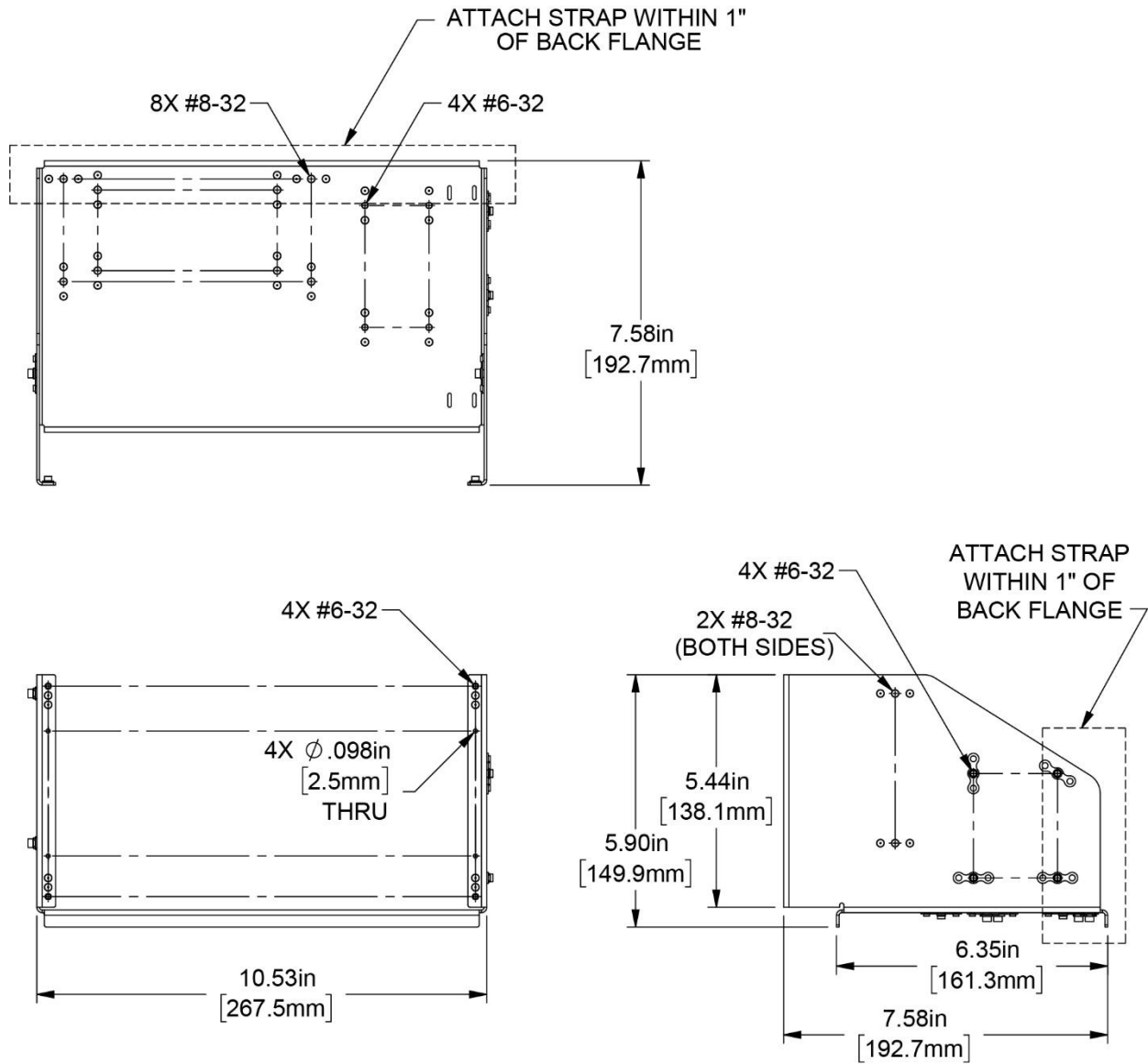

Figure 21: Physical Dimensions – SV-HDX1100 Universal Module Mounting Tray Kit

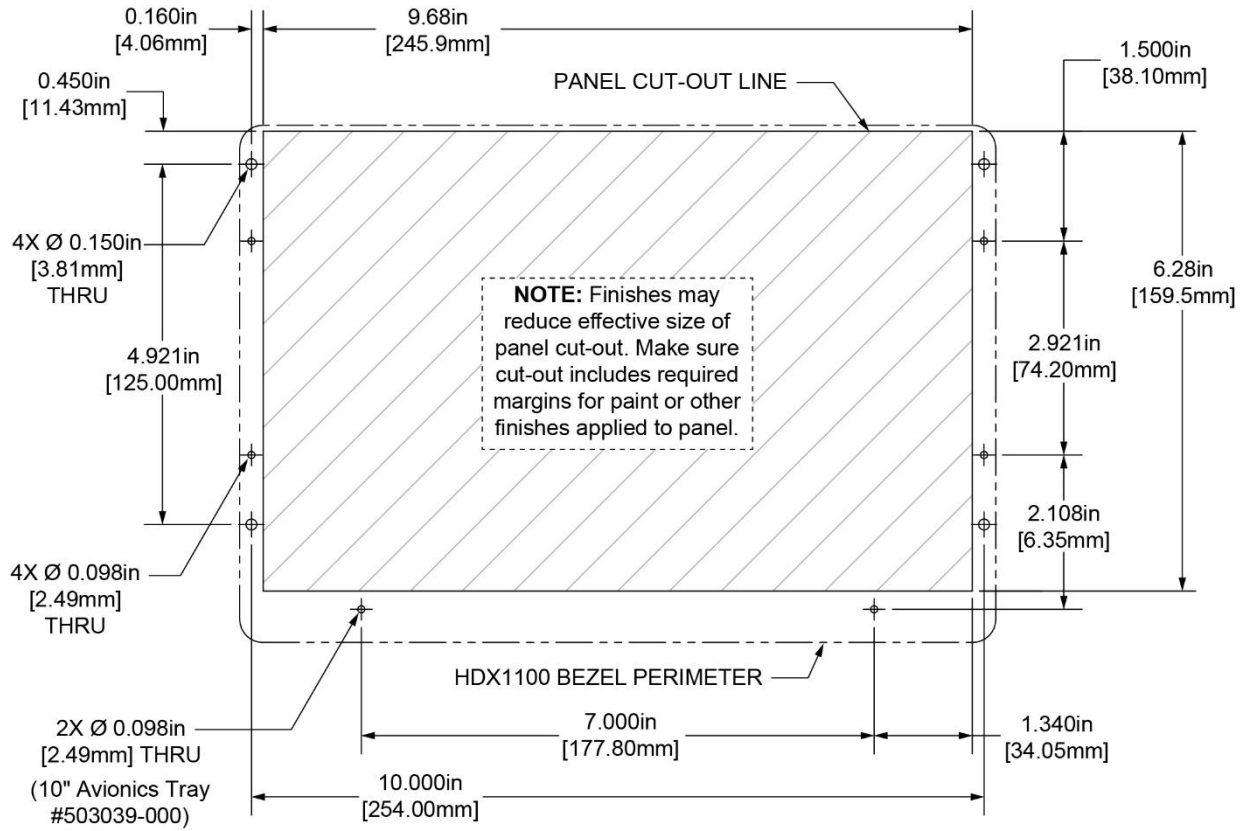

Figure 22: Panel Cut-out Dimensions – SV-HDX1100 Display

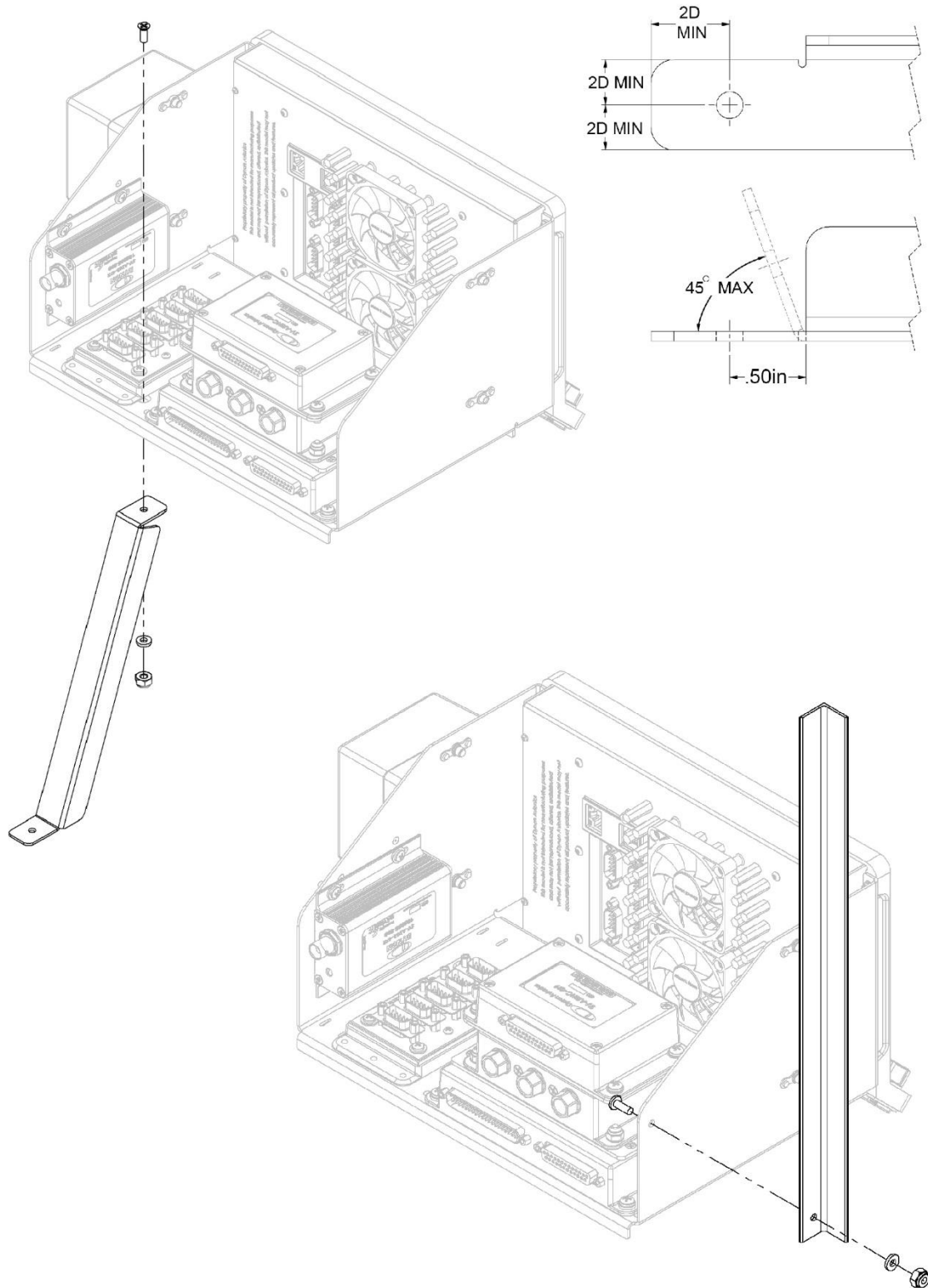

Figure 23: Stabilizer Strap Attachment Examples

5.2 Module Stacking Kits

This section provides instructions and drawings for using Dynon module stacking kits. Each kit includes a stacking plate and the required hardware. The EMS kit is used to attach an ADAHRS or ARINC module to an EMS module; the ADAHRS" kit is used to attach an ARINC module to an ADAHRS module.

The materials identified in Table 12 are provided with the EMS to ADAHRS/ARINC Module Stacking Kit and the ADAHRS to ARINC Module Stacking Kit. ITEM numbers call-out parts in Figure 24.

Table 12: Materials – Module Mounting Kits

ITEM	DESCRIPTION	QTY
EMS to ADAHRS/ARINC Module Stacking Kit		
1	PHILLIPS COUNTERSUNK MACHINE SCREW #4-40, NYLOK (Dynon Part # 101040-000)	4
2	FLAT WASHER #8 (AN960-8)	4
3	LOCK NUT #8-32 (AN365-832)	4
ADAHRS to ARINC Module Stacking Kit		
4	PHILLIPS COUNTERSUNK MACHINE SCREW #4-40, STAINLESS, NYLOK (Dynon Part # 102544-000)	4
5	PHILLIPS PAN HEAD MACHINE SCREW #8-32, 3/8", STAINLESS (MS35206-243)	4
6	STAR WASHER INTERNAL #8, STAINLESS (MS35333-72)	4

To attach a module to another module using a stacking kit:

1. Remove 3 of 4 screws that secure module housing cover to housing body.



DO NOT remove housing cover or tamper sticker! Doing so will void warranty on module.

2. Use provided screws to secure stacking plate to module (see Figure 24).



DO NOT over tighten screws! Doing so may strip threads in module housing.

3. Attach module to stacking plate using provided fasteners, as shown in Figure 24.

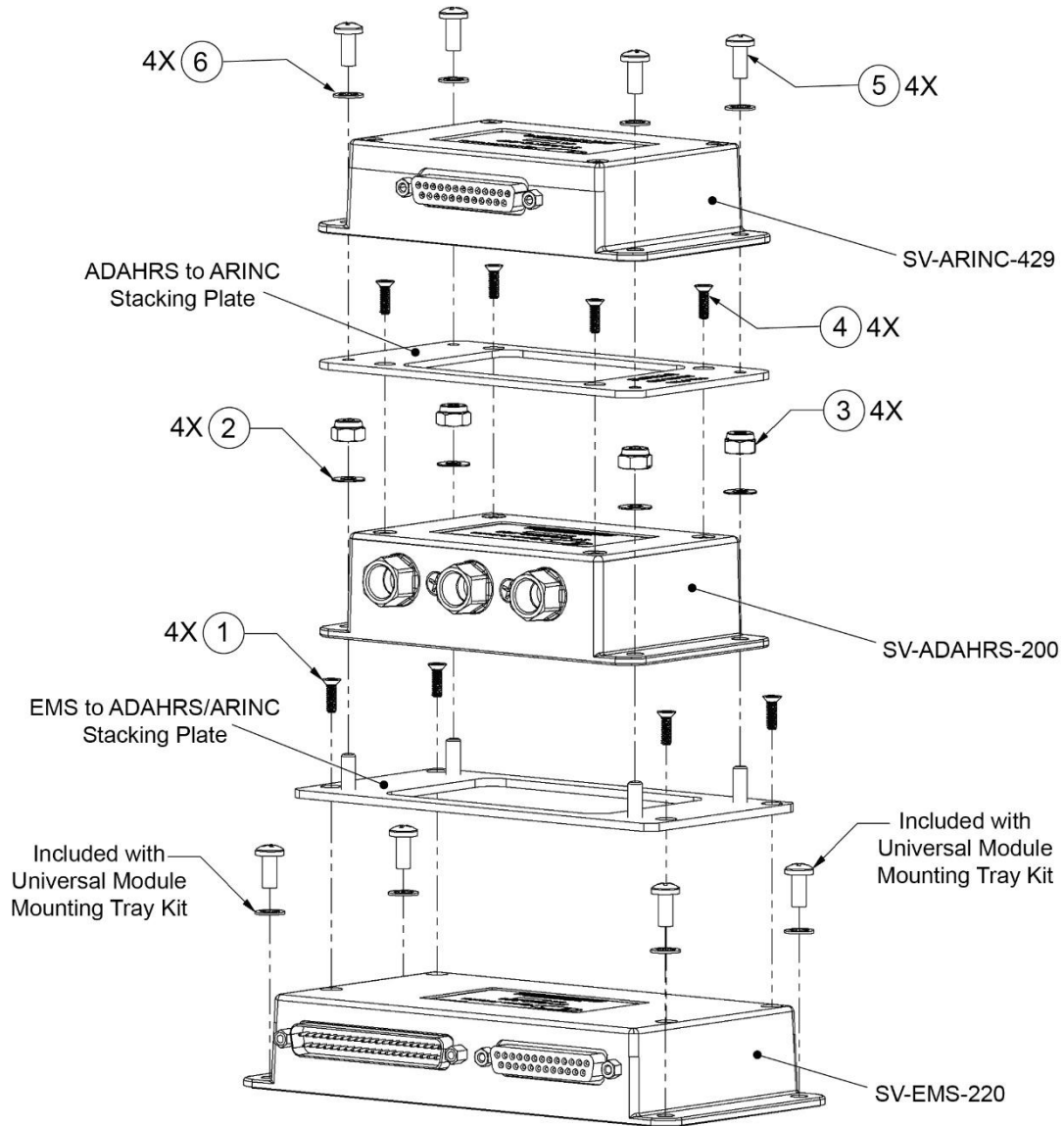

Figure 24: Module Stacking Kits – Module Attachment

5.3 Radio Stack Module Mounting Kit

This section provides instructions and detailed drawings for attaching a COM/XPNDR Radio Stack Module Mounting Kit to an avionics stack.



The radio stack module mounting kit includes hanger straps and most fasteners. Due to differing space requirements, installers need to source appropriate AN/MS standard fasteners for hanger strap attachment to radio stack structure.



The radio stack module mounting kit can be mounted inverted (see Figure 27), provided it is located on the bottom of the avionics stack. This allows access to equipment from underneath in airplanes that provide such access.

The materials identified in Table 13 are provided with the Radio Stack Module Mounting Kit. ITEM numbers call-out parts in Figure 26 and Figure 27.

Table 13: Materials – Radio Stack Module Mounting Kit

ITEM	DESCRIPTION	QTY
1	PHILLIPS HEAD MACHINE SCREW #6-32, 7/16" (MS35206-229)	6
2	FLAT WASHER #6 (AN960-6)	6
3	LOCK NUT #6-32 (AN365-632A)	6

To attach the radio stack module mounting kit to an avionics stack:

1. If needed, cut an opening in instrument panel using Figure 25 as a guide.



Reference Figure 26 and Figure 27 for remaining steps.

2. Position and clamp tray to existing structure.



Allow least 2.5" above/below radio modules. Radio modules cannot be secured or released from their brackets without a minimum clearance of 2.5".

3. Temporarily fasten hanger straps to both sides of tray.
4. Position and clamp hanger straps so they are centered over available holes in existing radio stack structure.



Other hanger straps may need to be fabricated if those provided are not ideal for the installation.

5. Match drill holes through existing radio stack structure using holes in tray as guides, and then temporarily fasten.

-
6. Match drill holes through hanger straps using holes in existing radio stack structure as guides, and then temporarily fasten.
 7. Trim hanger straps as needed for installation.
 8. Disassemble and deburr all holes and cuts.
 9. Reassemble with provided fasteners.
 10. If needed, trim cover to fit opening in instrument panel.
 11. Attach cover to instrument panel.

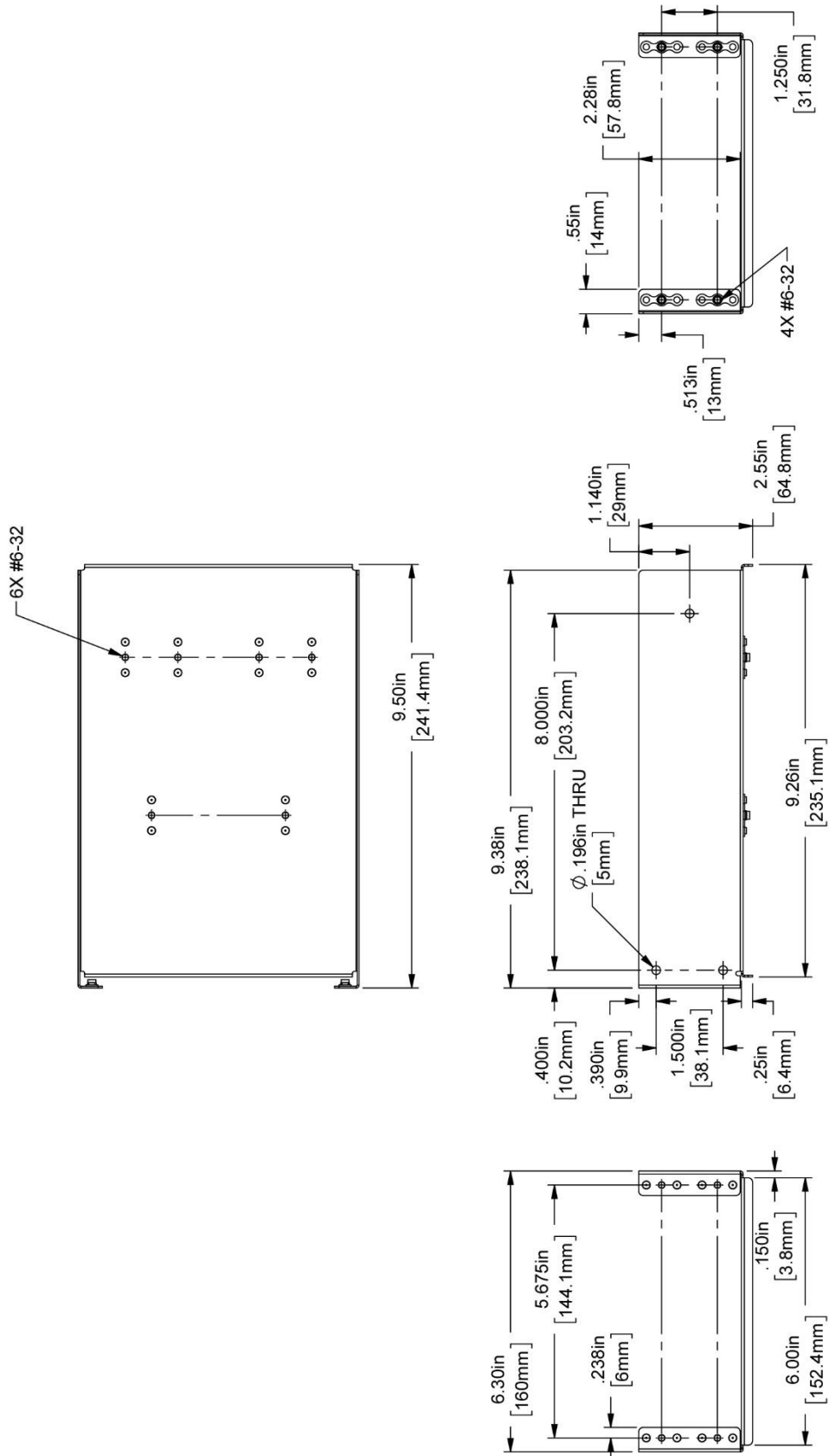

Figure 25: Dimensions – COM/XPNDR Radio Stack Module Mounting Kit

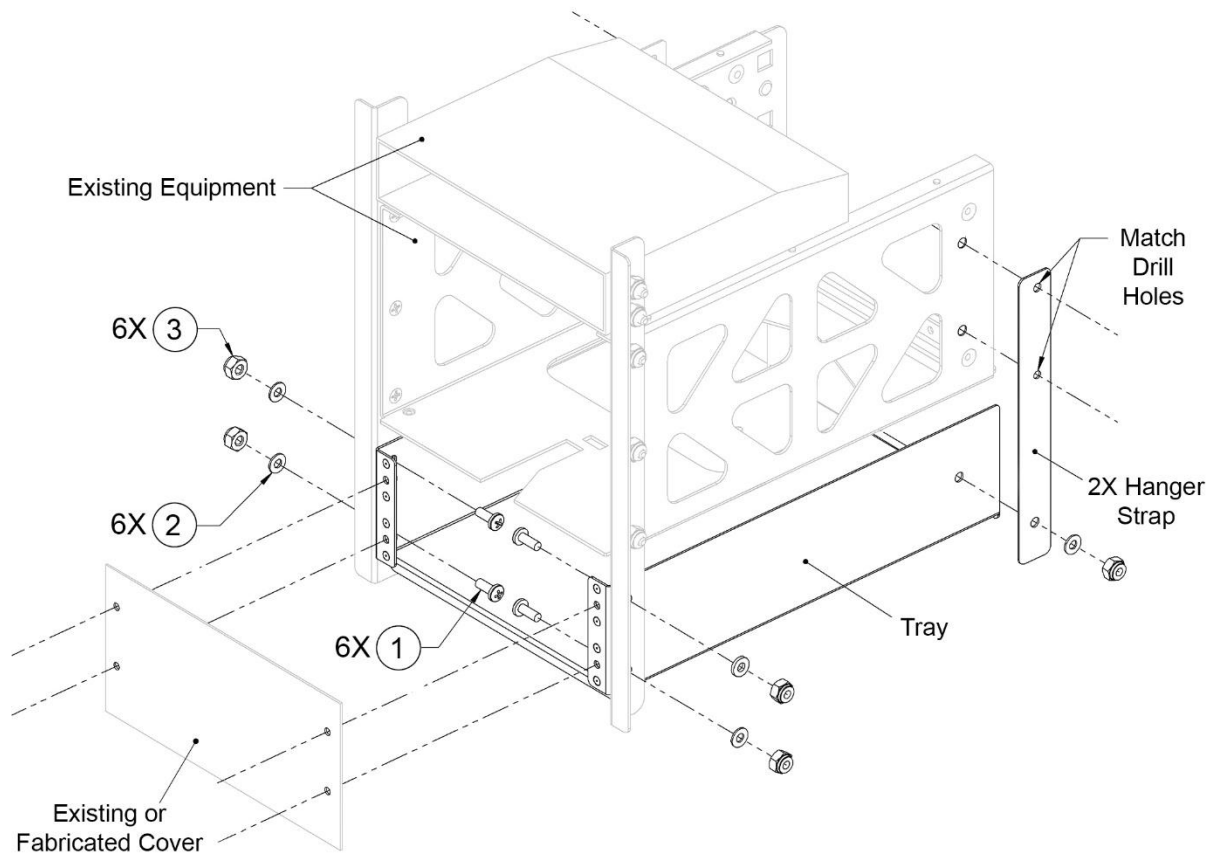

Figure 26: Example of Installing Radio Stack Module Mounting Kit in Upright Position

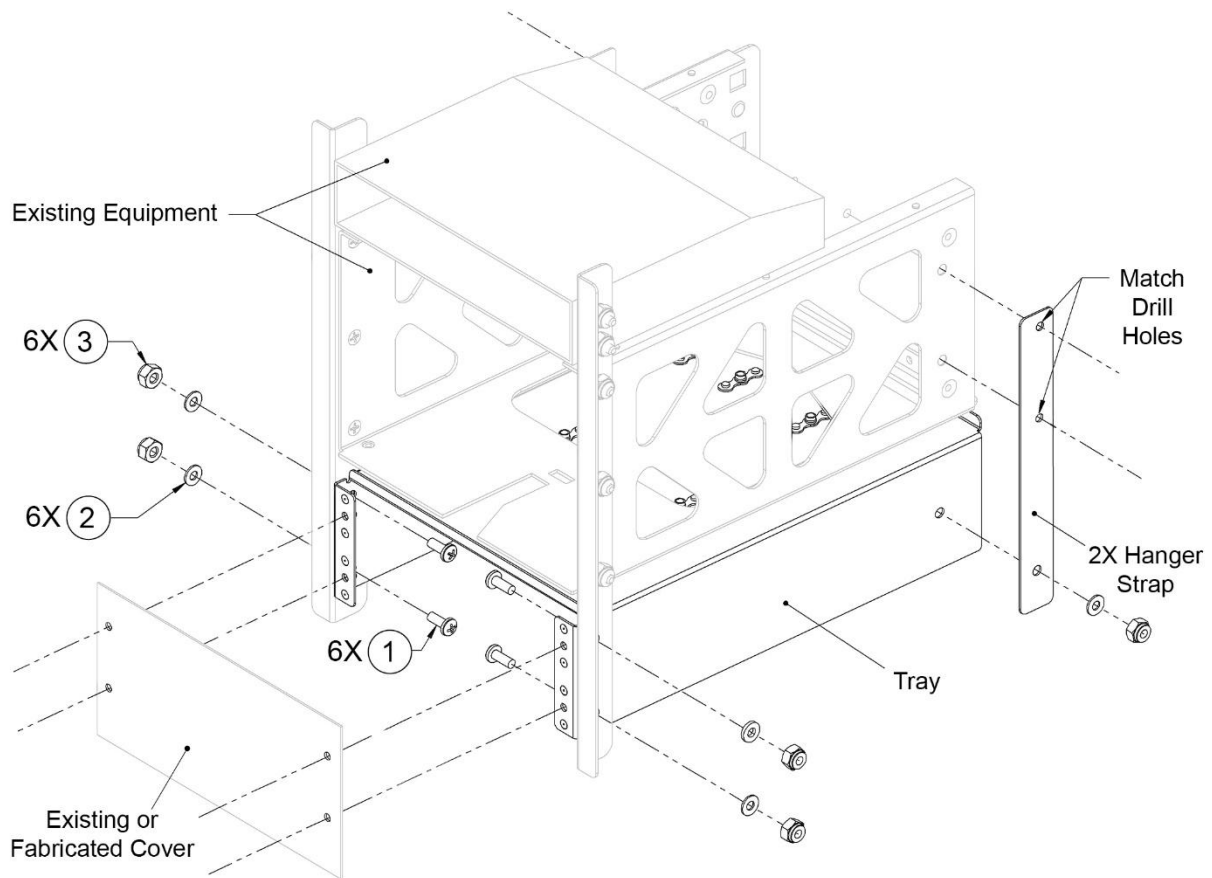

Figure 27: Example of Installing Radio Stack Module Mounting Kit in Inverted Position

6 SkyView HDX Display Units

This section contains information and diagrams that specifically apply to the installation of SkyView HDX System per STC SA02594SE. After reading this section, you should be able to determine how to prepare a panel for display installation, how to mount a display, how to make all necessary electrical connections, and how to generally configure the display. Airplane specific configuration will be described in the SkyView System Configuration Manual for your airplane.

- Consider the ease, or difficulty of disconnecting multiple connectors when removing a SkyView display from the panel. Plan for either:
 - Providing sufficient slack in the cables so that the SkyView display can be removed from the panel and *then* the cables disconnected, or
 - Disconnecting (and reconnecting) the cables from behind the panel prior to removing the SkyView display from the panel.
- The SkyView Display Harness (SV-HARNESS-D37) extends about 3" (76mm) from the back of the display.
- Add a 1.0" (25.4 mm), minimum, beyond the physically required volume for the SkyView display's heat sinks and fans to operate.
- Avoid placing the display near heater vents or any source of extremely hot air.



While SkyView displays do not normally require a forced cooling air, if the aircraft is to be operated in hot climates, the builder should ensure that the stated operating temperature range for SkyView displays is not exceeded.

- The display should be easily viewable without any obstructions.
- SkyView displays have no internal inertial sensors and do not need to be mounted in the same orientation as the ADAHRS or other modules.
- Displays only support a landscape viewing orientation; do not mount in portrait orientation.

Figure 29 and Figure 30 show the mechanical dimensions of the SkyView displays. Use the dimensions (in inches) in the diagrams to plan for the space required by the display.

To mount a SkyView display, cut an appropriately sized rectangular opening in your panel, drill out the mounting holes, and use the included mounting screws to fasten the display to the panel.

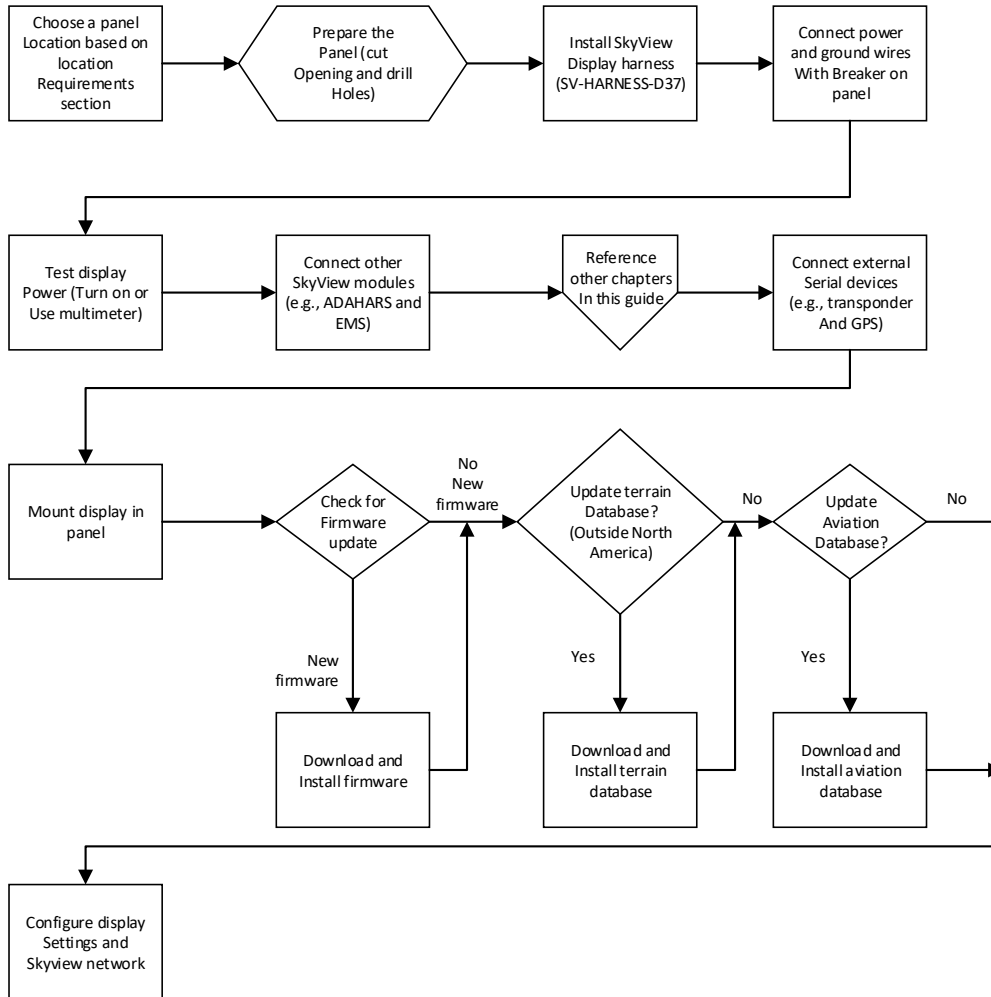

Figure 28: Suggested SkyView Display Installation Procedure

6.1 Mechanical Installation

Consider the ease, or difficulty of disconnecting multiple connectors when removing a SkyView display from the panel.

The following pages show the mechanical dimensions of the SkyView displays. Use the dimensions (in inches) found in the appropriate diagram to plan for the space required by the display.

To mount a SkyView display, cut an appropriately sized rectangular opening in your panel, drill out the mounting holes, and use the included mounting screws to fasten the display to the panel. See Figure 29 and Figure 30 for guidance.

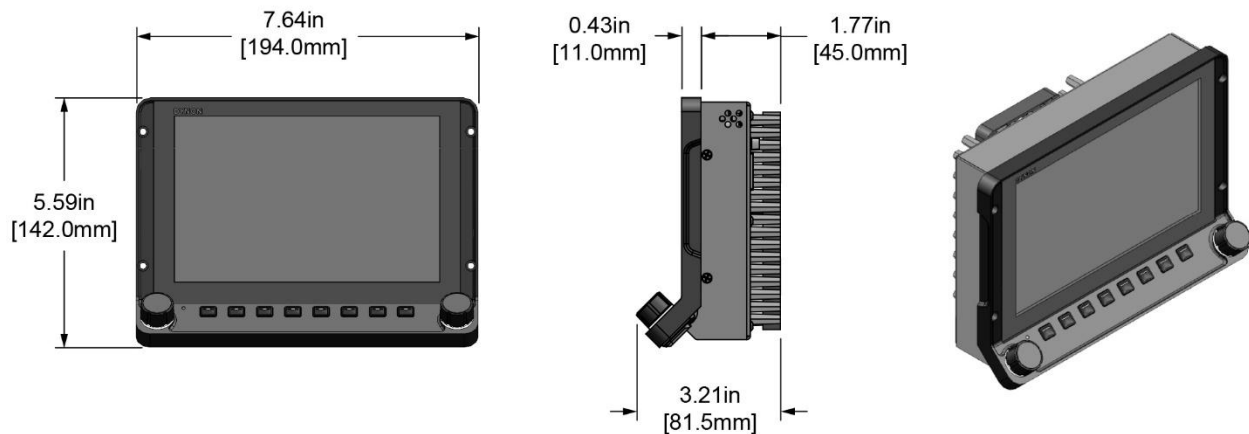
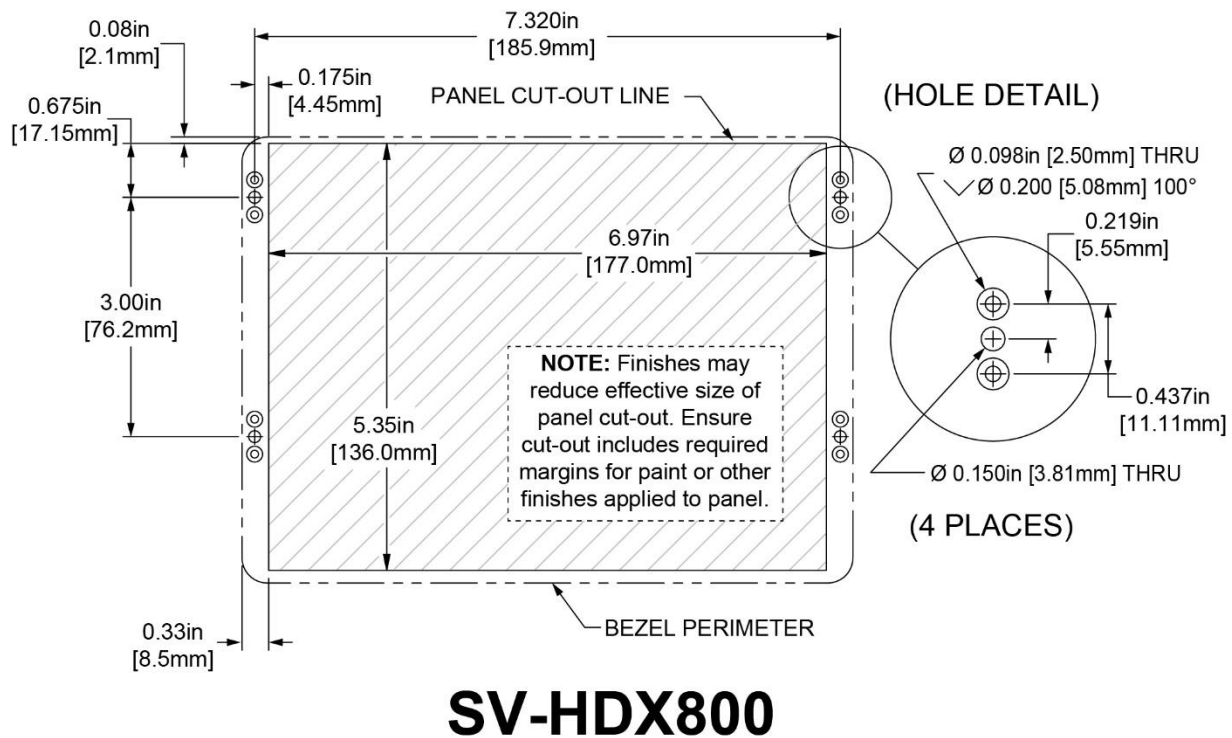

Figure 29: SV-HDX800 Panel Cut-out and Mounting Hole Dimensions

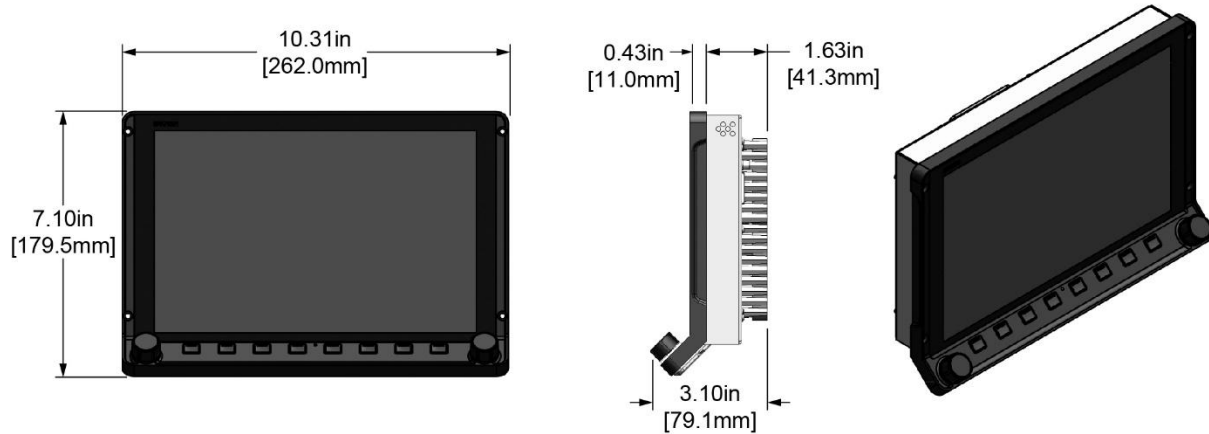
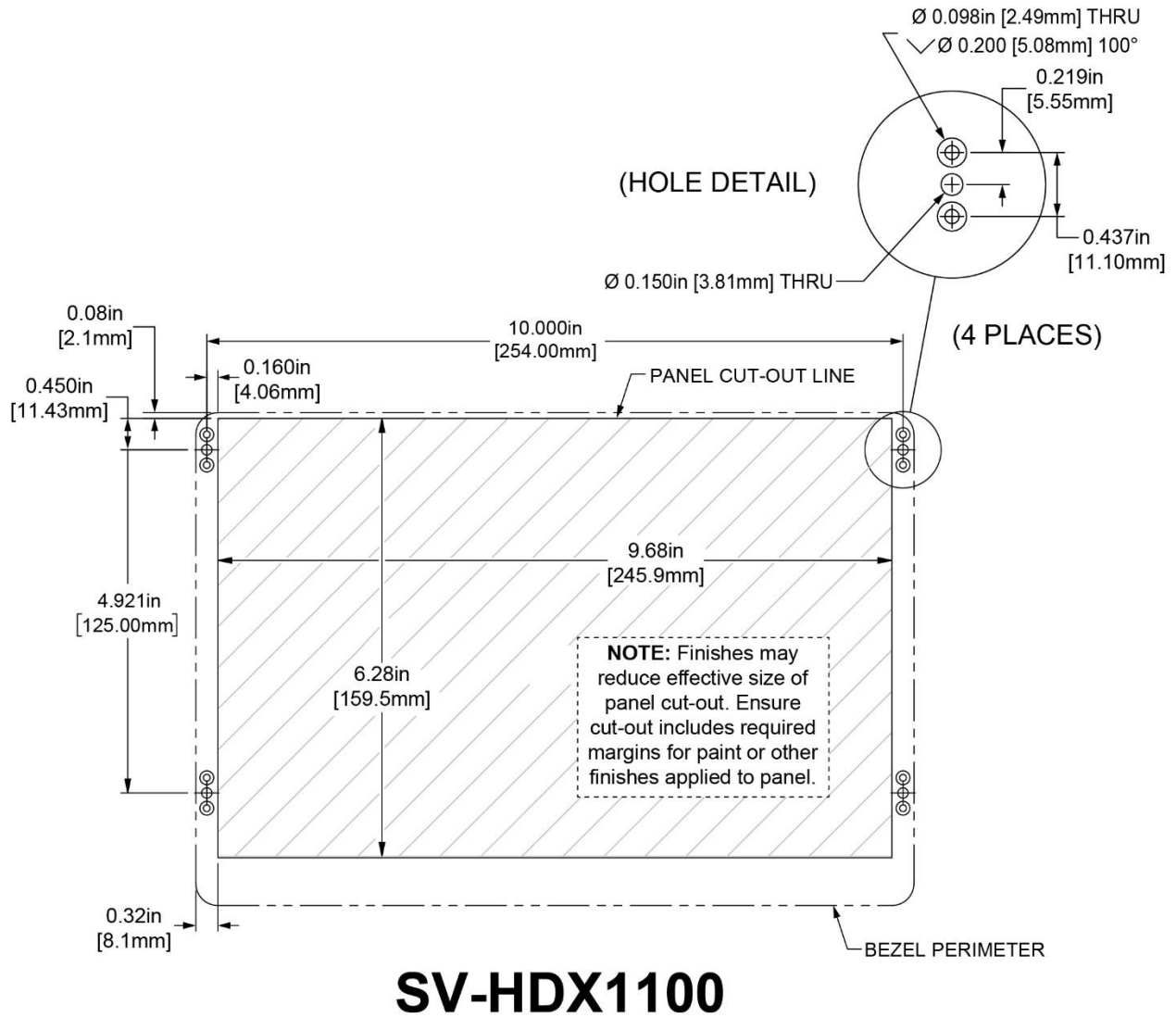

Figure 30: SV-HDX1100 Panel Cut-out and Mounting Hole Dimensions

6.2 Electrical Installation

Use this section in conjunction with the information contained in Section 31 *Appendix C: Wiring and Electrical Connections* (notably Figure 153 on page 331). The wires and wire colors in this section refer to the wires on the included SkyView Display Harness (SV-HARNES-D37).



Some wires that are used in SkyView harnesses are identified with secondary color stripes. Exposing these striped wires to solvents or abrasives can cause the stripe color to wear off. Handle these wires with care.

6.2.1 Power Input

SkyView displays have a primary power input that is compatible with 12-volt and 24-volt electrical systems (10 to 30 volts DC). There are two unterminated solid red primary power input wires (to reduce current loading in each wire - these are not for redundancy, and both must be connected to the same power source) and two unterminated solid black primary ground wires.



Ensure that there is an appropriately rated circuit breaker or replaceable fuse on the primary power input.

6.2.2 Grounding

Ensure that all external devices that interface with SkyView have a common ground with SkyView. If a device does not share ground with SkyView, it may not communicate properly.

6.2.3 Airplane Master Contactor / Relay Considerations

If your aircraft is equipped with a master contactor or a relay that is operated by the master switch, it is imperative that the coil of the contactor or relay is protected by a diode to reduce the voltage spike seen when the contactor is turned off. Without this diode, the aircraft system can see spikes above 100V, which can damage Dynon Avionics equipment and other avionics.

While some contactors have this diode internally, many do not. Please verify the existence of this diode before operating your Dynon Avionics equipment. Any diode that is rated for more than 1A, and more than 50V, is suitable.

6.2.4 SV-BAT-320 Connection and Operation Rules

SkyView displays have an external backup battery - SV-BAT-320. The SV-HARNES-D37 harness has a connector that mates with the connector on the SV-BAT-320. Simply connecting the display to the battery enables the use of the SV-BAT-320; no additional configuration is required.

In the event of an electrical failure that causes SkyView to run on the SV-BAT-320, the SV-BAT-320 supplies power to the SkyView display it is connected to, along with any devices powered by the SkyView. A fully charged SV-BAT-320 can keep most SkyView systems operating for at least 60 minutes. The SV-BAT-320 does not supply (backup) power to the following SkyView system devices:

- Autopilot servos.
- SV-ADSB-472.
- SV-COM-X25/X83.
- SV-XPNDR-261.
- Any non-Dynon Avionics device.



SkyView displays are only compatible with a Dynon Avionics SV-BAT-320 Backup Battery. Do not connect a lead-acid battery or any other battery to the connection reserved for the SV-BAT-320, as the charging algorithm and charging circuitry, voltages, etc., are optimized for the SV-BAT-320. Connecting any other battery may have detrimental consequences. Damage caused by connecting such a battery will not be repaired under warranty.



See the Non-Dynon Avionics Wire Harness Considerations, section 31.4, for important specifications that must be adhered to for the SV-BAT-320 to charge properly when used with a non-Dynon Avionics harness.

6.2.5 SkyView Network Connectors

The two D9 connectors on the back of a SkyView display are SkyView network connectors. They have identical pinouts and are electrically connected inside the display (i.e., they are completely interchangeable). Installers may use either connector or both connectors in SkyView installations. See Section 31 *Appendix C: Wiring and Electrical Connections* for SkyView Network Connector pinout information.



Note that these connectors are not "RS-232" Serial Port connectors.

6.2.6 Network Setup and Status

Once all SkyView modules are connected in a network, either in a benchtop test or permanent installation, turn the display(s) on. You will see the display boot up and the status LEDs on the modules light up.



A tail number on the Aircraft Information Page (SETUP MENU > SYSTEM SETUP > AIRCRAFT INFORMATION) is required for network configuration.

If you have more than one (1) display in your SkyView system, the tail number only needs to be set on the display that you initially perform the Network Configuration on. At network configuration time, all other displays that are set to the default tail number of DYNON will automatically have their settings and tail number synchronized with the display the configuration is performed from. After configuration, all displays' tail numbers and settings will be synchronized, and further setup tasks can be performed from any display.

When you first power up your SkyView display, it will look like the screen. *This is normal* – you have not yet performed a SkyView Network Configuration for the SkyView display(s) to recognize your ADAHRS, EMS, and other SkyView Network modules.

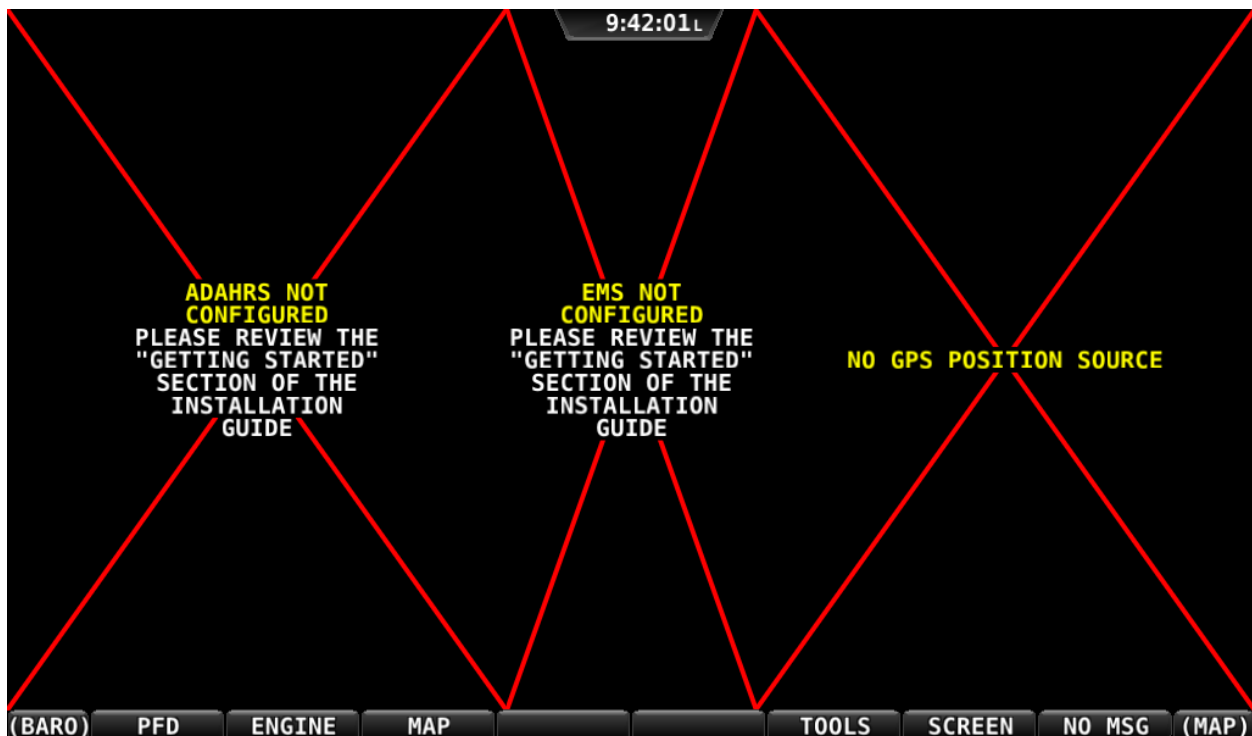

Figure 31: New SkyView display, SkyView Network not yet configured

Use the following procedure to configure a SkyView network:

1. Push buttons 7+8 to access the SETUP MENU.
2. *Navigate to the CONFIGURE Page* (SETUP MENU > SYSTEM SETUP > SKYVIEW NETWORK SETUP > CONFIGURE...).

3. Press *DETECT*. A successful network configuration yields the screen below (depending on the units installed, your SkyView system's network devices will look different and display different Software versions).
4. Press *FINISH* to close the screen and return to the Network Setup Menu.

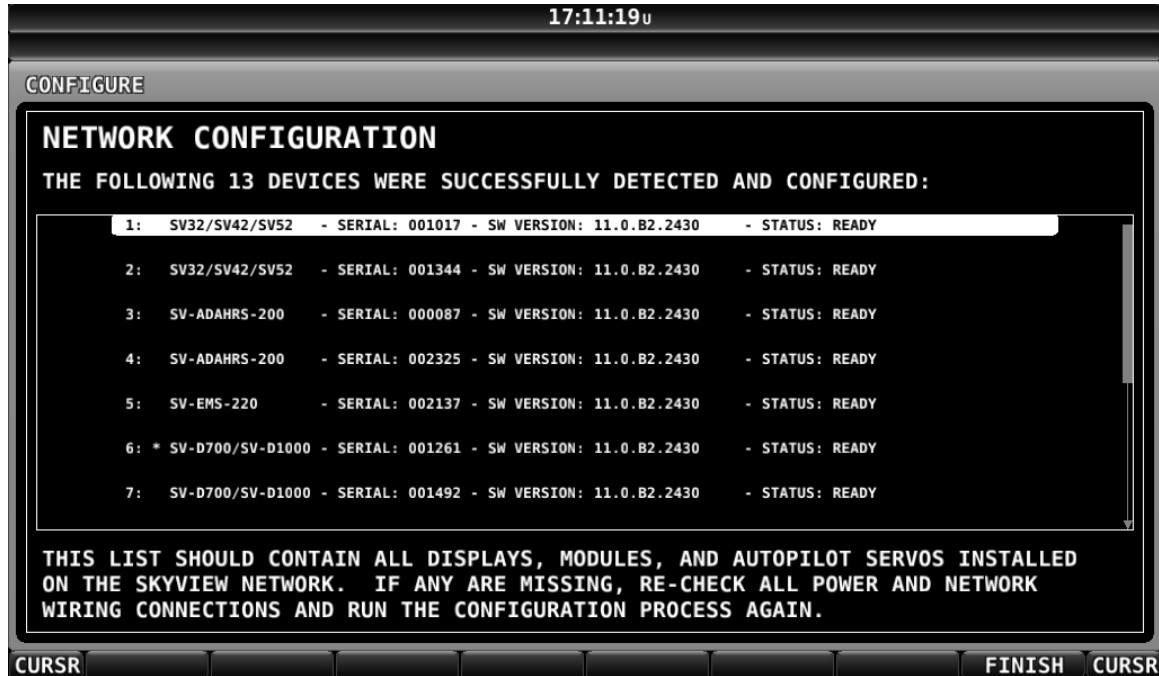

Figure 32: Successful SkyView Network Configuration Screen



If the SkyView network is successfully configured, but software versions on equipment are not synchronized, you will see a screen that is similar to the figure below.

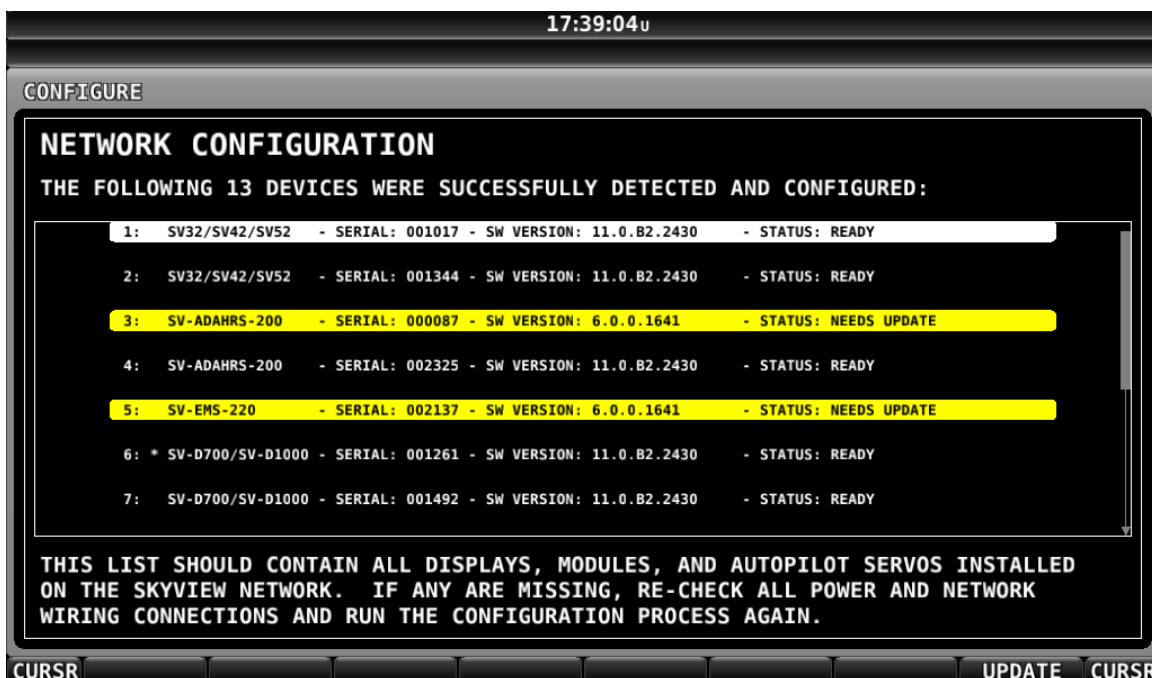

Figure 33: SkyView Network Configuration with Software Update

If you see a screen like the one above, simply press the button labeled UPDATE to update the software running on the equipment in the SkyView network.

To check on SkyView network status, enter the NETWORK STATUS... Menu in the Network Setup Menu (SETUP MENU > SYSTEM SETUP > SKYVIEW NETWORK SETUP > NETWORK STATUS...).

The Network Status Page shows all displays, modules, servos, and other Dynon Avionics products installed on the SkyView network via the D9 SkyView Network connectors. This includes the following devices: SV-HDX 800, SV-HDX1100, SV-ADAHRS-200/201 modules, SV-EMS-220 modules, SV-ARINC-429 modules, SV-COM-PANEL for SV-COM-X25/83 transceivers, SV-AP-PANEL / SV-KNOB-PANEL control panels, and Dynon Avionics Autopilot Servos. It does NOT include any non-Dynon Avionics devices or any of the following Dynon Avionics devices that connect via a method other than SkyView Network: SV-XPNDR-261 transponders, SV-ADSB-472 ADS-B receiver, SV-GPS-2020 GPS receiver, OAT(s), or individual engine sensors.

SkyView Network has redundancy and error detection features which allow it to detect and annunciate module and SkyView Network wiring faults. If SkyView reports a problem with an ADAHRS, EMS module, autopilot servo, or a problem with the "standby network", this NETWORK STATUS page will provide more information about the nature of the problem.

6.2.7 Ethernet Connection

SkyView systems containing more than one (1) display should ideally have their Ethernet ports connected for best operation. See Section 31 *Appendix C: Wiring and Electrical Connections* for further information about Ethernet.

6.2.8 Internal Time Keeping

Zulu/GMT time is initially obtained from a GPS source. Time is displayed as "--:--:--" until a GPS fix is received. When a display is turned off, a connected SV-BAT-320 backup battery enables the display to retain accurate time. To display time, a SkyView display that is not connected to an SV-BAT-320 must obtain a GPS fix each time it is powered on.

6.2.9 RS-232 Serial Devices

RS-232 serial communication to non-Dynon Avionics devices and interfacing of other devices in general can be involved and detailed. This installation manual is intended to provide general installation advice for the most common devices and situations.

A SkyView display includes five (5) general purpose RS-232 serial ports available for use with compatible equipment. Transmit (TX) and receive (RX) serial port wire sets are twisted together. Connected RS-232 serial devices must share a common power ground with the SkyView display(s).

Dynon Avionics devices that use RS-232 serial ports for communication include the SV-GPS-2020, SV-XPNDR-261, and SV-ADSB-472. Devices from other manufacturers that are commonly used with SkyView include transponders (with serial port inputs), NAV radios (such as Garmin SL30), COM radios (such as Garmin SL40), GPS devices (such as the Garmin X96 series), and Emergency Location Transmitters (ELTs). Reference the appropriate sections of this manual for detailed instructions for installing the SV-GPS-2020, SV-XPNDR-261, SV-ADSB-472, and Vertical Power VP-X. Additionally, an external serial device (such as a PC or external serial data logger) can be connected and used to record real-time ADAHRS and EMS data that can be output by SkyView.



Serial Port 5 is recommended for the SV-GPS-2020 connection. Its wire bundle includes serial transmit, receive, ground, and power, and its wires are color-matched to the wire colors on the SV-GPS-2020.

If you have more than one (1) SkyView display, each external serial device's serial TX wire needs to be connected to each screen so that it can send information to each display individually. Information that is received via serial connection is not automatically shared between multiple SkyView displays in an aircraft. Additionally, if the serial device you are connecting to your SkyView system can receive information from SkyView, that device's RX wire must be connected to all SkyView displays as well. SkyView has special hardware to allow multiple TX lines to be connected for redundancy. It is required that all connections to/from a particular serial device be connected to the same SkyView display serial port on every display in the SkyView system.

It is the installer's responsibility to determine how to connect external serial devices to the display using the included wire harness. Installers should reference serial device documentation for serial port specifications. The basic order for installing an external serial device is as follows.

1. Specify a serial port for the device.
2. Make the serial port electrical connection. If you have more than one (1) SkyView display, make the same connection to all SkyView displays.
3. Configure the serial port (under SETUP MENU > SYSTEM SETUP > SERIAL PORT SETUP) according to the device's documentation.
4. When the serial port configuration is complete, perform a final check by doing the following:
 - a. Power down all displays except #1. Verify all serial port devices are working - transponder, GPS, radios, etc.
 - b. Power down all displays except #2. Verify all serial port devices are working - transponder, GPS, radios, etc.
 - c. Power down all displays except #3. Verify all serial port devices are working - transponder, GPS, radios, etc.



A SkyView Display serial port can be configured to communicate with one (1) device on its TX and a different device on its RX, but when doing so, the TX and RX speeds must be the same.

Table 14: SkyView Serial Port Connections

Serial Port	Wire Function	SkyView Display Harness Wire Colors
1	TX	Brown with Orange stripe
	RX	Brown with Violet stripe
2	TX	Yellow with Orange stripe
	RX	Yellow with Violet stripe
3	TX	Green with Orange stripe
	RX	Green with Violet stripe
4	TX	Blue with Orange stripe
	RX	Blue with Violet stripe
5	TX	Gray with Orange stripe
	RX	Gray with Violet stripe
	SV-GPS-2020 Power	Solid Orange
	SV-GPS-2020 Ground	Solid Black

6.2.9.1 Traffic Devices

SkyView can receive and display aircraft traffic data from:

- Dynon Avionics SV-XPNDR-261 (from TIS).
- Dynon Avionics SV-ADSB-472 (from ADS-B).
- Garmin GTX 330 / 330ES (from TIS).
- Other devices that output traffic data that emulates "Garmin TIS format" including Garrecht / AIR Avionics TRX-1500 (set to TIS output), NavWorx ADS-B receiver, and Zaon XRX (set to "Garmin" output). For such devices, configure the SkyView serial port connected to these devices in SERIAL PORT x SETUP, SERIAL IN DEVICE to GARMIN TIS TRAFFIC (which will automatically set the associated parameters).

If a device that can provide traffic data is connected to SkyView and configured (usually as a TIS serial traffic device under SETUP MENU > SYSTEM SETUP > SERIAL PORT SETUP), further traffic display options can be configured in SETUP MENU > TRAFFIC SETUP. Display of traffic on the MAP page and the PFD page can be set to:

- NONE (Do not display traffic).
- TA ONLY (Display only Traffic Advisories (TAs)).
- ALL (Display ALL traffic).



Only one (1) device can provide traffic information to SkyView at any moment. If you have more than one (1) device connected to SkyView that can provide traffic (such as, but not limited to, SV-XPNDR-261 (TIS), SV-ADSB-472, etc.), the devices provide traffic information with the following priority, based on the completeness of the traffic portrait they provide:

1. SV-ADSB-472 with full traffic (ADS-B ground station reporting with radar coverage).
2. TIS transponder from SV-XPNDR-261 or Garmin GTX 330 / ES (when in an active TIS coverage area).
3. SV-ADSB-472 with No RADAR (ADS-B reception, but without ground ADS-B station coverage or radar target inclusion).

6.2.9.2 Dynon Avionics SV-XPNDR-261 Transponder

See the SV-XPNDR-261 Transponder section for detailed instructions on how to set up the serial connection to the SV-XPNDR-261.

Note that if you are using a Dynon Avionics SV-XPNDR-261 Transponder, none of the encoder options in the below sections should be set for the Dynon Avionics SV-XPNDR-261 module to receive pressure altitude. Instead, when the SV-XPNDR-261 is set up as described in the SV-XPNDR-261 Transponder section, it is automatically configured to receive pressure altitude from SkyView. Alternatively, systems that require the use of an external altitude encoder can be configured per the following section to have SkyView pass along an external pressure altitude source.

6.2.9.3 Dynon Avionics SV-ADSB-472

See Section 16 -SV-ADSB-472 ADS-B IN Receiver for detailed instructions on how to set up the serial connection to the SV-ADSB-472.

6.2.9.4 Garmin GTX 330ES

To enable ADS-B traffic with a Garmin GTX 330ES, both the transmit and receive serial ports between SkyView and the GTX 330ES must be connected and configured. The GTX 330ES must be fully configured to output ADS-B Out, which requires a TSO'd GPS position. Contact Garmin for correctly configuring the GTX 330ES ADS-B Out capability. Also see SV-ADSB-472 ADS-B IN Receiver, for additional configuration.

- SETUP MENU > SYSTEM SETUP > SERIAL PORT SETUP > SERIAL PORT x SETUP > SERIAL IN DEVICE > GARMIN GTX 330ES.
- SETUP MENU > SYSTEM SETUP > SERIAL PORT SETUP > SERIAL PORT x SETUP > SERIAL OUT DEVICE > ICARUS ALTITUDE 100ft OR ICARUS ALTITUDE 10ft.
- SETUP MENU > SYSTEM SETUP > AIRCRAFT INFORMATION > TRANSPONDER HEX CODE > (set to same HEX CODE as configured in the Garmin 330 ES) > ACCEPT (button).

6.2.9.5 External Serial Altitude Encoder Support

Some locales may require the use of a certified altitude encoder with the Dynon Avionics SV-XPNDR-261 Transponder. SkyView supports external serial altitude encoders that use Icarus/Garmin format. When one (1) is connected, the SV-XPNDR-261 uses the external altitude encoder data source instead of SkyView's own ADAHRS-generated pressure altitude. However, the altitude displayed by SkyView on the PFD page is ALWAYS sourced from SkyView ADAHRS data.

To have SkyView use an external altitude serial encoder as the pressure altitude source for the SV-XPNDR-261:

- Wire a SkyView serial receive line to the respective serial transmit connection from the serial altitude encoder. If you have more than one (1) SkyView display, make the same connection to all SkyView displays.
- Ensure there is a shared ground between the SkyView display and the serial altitude encoder. If you have more than one (1) SkyView display, make the same connection to all SkyView displays.
- Configure this serial port on each display under SETUP MENU > SYSTEM SETUP > SERIAL PORT SETUP. The SERIAL IN device for this serial port should be set to ICARUS/GARMIN ALTITUDE.

6.2.9.6 Non-Dynon Avionics Transponder Serial Altitude Encoder Output

To use SkyView's altitude output functionality with your transponder that can receive serial altitude input:

- Wire a SkyView serial transmit line to the respective receive connection on the transponder. If you have more than one (1) SkyView display, make the same connection to all SkyView displays.
- Ensure there is a shared ground between the SkyView display and the transponder. If you have more than one (1) SkyView display, make the same connection to all SkyView displays.
- Configure the serial port on each display appropriately. There is an example serial port configuration on Page 81.

6.2.9.7 SkyView Altitude Encoder Output Formats



There must be a SkyView ADAHRS installed for the altitude encoder output to function.

SkyView outputs its altitude measurements in two different formats. You can use either format on any of the serial ports. These formats are described in Table 15: Icarus Format.

Table 15: Icarus Format

ICARUS	
Used by	Garmin GTX330/ES (Garmin serial port must be set to Icarus input), Garmin GTX327 (Garmin serial port must be set to Icarus input), Garmin GTX328 (Garmin serial port must be set to Icarus input), Icarus, Trimble
Baud rate	9600
Format	ALT, space, five (5) altitude bytes, carriage return
Example message	ALT 05200[CR]

6.2.9.8 Non-Dynon Avionics Transponder

SkyView can display the status of the Garmin GTX 327 and Garmin GTX 330 / 330ES transponders. To use this functionality with SkyView:

- Wire a serial receive line to the respective transmit line on the transponder. If you have more than one (1) SkyView display, make the same connection to all SkyView displays.
- Ensure there is a shared ground between the SkyView display and the transponder. If you have more than one (1) SkyView display, make the same connection to all SkyView displays.
- Configure the serial port on each display appropriately under **SETUP MENU > SYSTEM SETUP > SERIAL PORT SETUP**.

- Configure the serial port on the transponder appropriately. For a Garmin GTX 327, 330 / ES, the RS-232 output of the appropriate serial port on the transponder should be set to REMOTE+TIS.

6.2.9.9 Garmin SL30 COM / NAV Radio

In addition to the NAV radio functions of the SL30, SkyView can display COM radio information from the SL30 on the top bar of the SkyView display(s) and send COM frequencies to the SL30 (TUNE COM).

- Connect SL30 serial RX pin 4 (RxD1) to a SkyView serial TX. If you have more than one (1) SkyView display, make the same connection to all SkyView displays.
- Connect SL30 serial TX pin 5 (TxD1) to a SkyView serial RX. If you have more than one (1) SkyView display, make the same connection to all SkyView displays.
- Ensure there is a shared ground between the SkyView display and the SL30. If you have more than one (1) SkyView display, make the same connection to all SkyView displays.
- Configure the serial port on the SL30 appropriately. On the SL30, the Indicator Head Type should be set to NONE.

On SkyView

- SETUP MENU > SYSTEM SETUP > SERIAL PORT SETUP > SERIAL PORT x SETUP > SERIAL IN DEVICE > GARMIN / APOLLO SL30. This will automatically set the SERIAL IN/OUT BAUD RATE and SERIAL OUT DEVICE.
- Set SERIAL IN FUNCTION TO NAV 1, 2, 3, or 4. If the SL30 is the only NAV device, select NAV 1.
- Set NAVIGATION SOURCE DISPLAY NAME: (user selectable, 7 characters, suggest SL30). The name entered here is displayed as the HSI source and the Flight Plan Source (if this device outputs a flight plan).
- If you wish the SL30 frequency and status to be displayed on the top bar: SETUP MENU > SYSTEM SETUP > DISPLAYED COM > GARMIN / APOLLO SL30 (PORT x) and SETUP MENU > SYSTEM SETUP > DISPLAY COM IN TOP BAR: YES

6.2.9.10 Garmin SL40 COM Radio

SkyView can display COM radio information from the SL40 on the SkyView top bar and send COM frequencies to the SL40 (TUNE COM).

- Connect SL40 serial RX pin 10 (RxD1) to a SkyView serial TX. If you have more than one (1) SkyView display, make the same connection to all SkyView displays.
- Connect SL40 serial TX pin 3 (TxD1) to one (1) of the SkyView serial RX pins on each display. If you have more than one (1) SkyView display, make the same connection to all SkyView displays.
- Ensure there is a shared ground between the SkyView display, and the SL40. If you have more than one (1) SkyView display, make the same connection to all SkyView displays.

- Configure the serial port on the SL40 appropriately.
- Configure the serial port: SETUP MENU > SYSTEM SETUP > SERIAL PORT SETUP > SERIAL PORT x SETUP > SERIAL IN DEVICE > GARMIN / APOLLO SL40. This will automatically set the SERIAL IN FUNCTION, SERIAL IN/OUT BAUD RATE, and SERIAL OUT DEVICE.
- Set the SL40 status to be displayed on the top bar: SETUP > SYSTEM SETUP > DISPLAYED COM > GARMIN / APOLLO SL40 (PORT x) and SETUP MENU > SYSTEM SETUP > DISPLAY COM IN TOP BAR: YES.

6.2.9.11 Trig TY91 COM Radio

SkyView can display COM radio information from the TY91 on the top bar of the SkyView display(s) and "push" COM frequencies to the TY91 (TUNE COM).

- Connect TY91 RS232 in (TC90 Pin 6) to a SkyView serial TX. If you have more than one (1) SkyView display, make the same connection to all SkyView displays.
- Connect TY91 RS232 Out (TC90 Pin 5) to a SkyView serial RX. If you have more than one (1) SkyView display, make the same connection to all SkyView displays.
- Ensure there is a shared ground between the SkyView display and the TY91. If you have more than one (1) SkyView display, make the same connection to all SkyView displays.
- On the TY91, configure the serial port appropriately (per Trig's documentation).

On SkyView

- SETUP MENU > SYSTEM SETUP > SERIAL PORT SETUP > SERIAL PORT x SETUP > SERIAL IN DEVICE > TRIG TY91. This will automatically set the SERIAL IN FUNCTION, SERIAL IN/OUT BAUD RATE, and SERIAL OUT DEVICE.
- SETUP MENU > SYSTEM SETUP > PRIMARY COM > TRIG TY91 (PORT x).
- SETUP MENU > SYSTEM SETUP > DISPLAY COM IN TOP BAR > YES.

6.2.9.12 Icom IC-A210 TSO COM Radio

The IC-A210 does not transmit status or frequencies via serial port, so IC-A210 information cannot be displayed on the top bar of the SkyView display(s). SkyView can send COM radio frequencies to the IC-A210 (TUNE COM).

- Confirm that your A210 is running Software version 1.53 or newer. This feature will not work with old Software. Contact Icom for details on upgrading your radio Software.
- Connect IC-A210 serial RX (Molex Pin 2 / D15 Pin 10) to a SkyView serial TX. If you have more than one (1) SkyView display, make the same connection to all SkyView displays.
- Ensure there is a shared ground between the SkyView display and the IC-A210. If you have more than one (1) SkyView display, make the same connection to all SkyView displays.
- On the IC-A210, configure the serial port appropriately (per Icom documentation).

On SkyView

- SETUP MENU > SYSTEM SETUP > SERIAL PORT SETUP > SERIAL PORT x SETUP > SERIAL IN DEVICE > ICOM A210. This will automatically set the SERIAL IN FUNCTION, SERIAL IN/OUT BAUD RATE, and SERIAL OUT DEVICE. (Although there is no IC-A210 serial TX to SkyView serial RX connection, SERIAL IN DEVICE must be configured as described.).
- SETUP MENU > SYSTEM SETUP > PRIMARY COM > ICOM A210 (PORT x) and SETUP MENU > SYSTEM SETUP > DISPLAY COM IN TOP BAR > NO.

6.2.9.13 Garmin GTR 200, GTR 225 COM Radio, GNC 255 COM Radio / NAV Receiver

SkyView can send frequencies to the GNC 255's standby frequency.

On the GNC 255:

- Connect GNC 255 P2001 Pin 16 to a SkyView serial TX. If you have more than one (1) SkyView display, make the same connection to all SkyView displays.
- Connect GNC 255 P2001 Pin 1 to a SkyView serial RX. If you have more than one (1) SkyView display, make the same connection to all SkyView displays.
- Ensure there is a shared ground between the SkyView display and the GNC 255. If you have more than one (1) SkyView display, make the same connection to all SkyView displays.
- On the GNC 255, configure the serial port:
 - Set "I/O Mode" to "NMEA."
 - Set "CDI Indicator" to "NONE."

On SkyView:

- SETUP MENU > SYSTEM SETUP > SERIAL PORT SETUP > SERIAL PORT x SETUP > SERIAL IN DEVICE > GARMIN GNC 255 A/B. This will automatically set the SERIAL IN/OUT BAUD RATE, and SERIAL OUT DEVICE.
- SETUP MENU > SYSTEM SETUP > SERIAL PORT SETUP > SERIAL PORT x SETUP > SERIAL IN FUNCTION > NAV 1.

6.2.9.14 Trig Avionics TY91 and TY92 COM Radio

SkyView can display COM radio information from the ATR833, GTR 200, GTR 225, GNC 255, and TY91/92¹ on the SkyView top bar and send COM frequencies to them (TUNE COM).

Note that SkyView does not send database information for the GTR 200 to enable the GTR 200's "Nearest or Flight Plan Airports" feature.

- Connect the radio's serial RX to a SkyView serial TX. If you have more than one (1) SkyView display, make the same connection to all SkyView displays.

¹ Full TY91/92 8.33 kHz support depends on a future software update from Trig.

- Connect the radio's serial TX to one (1) of the SkyView serial RX pins on each display. If you have more than one (1) SkyView display, make the same connection to all SkyView displays.
- Ensure there is a shared ground between the SkyView display, and the radio. If you have more than one (1) SkyView display, make the same connection to all SkyView displays.
- Configure the serial port on the radio appropriately.
- Configure the serial port: SETUP MENU > SYSTEM SETUP > SERIAL PORT SETUP > SERIAL PORT x SETUP > SERIAL IN DEVICE >
FUNKE ATR833 or
GARMIN GTR 200 or
GARMIN GNC 255 A/B or
GARMIN GTR 225 A/B or
TRIG TY9X 25KHz ONLY
TRIG TY9X 8.33/25KHz
 - This configuration will automatically set the SERIAL IN FUNCTION, SERIAL IN/OUT BAUD RATE, and SERIAL OUT DEVICE.
- Set the radio status to be displayed on the top bar: SETUP > SYSTEM SETUP > DISPLAYED COM > (device you chose above) (PORT x) and SETUP MENU > SYSTEM SETUP > DISPLAY COM IN TOP BAR: YES

6.2.9.15 Emergency Location Transmitter (ELT)

SkyView can provide a GPS data stream to ELTs that accept GPS data in NMEA format.

- Wire a serial transmit (TX) line from one (1) display to the receive (RX) line on the ELT. If you have more than one (1) SkyView display, make the same connection to all SkyView displays.
- Ensure there is a shared ground between the SkyView display and the ELT. If you have more than one (1) SkyView display, make the same connection to all SkyView displays.
- Configure the SkyView display serial port:
 - SETUP MENU > SYSTEM SETUP > SERIAL PORT SETUP > SERIAL PORT x SETUP.
 - SERIAL IN DEVICE: (don't care, does not affect ELT).
 - SERIAL IN/OUT BAUD RATE: (set to match speed of ELT; typically 4800 or 9600).
 - SERIAL OUT DEVICE: NMEA OUT (BASIC).

6.2.9.16 Dynon Avionics ADAHRS / EMS / SYSTEM / NMEA (GPS) Data Outputs

To output real-time data to an external serial device, such as a serial data logger or other device that accepts NMEA or Dynon Avionics formats:

- Wire a serial transmit line from one (1) display to the receive line on the external serial device. If you have more than one (1) SkyView display, make the same connection to all SkyView displays.
- Ensure there is a shared ground between the SkyView display and the external serial device. If you have more than one (1) SkyView display, make the same connection to all SkyView displays.
- Configure the serial port on the display appropriately under SETUP MENU > SYSTEM SETUP > SERIAL PORT SETUP, SERIAL PORT x SETUP > selecting the desired output data format.

6.2.9.17 TIS Format Traffic Output

SkyView can be configured to output TIS format traffic information for external display on other avionics that can receive traffic in TIS format. When this option is selected, only the actual TIS traffic from an SV-XPDR-261 is included in this serial data stream. This stream does not include ADS-B, FLARM, Zaon, or other traffic sources that may be available to SkyView.

- Wire a serial transmit line from one (1) display to the receive line on the external serial device. If you have more than one (1) SkyView display, make the same connection to all SkyView displays.
- Ensure there is a shared ground between the SkyView display and the external serial device. If you have more than one (1) SkyView display, make the same connection to all SkyView displays.
- Configure the serial port on the display appropriately under SETUP MENU > SYSTEM SETUP > SERIAL PORT SETUP, SERIAL PORT X SETUP > TIS OUT (330 FORMAT).

6.2.10 USB Usage and Accessibility



It is useful to have the USB socket on the display's wire harness accessible after installation for file uploads and downloads.

The USB connector is used during the following operations:

- System Software updates.
- Configuration file uploads and downloads.
- Database updates.

6.2.11 External Dim Control (Dimming) Connections

DIM INPUT (Pin 25) The backlight level on a SkyView display can be increased or decreased using a varying DC voltage of 0 to 36 volts DC. See External Brightness Management later in this section to configure brightness levels for specific voltages.

DIM OUTPUT (Pin 26) The DIM OUTPUT signal is an approx. 120 Hz (this may change in future Software revisions) Pulse Width Modulation (PWM) signal directly proportional to the screen brightness – 100% to 0.02%. This output is designed to directly control the dim level of devices such as LEDs; a common use is for the back-lighting of switches in a panel so that they dim at night in conjunction with SkyView’s automatic dim levels.

The DIM OUTPUT (Pin 26) signal is an open collector to ground – it acts as a switch to ground and does not source any power itself. Pin 26 can sink a maximum current of 120mA and a maximum voltage of 40V. The DIM OUTPUT signal is not analog and cannot be used to control the dim level of devices that expect 0-5V, 0-12V, or a resistance as their dimming input.

Do not connect the DIM OUTPUT (Pin 26) signal from multiple SkyView screens in parallel. The DIM OUTPUT signals from each display are not synchronous, and this will lead to inconsistent behavior.

6.2.11.1 Audio Output Electrical Connections



Dynon Avionics recommends that SkyView’s audio outputs be connected to an unmuted input on your audio panel. When connected this way, critical audio alerts generated by SkyView are not muted by ATC transmissions or other audio events that could cause SkyView’s audio to be suppressed if it were connected to a muting input.



SkyView’s audio output cannot be connected in parallel with a radio to a headset. Doing so will significantly reduce the volume of the radio output, possibly to the level that it is not usable. An audio mixer or audio panel is required to utilize this output.

The audio outputs on pins 13 and 31 (left and right, respectively) of the display’s D37 connector can drive audio panel auxiliary inputs. When interfaced with such devices, they can generally be used with any input designated as an auxiliary input without any external resistors or other components required.

Use left and right audio outputs for stereo mode. If the audio panel only supports mono input, short the left and right audio outputs together and connect them to the mono input on the device. To minimize noise, ensure that your SkyView audio ground and audio panel ground is *directly connected together*, even though they nominally share a common ground via other aircraft wiring (audio ground is pin 30 on the D37).

If there is more than one display on a SkyView network, you **MUST** connect all displays’ audio outputs to the same audio panel input to ensure that audio is always heard. Electrically short the respective left and right outputs together for stereo mode (i.e., left-to-left and right-to-right) or connect all audio outputs together for mono mode. The same rule applies for audio grounds.



To minimize the possibility of audio "humming", a 16 AWG wire may optionally be connected between the ground point for the audio panel/radio(s) and SkyView display case(s). To attach the wire to the rear of the SkyView display, a 4-40 x 3/16" long screw may be screwed into the threaded boss above the USB ports on the back of the SkyView display.

Audio output volume will be controlled via the interface on a SkyView display, so no external hardware components are required. The audio output from SkyView has a maximum output of 10V p-p with 50 Ω (50 ohms) of source impedance.

SkyView systems with more than one display normally only output audio alerts from one display to minimize audio distortion. In a SkyView system that has more than one display and dual SV-EMS-220s to monitor dual engines, EMS audio alerts are enabled from two displays. At moments when two displays are outputting EMS audio alerts, there may be minor "doubling" of audio alerts heard in the audio system.

6.2.11.2 SkyView Audio Output Settings

Go to SETUP MENU > SYSTEM SETUP > AUDIO SETUP to configure audio output settings. Most of the items in this menu control whether the audio output for a particular alert or alert category is played or not. The settings that can be adjusted here that are not voice alert toggles are:

- VOLUME CONTROL / TEST – Sets the volume level. While in this menu, sound is played continuously so that proper audio connectivity and volume levels can be confirmed.
 - In this menu only, audio is only outputted from the actual display that is in the setup menu. This allows one (1) to troubleshoot the physical audio connections. In actual operation, only one (1) of the displays transmits audio at a time. Which display happens to be transmitting is automatically managed by SkyView. Since all displays' audio outputs are connected together (and to the or audio panel), this is transparent in actual use.
- BOOT SOUND – When set to ON, the system will say "Dynon Avionics SkyView" when it first starts up.
- ANGLE OF ATTACK – This sets a pulsing, progressive tone that increases in frequency, similar in nature to a conventional reed type aircraft stall warning sound to a reed-type stall warning sound, although it is much more predictable in its progression. It can be set to start its pulsing tones at either the border of the yellow/green marks on the AOA bars, the middle of the yellow, or the yellow/red border. The pulsing tones start at the level selected and get progressively quicker and closer together until a solid tone is played at critical AOA (in the red).
 - INHIBIT AOA BELOW AIRSPEED – Allows you to set an airspeed below which no AOA tones are played. This helps prevent nuisance alarms while on the ground and taxiing, especially in taildraggers.

6.2.12 Contact Inputs

Contact Input #1 – (Optional) External LEVEL Button. See the Autopilot section for detailed explanation.

Contact Input #2 – (Optional) External GO AROUND Button. See the Autopilot section for detailed explanation.

Contact Input #3 and #4 are currently not supported. A future Software update may enable this functionality. Do not connect anything to these pins currently.

6.2.13 Reserved Connections for Future Use

Do not connect anything to unspecified D37 connector pins (directly or using the display harness). These pins are reserved for future use.

6.3 Required Display Configuration

Each SkyView display installed in the instrument panel must be configured as detailed in the section.



For certification and to ensure airworthiness, primary and secondary displays must be configured following the instructions in this section.

6.3.1 Primary Display

A SkyView HDX System must have one display configured as the Primary Display. This display should be located at the position where the pilot would normally fly the aircraft. For airplanes, this is typically the left side.

To configure a display as Primary, enter the SCREEN LAYOUT SETUP menu (SETUP MENU > SYSTEM SETUP > SCREEN LAYOUT SETUP...) and configure the menus as shown in Figure 34 and described below:

1. Set REVERSION MODE ENABLED to YES
2. Set THIS SCREEN ROLE to PFD.

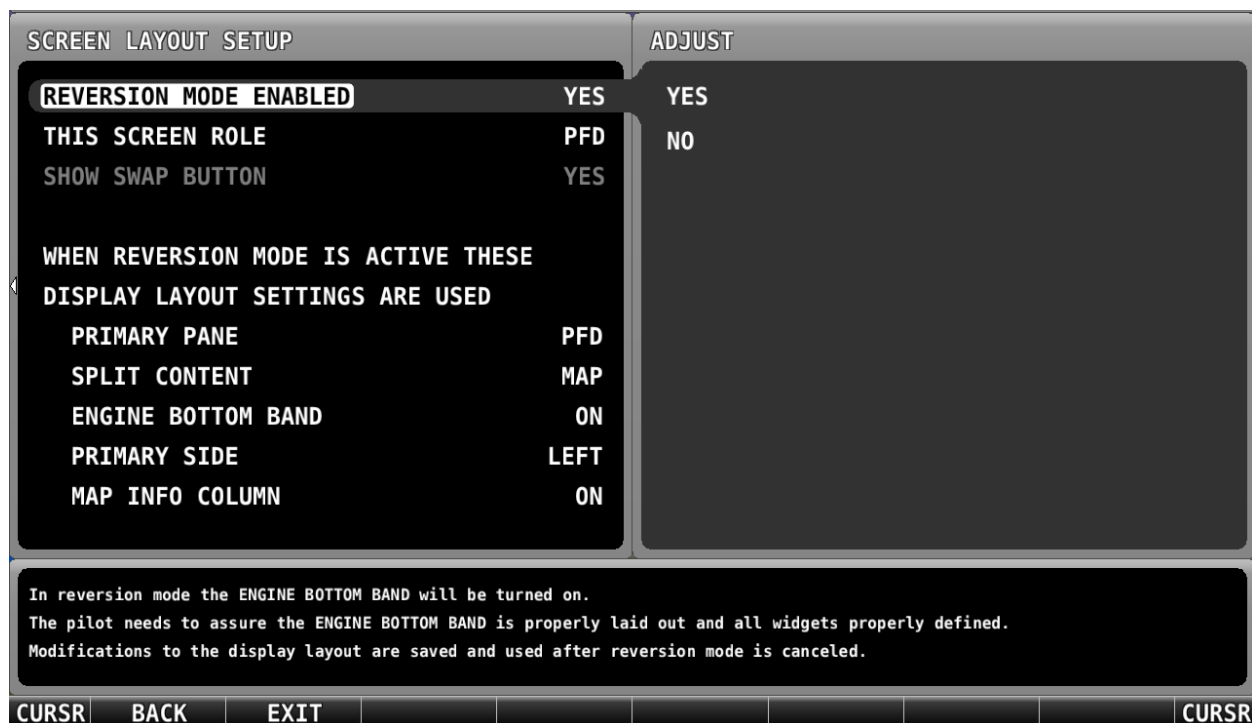

Figure 34: Configuring a Primary Display

6.3.2 Secondary Displays

A SkyView HDX System may have up to two additional displays configured as Secondary Displays. These screens can be located anywhere on the instrument panel, such as the co-pilot's side. For airplanes, this is typically the right side.

To configure a display as Secondary, enter the SCREEN LAYOUT SETUP menu (SETUP MENU > SYSTEM SETUP > SCREEN LAYOUT SETUP...) and configure the menus as shown in Figure 35 and described below:

1. Set REVERSION MODE ENABLED to YES
2. Set THIS SCREEN ROLE to UNRESRICTED



Figure 35: Configuring a Secondary Display

6.3.2.1 EMS Display for Twin-Engine Airplanes

Twin-engine airplanes equipped with SkyView Engine Monitoring System must have a secondary displayed designated to always present EMS information.

To configure a display as EMS, enter the SCREEN LAYOUT SETUP menu (SETUP MENU > SYSTEM SETUP > SCREEN LAYOUT SETUP...) and configure the menu as described below:

1. Set REVERSION MODE ENABLED to YES
2. Set THIS SCREEN ROLE to EMS

6.4 Other Display Configuration

You can access important information about a SkyView display, as well as configure serial ports, characterize your display backlight behavior, and specify other display-specific settings.

6.4.1 How to Access Display Hardware Information

Enter the Display Hardware Information Page (SETUP MENU > LOCAL DISPLAY SETUP > DISPLAY HARDWARE INFORMATION) to access important display hardware information. This menu contains status information only – nothing on it is configurable. Reference the Operation Section of this manual for more information about this menu.

6.4.2 Serial Port Configuration



Reference serial device documentation for serial communication specifications.

SkyView serial ports are configured in the Serial Port Setup Menu (SETUP MENU > SYSTEM SETUP > SERIAL PORT SETUP). SkyView serial ports have four (4) parameters that must be defined:

- Input Device.
- Input Function.
- Baud Rate.
- Output Device.



Note that sometimes a parameter will be defined as NONE on the screen. For example, when a serial port is configured as only an output, the input device and input function will both be set to NONE.

6.4.2.1 Input Device

Set the input device to the data format the SkyView display should expect from an input device. The configurable options list contains equipment by brand and model and generic data formats such as NMEA and aviation. NMEA is the standard format for most GPS units the SV-GPS-2020). Aviation is used by some Garmin and Bendix/King panel mount equipment. *If your specific equipment is listed by brand and model, we recommend you configure SkyView to use this option instead of a generic data format.*

If you have any ARINC-429 devices, these are configured separately. See Section 15 *SV-ARINC-429 ARINC Module* for more information.

6.4.2.2 Input Function

SkyView has several options for input functions: NONE, GPS, NAV, or POS. Set the device's input function to NONE if it does not have an input function.

- **GPS devices** provide GPS position and navigational information. These devices are generally "moving maps" that depict airports, airspaces, etc., and can generate flight plans. They provide source data for the moving map, HSI, autopilot, synthetic vision, and the clock in the Top Bar. An example GPS device is a Garmin X96.
- **NAV devices** provide radio-based navigational information from a VOR or ILS. They provide source data for the HSI and autopilot.
- **POS devices** provide positional information only. These are generally simple GPS receivers that cannot do flight planning. They provide source data for the moving map, synthetic vision, and the clock in the Top Bar. *Note that a POS device does not provide any data for the HSI and will not appear in the HSI NAVSRC rotation.* An example of a POS device is the Dynon Avionics SV-GPS-2020.

6.4.2.3 Input Function Considerations and Priorities

SkyView's Moving Map Page uses POS and GPS sources for its data. Regardless of the number of data sources in your system, this page prioritizes these sources and fails over to them as follows:

POS 1 ▶ GPS 1 ▶ GPS 2 ▶ GPS 3 ▶ GPS 4 ▶ POS 2 ▶ POS 3 ▶ POS 4

For example, if your system has one (1) SV-GPS-2020 configured as POS 1 and a Garmin 396 configured as GPS 1, the Moving Map will always use the SV-GPS-2020 as its primary data source. If the SV-GPS-2020 fails or you configure its input function to NONE, the Moving Map Page will use the Garmin 396 (or other GPS source) configured as GPS 1 as its primary data source.

The SkyView HSI uses GPS and NAV sources for its overlays and the user must choose the source during operation.



SkyView's internal Navigation Mapping System can generate navigation information which can be displayed on the HSI. The Navigation Mapping System requires GPS data, which is sourced from the active (highest priority in the above list) POS or GPS source. Regardless of what source is being used for position information, the navigation provided by the Navigation Mapping System is always the SKYVIEW source on the HSI.

6.4.2.4 Baud Rate

Set this to match the baud rate of the serial device that is connected to the serial port. SkyView supports the following baud rates: 1200, 2400, 4800, 9600, 19200, 38400, 57600, and 115,200.

Note that if you use a serial port for a split function (e.g., GPS in and altitude encoder out), the input and output devices must use the same baud rate.

6.4.2.5 Output Device

Set output device to the data format the serial device should expect from the SkyView display (e.g., ICARUS (10ft)).

6.4.2.6 Example SkyView Serial Port Configuration for Icarus-Compatible Transponder

This example assumes that an Icarus format compatible transponder has been installed on serial port 1.

1. Enter the Serial Port 1 Setup Menu (SETUP MENU > SYSTEM SETUP > SERIAL PORT SETUP > SERIAL PORT 1 SETUP).
2. Set serial 1 input device to NONE (SERIAL 1 IN DEVICE: NONE).
3. Set serial 1 in function to NONE (SERIAL 1 IN FUNCTION: NONE).
4. Set serial 1 baud rate to 9600 (SERIAL 1 IN/OUT BAUD RATE: 9600)
5. Set serial 1 output device to ICARUS (100ft) or ICARUS (10ft) (SERIAL 1 OUT DEVICE: ICARUS (100ft) or ICARUS (10ft).
6. Press BACK or EXIT to save the settings.

6.4.3 Brightness Setup

Enter the Brightness Setup Page (SETUP MENU > LOCAL DISPLAY SETUP > BRIGHTNESS SETUP) to characterize the display's backlight behavior. The backlight level can be adjusted manually by the user automatically by the display based on ambient light conditions, or by an external control signal while on the Brightness Setup Page and in normal flight. *Regardless of the specified control method, users always have the option to manually adjust the backlight level in the Dim Menu.*

6.4.3.1 Automatic Brightness Management

To set the backlight level so that it automatically adjusts, set BRIGHTNESS SOURCE to INTERNAL (ZERO OFFSET) or INTERNAL (LAST) depending on whether you want the brightness setting to reset when SkyView is started, or you want the brightness setting from SkyView's last use to be used when SkyView is started. When this option is selected, dimming is normally controlled automatically via ambient light detection, but it can also be controlled manually by using the DIM Menu. Dynon Avionics has created a default dimming profile that should work well in most aircraft. If you find that this profile does not work well in your installation, it can be customized to suit your preferences using the tools on the BRIGHTNESS SETUP Menu. This menu displays several parameters, which are listed and briefly explained below:

- LOCAL BRIGHTNESS SENSOR – This is an integer value ranging from 0 to 999 that represents the amount of light sensed by the display's integrated light sensor. Use this value to characterize the ambient light levels in your installation during characterization.
- BRIGHTNESS TARGET – This is a percentage ranging from 0% to 100% that represents the calculated target backlight level based on the sensed ambient light level and the percent brightness sensor value map. *The actual brightness never drops below 20% when the Brightness Setup Page is displayed, even though the target value may be below 20%.*

- XX% Brightness Sensor Value – There are four (4) brightness sensor values: 25%, 50%, 75% and 100%. These values are correlated to a user-specified brightness sensor value, which are to the right of the percent value. These percentages along with the minimum brightness sensor value (explained below) form the calibration points for the backlight management profile. When the current brightness sensor value matches one (1) of these points, the target backlight level is adjusted to its matching percentage. When the current brightness sensor value is in between these points, the display interpolates between the points and calculates an appropriate target backlight level. These values must be set by the user.
- MINIMUM BRIGHTNESS SENSOR VALUE – This is an integer value ranging from 0 to 999 that represents the smallest amount of light that is expected to be sensed by the integrated light sensor. This must be set by the user.
- RESET TO DYNON AVIONICS DEFAULTS – (If needed) Use this option to start over.

Press the ACCEPT button to save any changes you make.

6.4.3.2 External Brightness Management

The brightness level of SkyView and Dynon Avionics panel units can be increased or decreased by applying 0 to 36 volts DC to a SkyView display's DIM INPUT (Pin 25). Dynon Avionics offers the SV-KNOB-DIMMER (P/N 102801-000) as a convenient way to use this feature.

6.4.4 Top Bar Setup

The top bar is the strip across the top of the screen. It displays textual information such as the clock, autopilot status, transponder, and COM radio status.

Enter the Top Bar Setup Page to configure the top bar (SETUP MENU > LOCAL DISPLAY SETUP > TOP BAR SETUP).

6.4.5 Aircraft Information

Use the Aircraft Information Page (SETUP MENU > SYSTEM SETUP > AIRCRAFT INFORMATION) to record important information about your aircraft.



The tail number must be present for SkyView network configuration and operation.

If you have more than one display in your SkyView system, the tail number only needs to be set on the display that you initially perform the Network Configuration on. At network configuration time, all other displays that are set to the default tail number of DYNON will automatically have their settings and tail number synchronized with the display the configuration is performed from. After configuration, all displays' tail numbers and settings will be synchronized, and further setup tasks can be performed from any display.



For US registered aircraft with a conventional (pattern) N-number, when the tail number is entered, the HEX CODE will be set automatically (computed based on the aircraft N-number). If the TRANSPONDER HEX CODE cannot be computed, the TRANSPONDER HEX CODE remains set to 000000.

6.4.6 Master Volume Audio Setting

The master audio volume for the SkyView HDX needs to be set at a level that can be clearly heard in the cockpit when the engine(s) is running, but not at a level that causes system overload or crew discomfort.

Set master to volume to 100%, and then test volume level with engine(s) running. Reduce volume level and re-test as needed until suitable volume level is achieved.

- SETUP MENU > SYSTEM SETP > AUDIO SETUP > MASTER VOLUME CONTROL / TEST

6.4.7 SkyView HDX Display Setup / Layout

For SkyView HDX, setup / layout of the display / screen is performed as an operational function by pushing the DISPLAY key in the Main Menu.

Reference for the SkyView HDX Pilot's User Guide for more detail about setting up your SkyView HDX display's layout.

6.4.8 SkyView HDX Touch Setup

SkyView HDX displays SV-HDX800 and SV-HDX1100 have settings that are specific to the touch interface: SETUP MENU > LOCAL DISPLAY SETUP > TOUCH SETUP.

- SHOW TOUCHES – YES/NO – Enables / disables a small circle to appear on the touch screen showing where the touch screen is sensing finger(s). SHOW TOUCHES is primarily used for diagnostics / troubleshooting and is not normally enabled.
- HARDWARE STATUS, EVENT COUNTER, POINT #1, POINT #2, and TOUCH TEST... are used for diagnostics / troubleshooting of the touch system of the display.

6.4.9 Glide Ring Setup

SkyView HDX, can display a Glide Ring. For instructions on how to use the Glide Ring feature, see the SkyView HDX Pilot's User Guide.

There are two (2) settings that need to be adjusted for your specific aircraft for Glide Ring to be accurately displayed:

- SETUP MENU > AIRCRAFT INFORMATION > SINK RATE DURING GLIDE
- SETUP MENU > PFD SETUP > AIRSPEED LIMITATIONS > Vg – BEST GLIDE (under PERFORMANCE)

6.4.10 Weight and Balance Setup

SkyView HDX can assist you in computing Weight and Balance for your aircraft.

At least two (2) weight / moment points are required to define the quadrilateral that defines your Center of Gravity (CG) operating limits and the weight / moment points of the stations (which you define).

After setup is complete, Weight and Balance is accessed from the MENU > WEIGHT BAL icon (SkyView HDX). For instructions on how to use the Weight and Balance feature, see the SkyView HDX Pilot's User Guide.

For Weight and Balance calculations to be displayed, several settings must be entered for your specific aircraft:

- SETUP MENU > AIRCRAFT INFORMATION > WEIGHT & BALANCE
 - > MAX GROSS WEIGHT
 - > EMPTY WEIGHT
 - > EMPTY ARM
 - > EMPTY MOMENT
 - > STATIONS
 - At least one (1) Station is required. Up to nine (9) Stations can be defined.
 - Typically, Stations would be defined for Fuel, Pilot, Co-pilot, and Baggage
 - Each Station entry consists of:
 - > NAME
 - > MAX Weight
 - > ARM
 - > ENTER AS FUEL (Y/N)
 - > CG LIMITS
 - A minimum of two (2) CG Limits is required. Typically, enter a CG limit for the forward maximum CG points and a CG limit for the aft maximum CG point. More complicated limits for different weights (such as with a C172) can be accommodated.
 - > WEIGHT
 - > ARM

6.4.11 Maintenance Log Setup

SkyView HDX can provide up to 10 maintenance reminders based on date, elapsed tach time, or elapsed Hobbs Time. A maintenance reminder can also be displayed with no time basis (display text only).

After setup is complete, the Maintenance Log is accessed from the MENU > MAINT LOG icon. For instructions on how to use the Maintenance Log feature, see the SkyView HDX Pilot's User Guide.

Each item in the maintenance log requires entry of the time basis (or NONE) to determine whether the item is not yet due, due, or overdue.

- SETUP MENU > AIRCRAFT INFORMATION > MAINTENANCE LOG
 - > LOG ITEM x
 - > NAME (user-defined text, up to 14 characters)
 - > TIME BASIS (NONE | DATE | TACH | HOBBS)
 - > END TIME, HRS (if TACH or HOBBS was selected)
 - or...
 - > END DAY, END MONTH, END YE
 - AR (if DATE was selected)

7 SV-KNOB-PANEL Control Panel

This section contains pre-installation considerations and installation instructions and details to install the SV-KNOB-PANEL/H (Horizontal orientation) and SV-KNOB-PANEL/V (Vertical orientation). Physically, electronically, and operationally, the two (2) versions are identical, and hereafter referred to SV-KNOB-PANEL.

SV-KNOB-PANEL is an optional control panel for a SkyView system that provides dedicated function knobs for:

- ALT
- BARO
- HDG/TRK

that are otherwise operated from the multifunction knobs on a SkyView display(s). Each SV-KNOB-PANEL knob can be pressed to sync each bug/setting, the same as using the knobs on the SkyView display. When an SV-KNOB-PANEL is installed in a SkyView system, the knobs on a SkyView display can still be set to ALT, BARO, and HDG/TRK if desired. Up to two (2) SV-KNOB-PANELS can be installed in a SkyView system.

7.1 Mechanical Installation

The following diagram shows the mounting dimensions of the SV-KNOB-PANEL.

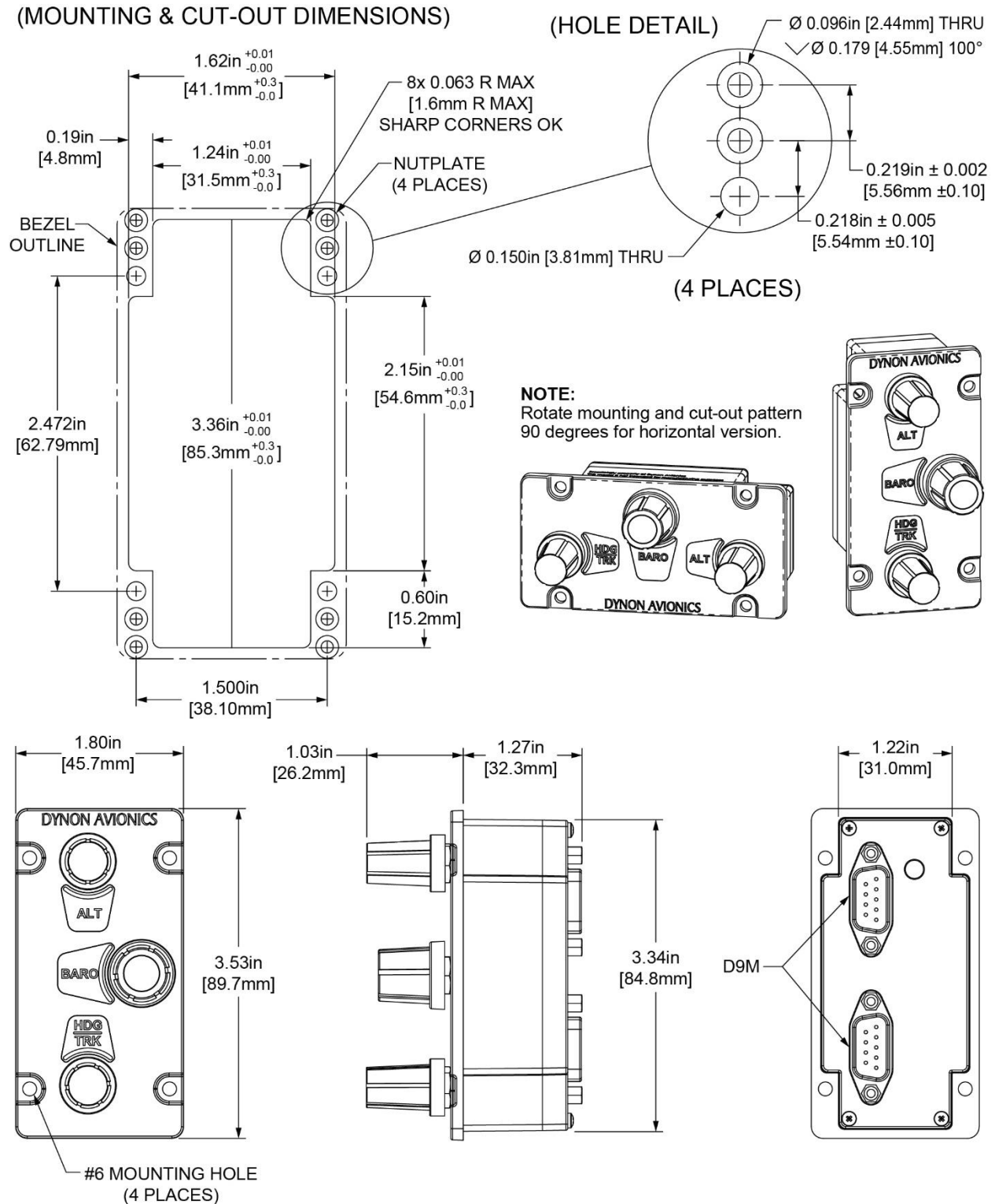

Figure 36: SV-KNOB-PANEL Panel Cutout and Mounting Hole Dimensions

7.2 Electrical Installation

SkyView Network

The SV-KNOB-PANEL has two (2) SkyView Network connections (D9 connectors). Both connectors are electrically identical and are internally connected. Thus, the SV-KNOB-PANEL can be installed in the SkyView Network as a "pass-through" device, or "daisy chained" from one (1) SkyView Network device, through the SV-KNOB-PANEL, to the next SkyView Network device. The SV-NET-1.5CC is an 18-inch (45.72 cm) SkyView Network cable that is ideal for such situations. The SV-AP-PANEL receives power (for operation of the buttons) from SkyView Network. Backlighting of the SV-KNOB-PANEL is controlled by the SkyView display(s).

7.2.1 Network Setup

As with all other SkyView Network devices, the SV-KNOB-PANEL must be configured into the SkyView Network:

- Go to SETUP MENU > SYSTEM SETUP > SKYVIEW NETWORK SETUP > CONFIGURE > (right click) > DETECT (button).
- The SV-KNOB-PANEL(s) will be listed.
- FINISH (button) > EXIT (button).

7.3 Post Installation Checks

- Verify the knobs work as expected.
- Verify dim commands from SkyView display dim the backlighting of the SV-KNOB-PANEL.

8 SV-BAT-320 Backup Battery



Figure 37: SV-BAT-320 Backup Battery

This section contains information that specifically applies to the installation of the SV-BAT-320 Backup Battery. After reading this section, you should be able to determine how to prepare the installation location, mount the module, connect it to a display, monitor its voltage, and ensure it is charged.



SkyView displays are designed to work only with the SV-BAT-320 as a backup battery in case of loss of aircraft power. Connecting any device other than the SV-BAT-320 to SkyView display Pin 2(+) and Pin 23 (-) will void any warranties and is a significant safety hazard.

Do not extend the SV-HARNESS-D37's cable that connects to the SV-BAT-320.



An SV-BAT-320 can only power one (1) SkyView display. *Do not modify the cable to the SV-BAT-320 to attempt to power more than one (1) SkyView display from one (1) SV-BAT-320.*

A SkyView display can only be powered by, and charge, one (1) SV-BAT-320. *Do not modify the cable to the SV-BAT-320 to attempt to connect more than one (1) SV-BAT-320 to a SkyView display.*

The SV-BAT-320 is a Lithium-Ion (Li-Ion) battery such as is used in mobile phones, laptops, and tablet computers. It is designed to power a SkyView display, and devices powered by the SkyView display for at least 60 minutes if aircraft power is lost.

8.1 Mechanical Installation

The following diagram shows the mounting dimensions of the SV-BAT-320.

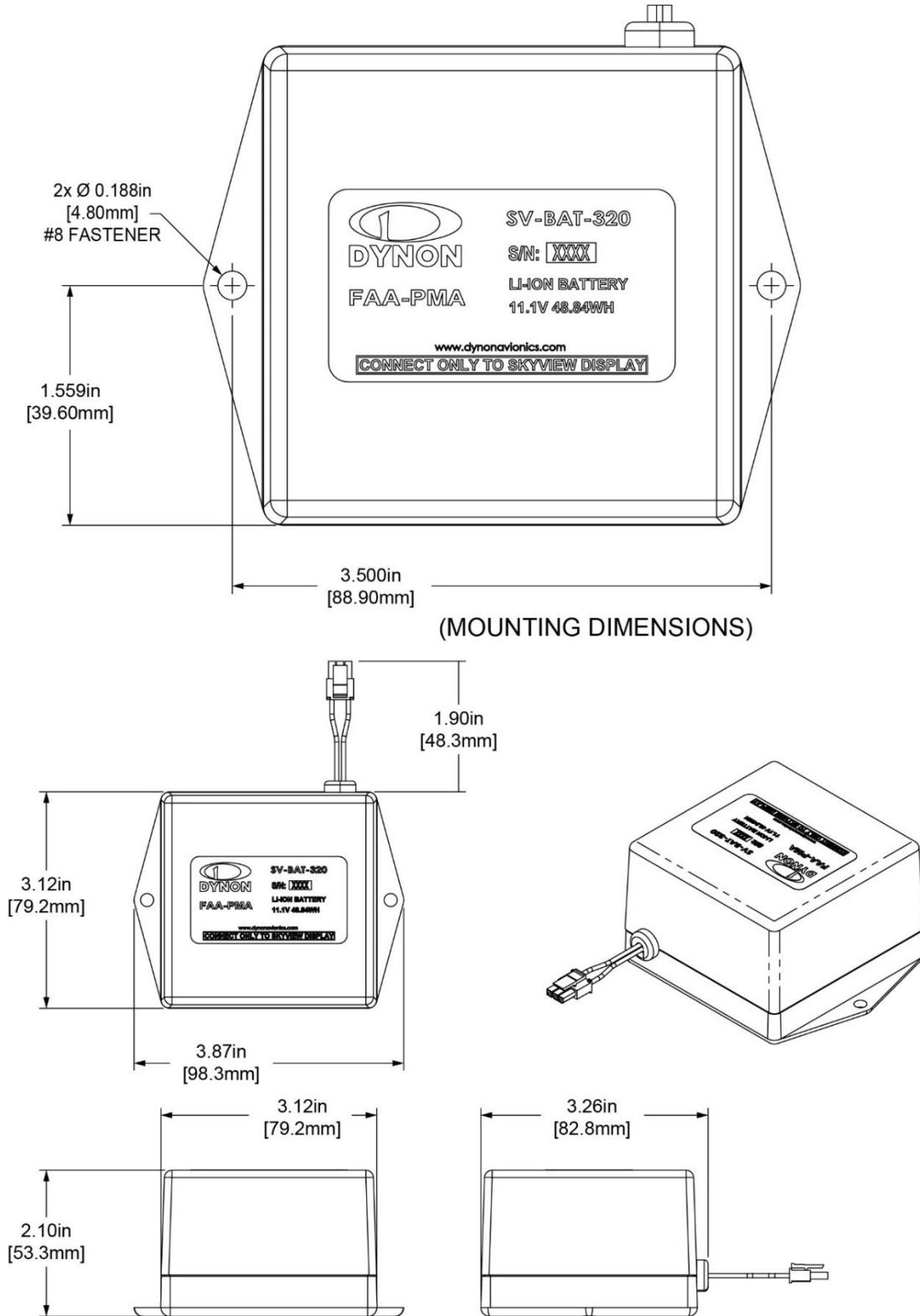

Figure 38: SV-BAT-320 Mounting Dimensions

8.1.1 SV-BAT-320 Location

The normal location is on the avionics tray behind the display. If the battery cannot be mounted there, observe the following guidelines when choosing a location for an SV-BAT-320:

- Location should be near the rear of the SkyView display. A 24" cable is included on the SV-HARNESS-D37 for connecting the SV-BAT-320. *This cable should not be extended.*
- Avoid locations that are subject to severe vibration.
- Avoid locations that are subject to extended temperature ranges. *The SV-BAT-320 has a narrower operating temperature range than other SkyView modules.*
- Avoid locations that are subject to extreme humidity.
- Leave room for electrical connections.

Mounting hardware is not included with the SV-BAT-320. The mounting tabs on each side of the module have holes sized for #8 fasteners. Button head style AN hardware is recommended as spacing between the holes in the tabs and the body of the enclosure limits what style tool can be used to tighten certain fasteners. Follow recommended torque practices when tightening the mounting hardware (see Caution below).



The SV-BAT-320 enclosure is made of plastic that may crack if too much torque is applied to the fasteners and the mounting tabs of the SV-BAT-320. The appropriate amount of torque that should be applied is a combination of the mounting base material, its thickness, the fastener, the presence or absence of thread lock compound on the fastener, and the tolerance stack up of the diameters of the mounting hole and the fastener. Apply sufficient torque that the fasteners will not self-release, but not so much that the mounting tabs will eventually break from too much stress.

Use of ferrous fasteners in this location is acceptable. *Do not rivet the SV-BAT-320 to the aircraft as this will hinder future removal if necessary.*

8.2 Electrical Installation



For warranty replacement, an SV-BAT-320 that is received at Dynon Avionics with a different connector than the factory-installed connector is not eligible for warranty replacement.

Connect the SV-BAT-320 module's connector to the mating connector on the SV-HARNESS-D37.

If you are constructing your own SkyView display harness (equivalent to the Dynon Avionics SV-HARNESS-D37), do not cut off the connector on the SV-BAT-320 to install a different connector. See Section 31 *Appendix C: Wiring and Electrical Connections*, Non-Dynon Avionics Wire Harness Considerations for details on the mating connector for the SV-BAT-320.

8.3 Charging the SV-BAT-320



Do not attempt to charge the SV-BAT-320 using any other charging unit. Doing so may risk damaging the SV-BAT-320. The only safe method of charging an SV-BAT-320 is to connect it to a SkyView HDX display.

8.3.1 SV-BAT-320 is Automatically Charged in Flight

An SV-BAT-320 connected to a SkyView display is automatically charged by the SkyView display when there is adequate power applied to the SkyView display. If the SV-BAT-320 becomes discharged, on the next flight the SkyView display will automatically charge the SV-BAT-320. Charging, when necessary, required a minimum input voltage of 12.25 Volts supplied to the SkyView display. To prevent discharging the aircraft battery excessively (when not in flight), the SkyView display will not attempt to charge the SV-BAT-320 when the input voltage to the SkyView display is lower than 12.25 volts.

8.3.2 Charging the SV-BAT-320 on Ground or During Aircraft Construction



As with all new lithium-ion batteries, the SV-BAT-320 is manufactured, stored in inventory (Dynon Avionics, dealers, and aircraft manufacturers), and shipped in a *partially-charged state*. Occasionally, typically after a year or more with no charging, the SV-BAT-320 may appear to be fully discharged – the SkyView display may not be able to detect that a battery is installed.

To prevent becoming totally discharged, all lithium-ion batteries, including the SV-BAT-320, incorporate internal safety circuitry (protection mode) that will disconnect the load (SkyView display) when the lithium-ion battery's state of charge is very low.

Prior to Software v15.0, SkyView displays could not detect when an SV-BAT-320 was in this state (protection mode due to low state of charge) and thus the SkyView display would not attempt to charge the SV-BAT-320. Software v15.0 and later incorporates an improvement to the charging algorithm; the SkyView display can detect this state and charge an SV-BAT-320 that is in protection mode.

As explained above, to prevent discharging the aircraft battery excessively (when not in flight), the SkyView display will not attempt to charge the SV-BAT-320 when the input voltage is lower than 12.25 volts. During aircraft construction, or if the aircraft will not be flown for an extended period, the SkyView display can charge the SV-BAT-320 if the following conditions are met:

- For each SkyView display that will be charging an SV-BAT-320, the aircraft's battery charger must be able to supply at least 5 amps (5A) (for a 12-volt electrical system; 2.5A for a 24 volt electrical system). If you have two (2) SkyView displays with SV-BAT-320s, and you wish to charge them simultaneously, the battery charger must be capable of supplying 10A.

- Under full load (5A), the aircraft battery charger must be capable of supplying 13 volts (13V) to the SkyView display. Supplying 13V to the aircraft electrical system allows for voltage drops in the electrical system, ensuring that the SkyView display receives at least 12.25V that is required to charge an SV-BAT-320.
- It may take as long as four (4) hours (4H) to fully charge a fully discharged SV-BAT-320.
- To charge an SV-BAT-320, the SkyView display must be powered ON and fully booted up. The SkyView Software monitors the charging process; if the SkyView display is powered off, the SV-BAT-320 will not be charged.

8.4 Battery Status Icon

Battery status icon is individual to each display in a SkyView system. One (1) of two (2) icons, or no icon will be displayed immediately to the left of the clock in the center of the top bar.

8.4.1 No Battery Icon Displayed

- No battery has ever been connected to this display or battery status is normal. If a battery is connected, all the following are true:
 - An Initial SV-BAT-320 Test has been performed.
 - The Annual SV-BAT-320 Test is not yet due.
 - The last three (3) automatic SV-BAT-320 self-checks were normal. SV-BAT-320 self-checks are performed automatically every time master power is removed on the ground (after a flight, for example) while the 30-second "power lost" timer is counting down.

Needs Test Icon:



- SkyView has determined that the SV-BAT-320 should be tested using the manually-actuated SV-BAT-320 Test. This is because:
 - It has been one (1) year since the last battery test. See the Detailed Battery Status Check section below for details about the nature of the anomaly.
 - The 30 second automatic battery self-check that is performed when master power is removed during a normal shutdown did not complete properly at least 3 consecutive times.

Fault/Test Failed Icon:

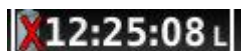

- A fault has been detected because of one (1) of the following conditions:
 - The battery is no longer connected.
 - A battery test has failed. See the following sections for more information.

8.5 Detailed Battery Status Check

Enter the Display Hardware Information Page:

(SETUP MENU > LOCAL DISPLAY SETUP > BATTERY BACKUP (SV-BAT-320) STATUS to check the status of the battery.

- BATTERY CONNECTED (BATTERY DETECTED): YES / NO.
 - SkyView automatically sets this to yes when a battery is installed.
- LAST BATTERY SHUTDOWN:
 - NORMAL.
 - ABNORMAL: The last shutdown of SkyView did not happen normally.
 - WEAK BATTERY: SkyView detected a low battery voltage condition when SkyView was last shut down. The battery may be discharged or may need replacement. SkyView will annunciate a warning if this happens repeatedly.
- DATE OF LAST TEST: UNTESTED / MM-DD-YYYY.
 - If this date is over a year ago, SkyView will annunciate BATTERY TEST NEEDED upon startup. Follow the steps in Initial SV-BAT-320 Test below.
- TEST RESULT:
 - FAIL: VOLTAGE DROP TOO HIGH: Battery likely needs to be replaced. Contact Dynon Avionics Technical Support (contact information at the beginning of this manual).
 - FAIL: LASTED xx MINS: Battery likely needs to be replaced. Contact Dynon Avionics Technical Support (contact information at the beginning of this manual).
 - PASS BATT LIFE > 45 MIN: The last full test of battery passed.
- BATTERY STATUS: (voltage).
- CHARGE STATUS: CHARGING/DISCHARGED/CHARGED/STANDBY/NO BATTERY.



An SV-BAT-320 is fully charged when it reaches 12.25 volts. Charging a completely discharged battery may take up to 4 hours. To conserve your aircraft battery, the SV-BAT-320 only charges when SkyView detects that your alternator or generator is running (whenever your engine is running), which is when SkyView's input voltage is above 12.25V. Alternatively, connecting a battery charger to your aircraft battery will also raise the input voltage to a level that will allow SkyView's SV-BAT-320 to charge.



The SV-BAT-320 must only be charged by SkyView. External charging of the battery is not supported. External charging of the battery can damage it or cause it to explode.

8.6 Initial SV-BAT-320 Test

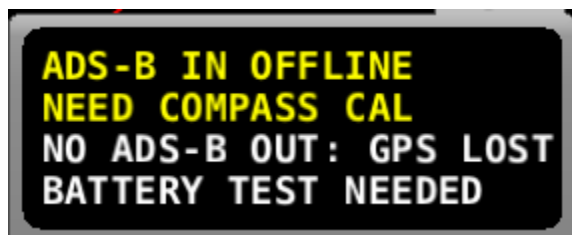

Figure 39: BATTERY TEST NEEDED Message

The Initial SV-BAT-320 Test is performed to ensure that an SV-BAT-320 is fully functional after installation is complete. SkyView records the date of the last battery test (if any) and will annunciate, via a message and an icon in the top bar, when an initial, or annual battery test is required. For instructions on performing the *annual* SV-BAT-320 test, see Section the *SkyView HDX General Maintenance Manual* document.

An SV-BAT-320 is designed to (when fully charged) power a SkyView display and devices powered by a SkyView display, for at least 60 minutes if aircraft power is lost. The Initial SV-BAT-320 Test ensures that an SV-BAT-320 has adequate capacity by discharging it while recording the time elapsed.

If your SkyView system has more than one (1) SkyView display with an SV-BAT-320 installed, perform the following test individually on each SkyView display.

Test Procedure

1. The SV-BAT-320 must be fully charged prior to commencing this test. Reference the section Charging the SV-BAT-320 above for information on charging the SV-BAT-320.
2. Apply power to the SkyView display you will be testing. If all your SkyView displays power up from a single switch or circuit breaker, power down any display other than the unit on which you will perform the SV-BAT-320 test – push and hold Button 1 (HOLD TO POWER DOWN).
3. Remove power to the SkyView display you will be testing. If all your SkyView displays power up (and power down) from a single switch or circuit breaker, push the POWER OFF button on the SkyView display(s) that are not being tested. That SkyView display will be powered off.
4. On the SkyView display that is being tested, during the 30 second power off countdown, press the TEST BAT button above button 8 (far right button) – see Figure 40 below.



Figure 40: TEST BAT Button Appears After Removing Power to SkyView Display

5. The BATTERY TEST screen will appear displaying the status of the test. If the SV-BAT-320 can power the system for at least 45 minutes, the SV-BAT-320 passes this test.

6. After the test completes (successfully, or unsuccessfully), the SkyView display will automatically power off.
7. To see the results of the test, enter the SETUP MENU > LOCAL DISPLAY SETUP > BATTERY BACKUP (SV-BAT-320) STATUS>TEST RESULTS. Make sure the TEST RESULT says PASS.
8. The BATTERY TEST can be aborted by pressing the PWR OFF button.

Repeat the test procedure for each SkyView display that has an SV-BAT-320 installed.



This test discharges the SV-BAT-320. Recharging the SV-BAT-320 after the test is recommended, either by flying for approximately four (4) hours or using the procedure above to charge the SV-BAT-320 on the ground.

8.6.1 In the Event of Initial SV-BAT-320 Test Failure



See dynon.com/warranty for the most current information on Dynon Avionics warranty terms and conditions.

Note that if an SV-BAT-320 is replaced under warranty, the defective SV-BAT-320 must be returned (at customer's expense) to Dynon Avionics to avoid being charged full purchase price of a new SV-BAT-320.

If a new SV-BAT-320 does not pass the Initial SV-BAT-320 Test, contact Dynon Avionics Technical Support (contact information at the beginning of this manual) for further assistance. Please have the S/N of the SV-BAT-320 (printed on the SV-BAT-320 product label) available when you call. Note that warranty terms and conditions apply to a new SV-BAT-320.

8.7 SV-BAT-320 Specifications

Specifications for the SV-BAT-320 can be found in Appendix B: Specifications.

8.8 Returning an SV-BAT-320 to Dynon Avionics for Exchange (Warranty Replacement)

If it is necessary to return an SV-BAT-320 to Dynon Avionics for warranty replacement, consult with your shipping company, in your country, *in advance of shipment* regarding the regulations to ship a Lithium-Ion battery such as the SV-BAT-320. Regulations to ship a Lithium-Ion battery *vary widely, depending on the shipping company, country, type of shipping (air, ship, ground, etc.)*, thus Dynon Avionics cannot offer definitive advice on shipping an SV-BAT-320, only this general guidance:

All packages containing lithium batteries are classified as Class 9 — Miscellaneous Dangerous Goods. However, packages containing small amounts of lithium may be exempted from most of the IATA and ICAO requirements if they comply with the requirements in Section II IATA (which matches Section II ICAO) Packing Instructions (PI) 965, 966, and 967 for lithium-ion batteries and 968, 969 and 970 for lithium metal batteries as appropriate.

For purposes of shipping, Lithium-Ion batteries manufactured for Dynon Avionics are deemed to contain minimal lithium, below thresholds that require special arrangements.

To support returning an SV-BAT-320 to Dynon Avionics for warranty replacement, a Material Safety Data Sheet (MSDS) for the SV-BAT-320 is available upon request – contact Dynon Avionics Technical Support (contact information at the beginning of this manual). Packages containing a lithium-ion battery require an associated warning labeled.

9 SV-ADAHRS-200 ADAHRS

The SkyView SV-ADAHRS-200 ADAHRS module uses solid state sensors to accurately measure inertia, accelerations, magnetic fields, and air pressure. To ensure accuracy in its readings, it is very important that you install the module correctly and perform the specified calibration steps. This section guides you through that process.



Figure 41: ADAHRS 200



Proper installation of the SV-ADAHRS-200 module(s) is critical. Correct PFD performance is significantly linked to a proper ADAHRS installation. The installation location must meet all of the mechanical, magnetic, orientation, placement, and environmental requirements detailed below.

9.1 Mechanical Installation

The SV-ADAHRS-200 should be located on a rigid surface within 12 feet (3.66 meters) longitudinally and 6 feet (1.83 meters) laterally of the aircraft's center-of-gravity. Figure 42: SV-ADAHRS-200 with Respect to Center-of-Gravity illustrates this criterion.

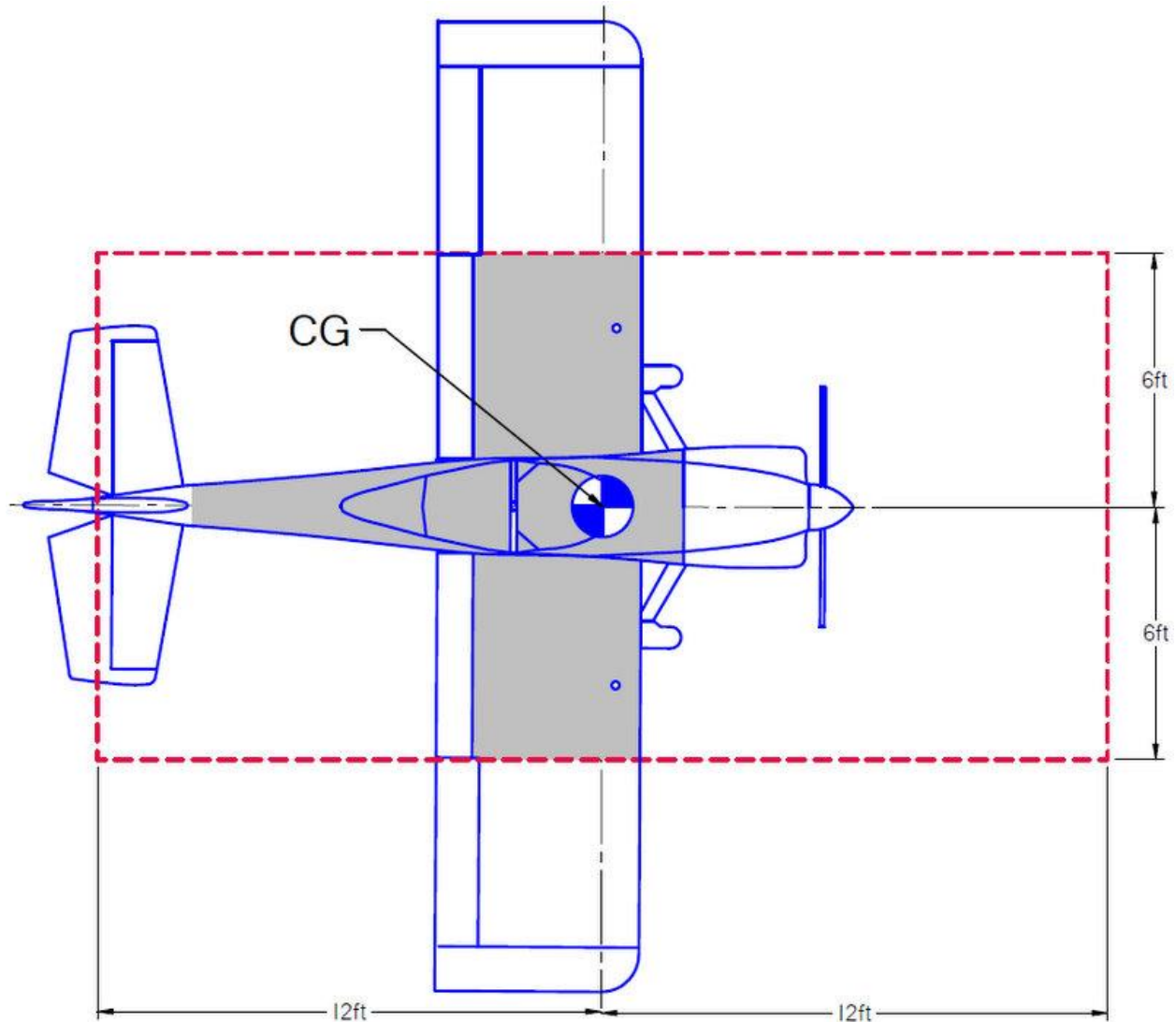

Figure 42: SV-ADAHRS-200 with Respect to Center-of-Gravity

Mounting requirements for the SV-ADAHRS-200:

- Must be mounted within one (1) degree of parallel to all three (3) aircraft axes,
- The pneumatic fittings must face toward the front of the aircraft,
- The mounting tabs must be towards the bottom of the aircraft, with the label towards the top of the aircraft.

Figure 43 shows the correct orientation of the ADAHRS as it would appear if you were above the aircraft, looking down at it. The module will not operate properly if it is rotated, or inverted, or in any other orientation.

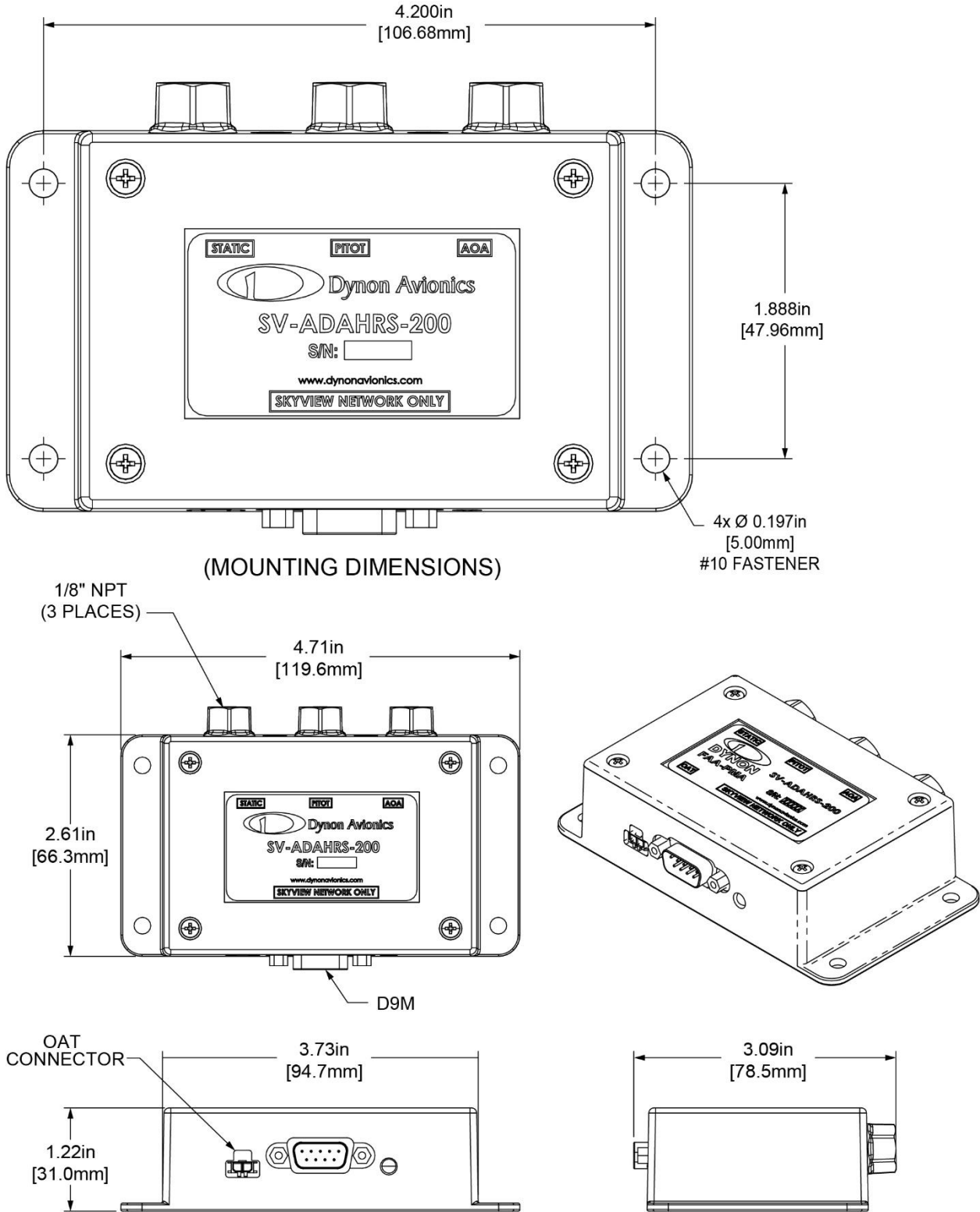

Figure 43: SV-ADAHRS-200 Mounting Dimensions and Orientation

The ADAHRS installation location should also adhere to the following requirements:

- Avoid locations that are lower than the lowest point in the AOA/Pitot/Static system to reduce the chance of allowing moisture to enter the module.
- Avoid locations that are subject to severe vibration.
- Avoid locations that are subject to rapid changes in temperature.
- Avoid locations that are subject to extreme humidity.
- Leave ample working room for electrical and pneumatic connections.

Table 16: SV-ADAHRS-200 Inputs and Sensors describes which sensors and inputs are used to generate displayed instruments.

Table 16: SV-ADAHRS-200 Inputs and Sensors

Displayed Instrument	GPS	Pitot	Static	AOA	Internal Magnetometer	Remote Magnetometer	Rate Sensors	Accelerometer	OAT
Airspeed		✓	✓						
Altitude			✓						
Angle of Attack (AOA)		✓		✓					
Attitude *GPS used only during Pitot failure	✓*	✓	✓				✓	✓	
Ball								✓	
Density Altitude (DA)									✓
Flight Path Marker (Internal Magnetometer)	✓		✓	✓	✓		✓	✓	
Flight Path Marker (External Magnetometer)	✓		✓	✓		✓	✓	✓	
Ground Speed (GND)	✓								
Heading (HDG) (Internal Magnetometer)		✓	✓		✓		✓	✓	
Heading (HDG) (External Magnetometer)		✓	✓			✓	✓	✓	
Heading (HDG) (Magnetometer Fail)	✓	✓	✓				✓	✓	
Synthetic Vision (Internal Magnetometer)	✓	✓	✓		✓		✓	✓	

Displayed Instrument	GPS	Pitot	Static	AOA	Internal Magnetometer	Remote Magnetometer	Rate Sensors	Accelerometer	OAT
Synthetic Vision (External Magnetometer)	✓	✓	✓			✓	✓	✓	
True Airspeed (TAS)		✓	✓						✓
Turn Rate		✓	✓				✓	✓	
Winds (Internal Magnetometer)	✓	✓	✓		✓				✓
Winds (External Magnetometer)	✓	✓	✓			✓			✓



To ensure that the Slip/Skid Ball will be displayed as centered during flight, the SV-ADAHRS-200 must be installed to 0° (absolute level). There is no adjustment in SkyView to electronically level the SV-ADAHRS-200. If, after installation, the Slip/Skid Ball is not centered, you will need to shim the SV-ADAHRS-200 to be 0° (absolute level). During installation, it may be necessary to use an electronic level as a "spirit" or "bubble" level may not be able to display an accurate enough degree of level.

9.2 Electrical Installation

Connect the SV-ADAHRS-200 to the SkyView network using the cabling mentioned in Section 3.4: Wire Harnesses & Network Cables or using equivalent.

If you have to install a connector on the end of a network cable, insert all pins into the D9 connector. Refer to Section 31 *Appendix C: Wiring and Electrical Connections* for details on connector pinouts and wire colors.

9.3 Compass Calibration



Dynon Avionics calibrates every SV-ADAHRS-200 during manufacture. After the aircraft build is complete, an in-aircraft compass calibration must be performed. Until the on-ground or the in-flight compass calibration is performed, SkyView will display a Caution message: NEED COMPASS CAL.

Performing an In-flight Compass Calibration after the On-ground Compass Calibration can increase the accuracy of the compass' magnetic heading. The best compass performance will be achieved by perform the on-ground compass calibration, then performing the in-flight compass calibration. It is not required that the in-flight compass calibration be performed immediately after the on-ground compass calibration.

The on-ground compass calibration requires pointing the aircraft in four (4) directions and acquiring data at each direction. An accurate method of aligning the aircraft with magnetic North, East, South, and West, such as an airport's compass rose, is required. *During the*

compass calibration, the aircraft's configuration and major systems should be in a state that resembles flight conditions (i.e., the canopy should be closed, the aircraft's pitch attitude matches SkyView's attitude depiction, the engine should be running, and all electronic devices used in flight should be on).



Tail wheel equipped aircraft can be calibrated in their normal nose up ground attitude if the SkyView attitude display shows the correct corresponding nose up attitude.



A working GPS receiver with a view of the sky to acquire GPS data must be connected to the SkyView system to perform a compass calibration. SkyView uses GPS-derived position information to calculate magnetic intensity, declination, and variation.



During the on-ground compass calibration it is important to perform the compass calibration in an area that has been verified to be magnetically neutral. The presence of steel reinforcement (rebar), electrical power lines under the tarmac, or other natural deposits of ferrous metals can result in an inaccurate compass calibration. Airport compass roses are usually verified to be magnetically neutral and thus are often a good location for performing a compass calibration.

For more information on this issue see FAA Notice Number: NOTC4031:
https://www.faa.gov/files/notices/2012/Aug/CAUTION_TLP_031612_Rev10.pdf

9.3.1 On-ground Compass Calibration Procedure:

1. Turn on the SkyView system and allow it to warm up for a minimum of 5 minutes.
2. Move the aircraft into position so that it is convenient to orient it in the four (4) cardinal directions.
3. Enter the Setup Menu on the SkyView display and go to the Compass Calibration Wizard (SETUP MENU > HARDWARE CALIBRATION > ADAHRS CALIBRATION > COMPASS CALIBRATION). Note - GPS data on the Compass Calibration Page must be green. If it is red, GPS data is not valid.
4. Orient the aircraft to North, South, East, or West.
5. When the aircraft is stable at the chosen orientation, push the button indicating the direction the aircraft is oriented in. Example – when the aircraft is pointed North, push the NORTH button.
6. Wait for data collection to reach 100%.
7. Rotate to the next cardinal direction and repeat steps 4, 5, and 6 for any remaining headings.
8. If there is an SV-ADAHRS-200 installed, the Compass Calibration is performed simultaneously. If the Compass Calibration fails on only one (1) of the units, a message will appear: CALIBRATION FAILED – S/N xxxx

9. CALIBRATION COMPLETE appears when calibration is complete. Press FINISH to return to menu navigation mode.

9.3.2 In-flight Compass Calibration Procedure:



The in-flight compass calibration should be conducted on a clear, VFR day. Before commencing the compass calibration, ensure that you have adequate altitude, clear weather, no traffic, no obstructions in the flight path, great visibility, no airspace conflicts, etc. It is recommended that clearing turns be performed before executing each procedure.

It is recommended that you bring someone along for the in-flight compass calibration procedure. At times, the pilot's attention will be divided between documentation, configuring SkyView, and maintaining situational awareness.

Confine the flying for the in-flight compass calibration to a specific area to minimize variations in the earth's magnetic field during the calibration process (IE, do not combine the in-flight compass calibration with a cross-country flight).

While the in-flight compass calibration is optional, it will likely improve the dynamic performance of the heading indications in many aircraft. It is especially recommended in aircraft where the SV-ADAHRS-200 was, by necessity, installed in an area of the plane that was not entirely clear of magnetic interference. This is particularly true in steel framed aircraft.



The best compass performance will be achieved by performing the in-flight compass calibration *after the on-ground compass calibration has been performed.*

1. If you have two (2) SkyView displays, the in-flight compass calibration can be performed from either display.
2. After observing the cautions above, push buttons 7+8 to enter the IN FLIGHT SETUP MENU. Note – this menu is not accessible while on the ground.
3. Select COMPASS CALIBRATION.
4. Right-click the knob to enter the in-flight COMPASS CALIBRATION menu. You will see a screen like this:

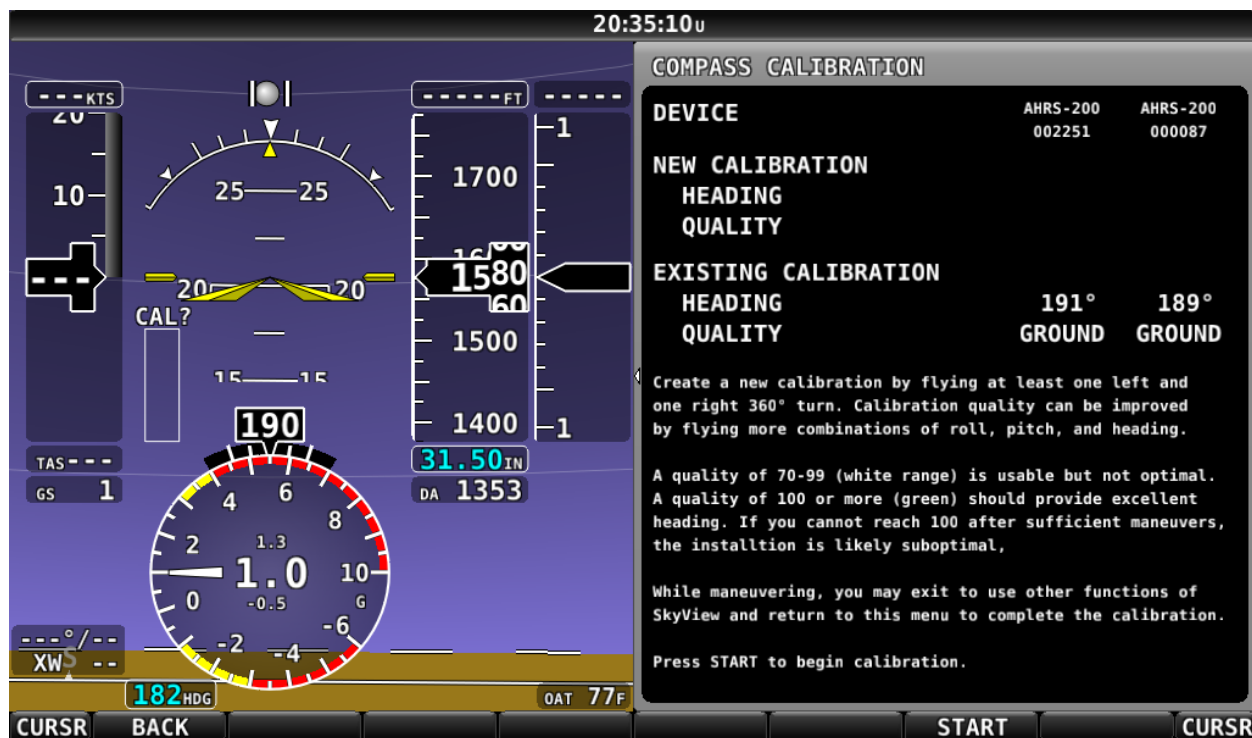

Figure 44: In-flight Compass Calibration Menu

5. Push the START button to begin the calibration.
6. Observe the NEW CALIBRATION section of the menu. The goal of the in-flight compass calibration is to achieve a compass calibration "quality" of at least 100.
7. The minimum amount of maneuvers for in-flight compass calibration is one (1) 360° turn clockwise, and one (1) 360° turn counterclockwise. Flying additional maneuvers incorporating pitch and roll changes will likely improve the in-flight compass calibration.
8. When the quality is as high as you can obtain (above 70, the minimum), push the FINISH button to complete the in-flight compass calibration. Flying additional maneuvers beyond the minimum may improve the in-flight compass calibration but will not make it worse.

QUALITY of 70-99 is acceptable, but not optimum; the accuracy of your magnetic heading may not be acceptable. Additionally, a sub-optimal QUALITY may have the following effects:

- Degraded performance of the SkyView Autopilot (AP) in HDG and NAV modes.
- Degraded accuracy of wind direction and velocity.

If, after multiple attempts at in-flight compass calibration, you cannot achieve QUALITY of at least 70, the compass sensor in the SV-ADAHRS-200 cannot sense the earth's magnetic field with enough precision (excessive magnetic interference). It should be considered to change the location of the SV-ADAHRS-200.

9.4 PFD-Related Settings

Once the physical ADAHRS installation is complete, it may be necessary to configure PFD-related ADAHRS settings for the SkyView system. *All ADAHRS settings are automatically shared between displays in multi-display systems.*

9.4.1 Aircraft Icon

The airplane symbol at the center of the compass rose on the PFD Page, and the center of MAP Page can be changed. There are a variety of airplane types available, including "Fighter", "Jumbo", and "Twin", and more. The symbol can be set in SYSTEM SETUP > AIRCRAFT INFORMATION > AIRCRAFT ICON. There is no "preview" of the symbol – change it and see how you like it in the PFD and the MAP.

9.4.2 Measurement Units

Set altitude, distance and speed, temperature, barometer, and pressure measurement units as detailed in Section 27.3.8: *How to Configure Units of Measure.*

9.4.3 Airspeed Limitations

Use the values on this page to set IAS tape colors. Set V-speed (e.g., stall speed in landing configuration) thresholds on the Airspeed Limitations Page (SETUP MENU > PFD SETUP > AIRSPEED LIMITATIONS). If your aircraft limitations are expressed in TAS rather than IAS, set Vne EXPRESSED AS: TAS.

If you do set Vne EXPRESSED AS: TAS, this will affect the Autopilot Pitch Axis MAXIMUM AIRSPEED.

The values on this page are default values that act as placeholders. You must adjust these values to work with your aircraft for any colors to show up on the IAS tape and also to be able to calibrate the autopilot servos.

9.4.4 Vertical Speed Scale

Set the vertical speed scale on the Vertical Speed Scale Page (SETUP MENU > PFD SETUP > VERTICAL SPEED SCALE).

9.4.5 G Meter

Go to this page (SETUP MENU > PFD SETUP > G METER) to configure the G meter.

The pop-up thresholds are G values that, when exceeded, will cause the G meter to display automatically. The G meter replaces the HSI when it is displayed. In addition to popping up automatically, the G meter can be manually toggled on and off using the PFD > G METER button. If you do not want the G meter to ever be displayed automatically, set the positive pop-up threshold value very high and the negative pop-up threshold value very low.

You can also set yellow and red cautionary ranges of the G meter here, and whether or not the max/min recorded Gs are reset at each SkyView boot-up.

9.5 Other ADAHRS Calibrations

9.5.1 Altitude Offset

There is a single point altitude adjustment, located in SETUP MENU > HARDWARE CALIBRATION > ADAHRS CALIBRATION > ALTITUDE OFFSET that adjusts SkyView's barometric altimeter. This adjustment affects both the displayed altitude and the encoded altitude that is sent to other devices. It should only be adjusted if altitude is found to be incorrect (by comparing it against a known source or field elevation, *after* the BARO setting has been set to correctly to known atmospheric conditions) after SkyView has fully warmed up.

9.5.2 Zero Pressure IAS / AoA Calibration

NOTE: Perform this calibration even if airplane is not equipped with an AoA Probe to properly set zero IAS.

This calibration routine samples Pitot, Static, and AOA pressures in a windless environment to allow SkyView to provide the best possible Indicated Airspeed (IAS) readings at very low airspeeds, and the best possible Angle of Attack (AOA). Ideally, perform this calibration before performing an (in-air) AOA calibration. After performing these two (2) steps, in the future, performing a ZERO PRESSURE IAS/AOA CALIBRATION should restore both airspeed and AOA performance without requiring a full AOA calibration.

It is important that this calibration is done in a windless environment, such as a closed hangar. Additionally, before performing this calibration, cover the Pitot, Static, and AOA ports with a sock or cloth to minimize airflow WITHOUT putting any air pressure on the Pitot, Static, or AOA ports.

To perform the calibration, navigate to SETUP MENU > HARDWARE CALIBRATION > ADAHRS CALIBRATION > ZERO PRESSURE / AOA CALIBRATION and follow the on-screen instructions.

9.5.3 AoA In-Flight Calibration

This calibration should be performed after the Zero Pressure IAS / AoA calibration. It calibrates the AoA system with SkyView HDX.

To perform the calibration, navigate to in SETUP MENU > HARDWARE CALIBRATION > ADAHRS CALIBRATION > AOA CALIBRATION and follow the on-screen instructions.

9.6 Pitot / Static Checks

Dynon Avionics SV-ADAHRS-200 use airspeed in the calculation of attitude (or GPS ground speed when airspeed is unavailable). The internal rate sensors are monitored and calibrated in flight using feedback from the accelerometers and from airspeed to achieve a highly accurate attitude solution.

When a pitot or static test is performed the sensors in the SV-ADAHRS-200 are being exposed to dynamics that are impossible to achieve in a real aircraft flight environment, namely, large airspeed changes without the accompanying accelerations and rotations. This false condition will cause a well-calibrated unit to incorrectly adjust its calibration.

Furthermore, when a unit is in a test situation a change in applied pitot or static pressure will cause the attitude to pitch up or down. This is expected.

Performing the following pitot and static test procedure to a Dynon Avionics SV-ADAHRS-200 will prevent problems with the unit's performance in flight.

9.6.1.1 Test Instructions

- Ensure SkyView is warmed up during each test reading.
- SkyView should be powered off when changing pressures.
- Keep aircraft still (do not move) when pressure is applied.

Steps:

1. The aircraft itself should be temperature stable. For example, if the aircraft is moved from outside in the sun to a hangar for testing, tests should not be started until the airplane has stabilized at the hangar temperature.
2. Turn SkyView on and let it warm up until the altitude reading is stabilized. This period should be at least 5 minutes but may take longer depending on environmental conditions.
3. Turn SkyView off.
4. While SkyView is off, apply the pressure required by your test to pitot and/or static port via your test equipment.
5. Turn on SkyView (external or internal battery power is acceptable). Keep aircraft still while SkyView is powered on. Do not adjust the pitot or static pressures being applied to the ADAHRS while it is powered on.
6. Verify airspeed and/or altitude reading.
7. Turn SkyView off (using button 1 is a good option for this operation).
8. Repeat steps 4-7 for each required pressure point in the test.

See related procedure:

SV-XPNDR-261 Transponder, Performing Transponder Checks.

10 SV-MAG-236 Remote Magnetometer

The SV-MAG-236 provides SkyView with the magnetic heading data. To minimize the possibility of magnetic interference from the connector assembly, the SV-MAG-236 uses an 18-inch integral cable, so that metal connector is removed from the magnetometer sensor.



Figure 45: SV-MAG-236 (Photo)

10.1 Mechanical Installation

The most critical factor in the SV-MAG-236 being able to accurately sense magnetic heading is for it to be installed in an area of the plane that is *magnetically benign*.

Given that it may be difficult or impossible to avoid all sources of magnetic interference, it is possible to characterize and compensate for small, static magnetic fields with calibration. Calibration cannot, however, compensate for *dynamic* magnetic fields (e.g., AC currents, non-constant DC currents, and non-stationary ferrous material such as electric turn coordinators and control surfaces). Thus, you must avoid mounting the module close to sources of *dynamic* magnetic fields, avoid wires that carry large amounts of current, and use non-magnetic fasteners for installation (see caution below). Dynon Avionics' general rule of thumb is that 1 to 2 feet (30.5 cm and 61 cm) between the module and sources of magnetic fields is generally good enough, but 2 (61 cm) or more feet is better.



Stainless steel mounting hardware is not always non-magnetic, and thus *is not recommended*. The best type of mounting hardware (screws, bolts, washers, AND nuts) to install the SV-MAG-236 is brass.



If you use a magnet to test whether possible interfering materials are non-magnetic, do not actually touch the magnet to the material you are testing, as this contact can cause the material you are testing to become magnetized.



Move a handheld compass throughout the space surrounding your intended location to get a rough idea of the suitability of the area. Note that this test should be done with major aircraft systems operating (e.g., strobe lights and radios on) because some systems can cause magnetic interference. If the compass needle deviates significantly from magnetic North or cycles back and forth, the location is not ideal for SV-MAG-236 installation.

The following diagram shows the important mounting dimensions of the SV-MAG-236.

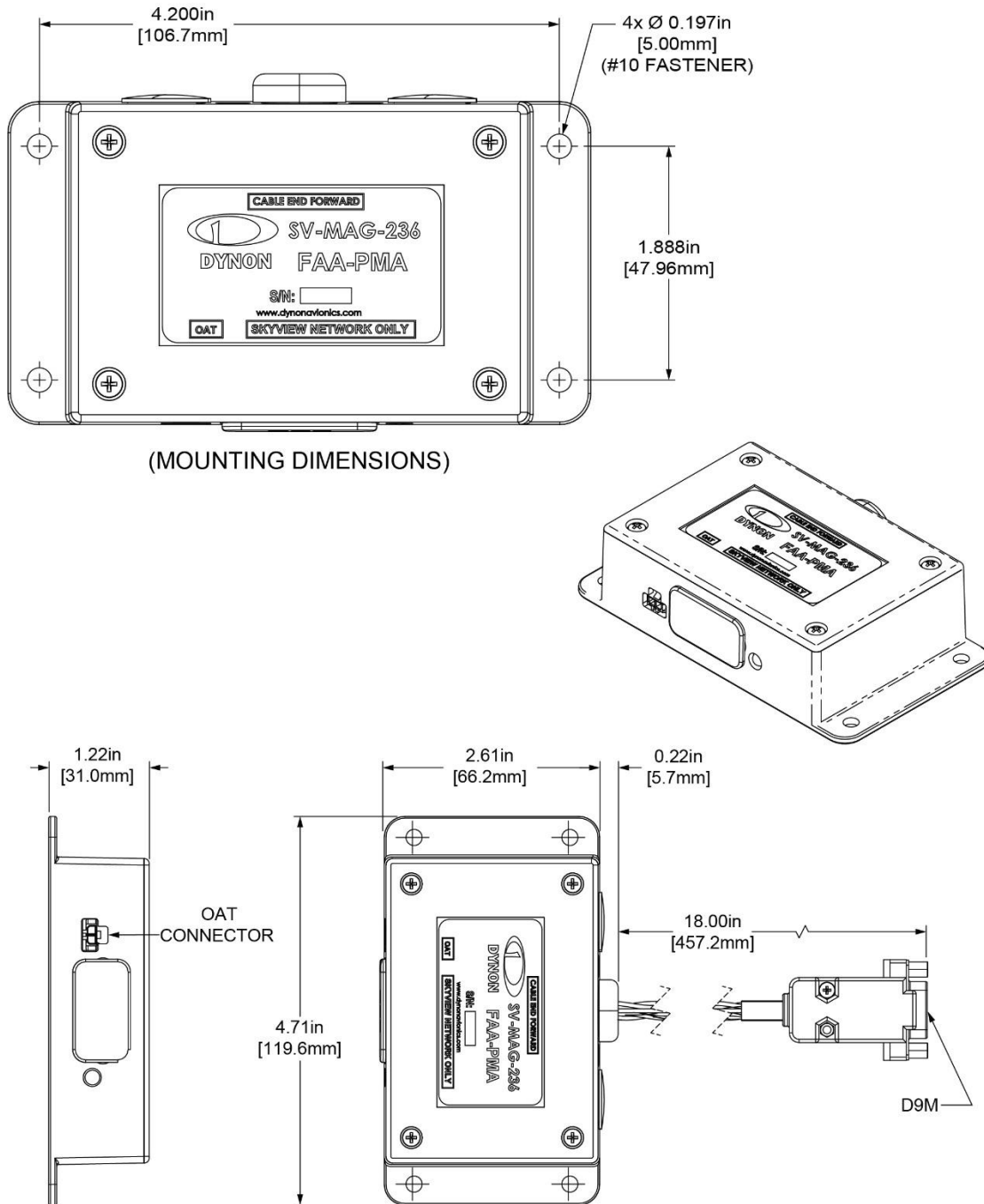

Figure 46: SV-MAG-236 Mounting Dimensions

As with the SV-ADAHRS-200, an SV-MAG-236 should be mounted within one (1) degree of parallel to all three (3) aircraft axes. The SV-MAG-236 should be oriented such that:

- The SV-MAG-236's mounting tabs must be oriented towards the bottom of the aircraft.
- The label on the SV-MAG-236's must be oriented towards the top of the aircraft.
- The side of the SV-MAG-236 where the cable exists must be oriented towards the nose of the aircraft (as noted on the label of the unit – **CABLE END FORWARD**).
- The side of the SV-MAG-236 with the LED indicator must be oriented towards the rear of the aircraft.



The SV-MAG-236 will not be able to indicate correct heading if it is rotated or inverted in any other orientation.



The SV-MAG-236 must be installed in the same orientation as the SV-ADAHRS-200. The SV-ADAHRS-200 is required to be level, and the SV-MAG-236 is also. If the SV-ADAHRS-200 is installed with a pitch other than 0°, the SV-MAG-236 must be installed with the same pitch. As with the SV-ADAHRS-200, it may be necessary to use an *electronic* level as a "spirit" or "bubble" level may not be able to display an accurate enough degree of level.

Dynon Avionics does not provide mounting hardware with SV-MAG-236. The mounting tabs on each side of the module have holes sized for #10 fasteners, but it is up to the installer to decide how the SV-MAG-236 will be secured to the aircraft.

For best performance, it is recommended that button-head style non-ferrous (brass recommended) fasteners be used to install the SV-MAG-236 in this location. Follow recommended torque practices when tightening the mounting hardware. *Do not rivet the SV-MAG-236 to the aircraft as this will hinder future removal if necessary.*



Do not use a magnetic driver when installing the SV-MAG-236. Doing so has the potential to affect the factory magnetic calibration.

10.2 SV-OAT-340 Connected to SV-MAG-236

The SV-ADAHRS-200 includes an SV-OAT-340 and can be used with the SV-MAG-236.

Only one (1) SV-OAT-340 is required in a SkyView system. The SV-OAT-340 can be connected to an SV-ADAHRS-200, or an SV-MAG-236. In a SkyView System which has an SV-ADAHRS-200, and an SV-MAG-236, it is possible to have a total of three (2) SV-OAT-340s, but only one (1) SV-OAT-340 is used by the system at one (1) time. If more than one (1) SV-OAT-340 is installed, the system "chooses" which of the three (2) to use for OAT.

For example, if the SV-ADAHRS-200 is installed in an area of the plane where it is inconvenient to route the SV-OAT-340 wiring, and the SV-MAG-236 is more accessible

to the SV-OAT-340, just connect the SV-OAT-340 to the SV-MAG-236 (instead of to the SV-ADAHRS-200).

Because the SV-OAT-340 is optional for the SV-MAG-236, installation instructions are not included in this section (see Section 11 SV-OAT-340 OAT Sensor).

10.3 Electrical Installation

Connect the SV-MAG-236 to the SkyView network using a SkyView Network Cable. To minimize any potential magnetic interference from the connector, it is recommended to *not* locate the connector near the SV-MAG-236. SkyView Network cables made by Dynon Avionics are available in various lengths, including 6 feet (1.83 m), 10 feet (3.05 m), 15 feet (4.57 m), 20 feet (6.1 m), 25 feet (7.62 m), and 30 feet (9.14 m).

If you must install a connector on the end of a network cable, insert all pins into the D9 connector. Refer to Section 31 *Appendix C: Wiring and Electrical Connections* for details on connector pinouts and wire colors.



Remember to configure the network as described in the

Network Setup and Status section after connecting all modules to a display.

When a NETWORK CONFIGURATION is performed, the internal magnetometer of the SV-ADAHRS-200 is disabled.



When an SV-MAG-236 is installed in a SkyView system, if the SV-MAG-236 fails or is disconnected, GPS Ground Track (GND TRK) is substituted for magnetic heading throughout the system.

10.4 Compass Calibration



Dynon Avionics calibrates every SV-MAG-236 during manufacture. After the aircraft build is complete, an in-aircraft compass calibration must be performed. Until the on-ground or the in-flight compass calibration is performed, SkyView will display a Caution message: NEED COMPASS CAL.

Performing the in-flight compass calibration after the on-ground compass calibration can increase the accuracy of the compass' magnetic heading. The best compass performance will be achieved by performing the on-ground compass calibration, then performing the in-flight compass calibration. It is not required that the in-flight compass calibration be performed immediately after the on-ground compass calibration.

The on-ground compass calibration requires pointing the aircraft in four (4) directions and acquiring data at each direction. An accurate method of aligning the aircraft with magnetic North, East, South, and West, such as an airport's compass rose, is required. *During the compass calibration, the aircraft's configuration and major systems should be in a state that resembles flight conditions (i.e., the canopy should be closed, the aircraft's pitch attitude matches SkyView's attitude depiction, the engine should be running, and all electronic devices used in flight should be on).*



Tail wheel equipped aircraft can be calibrated in their normal nose up ground attitude if the SkyView attitude display shows the correct corresponding nose up attitude.



A working GPS receiver with a view of the sky to acquire GPS data must be connected to the SkyView system to perform a compass calibration. SkyView uses GPS-derived position information to calculate magnetic intensity, declination, and variation.



During the on-ground compass calibration it is important to perform the compass calibration in an area that has been verified to be magnetically neutral. The presence of steel reinforcement (rebar), electrical power lines under the tarmac, or other natural deposits of ferrous metals can result in an inaccurate compass calibration. Airport compass roses are usually verified to be magnetically neutral and thus are often a good location for performing a compass calibration.

For more information on this issue see FAA Notice Number: NOTC4031: https://www.faa.gov/air_traffic/flight_info/aeronav/notices/2012/Aug/CAUTION_TLP_031612_Rev10.pdf

10.4.1 On-ground Compass Calibration Procedure:

1. If you have two (2) SkyView displays, the in-flight compass calibration can be performed from either display.
2. Turn on the SkyView system and allow it to warm up for a minimum of 5 minutes.
3. Move the aircraft into position so that it is convenient to orient it in the four (4) cardinal directions.
4. Enter the Setup Menu on the SkyView display and go to the Compass Calibration Wizard (SETUP MENU > HARDWARE CALIBRATION > ADAHRS CALIBRATION > COMPASS CALIBRATION). Note - GPS data on the Compass Calibration Page must be green. If it is red, GPS data is not valid. You will see a screen similar to this:



Figure 47 – On-ground COMPASS CALIBRATION Menu

5. Orient the aircraft to North, South, East, or West.
6. When the aircraft is stable at the chosen orientation, push the button indicating the direction the aircraft is oriented in. Example – when the aircraft is pointed North, push the NORTH button.
7. Wait for data collection to reach 100%.
8. Rotate to the next cardinal direction and repeat steps 4, 5, and 6 for any remaining headings.
9. If the Compass Calibration fails, a message will appear:
CALIBRATION FAILED – S/N xxxx.
10. CALIBRATION COMPLETE appears when calibration is complete. Press FINISH to return to menu navigation mode.

10.4.2 In-flight Compass Calibration Procedure:



The in-flight compass calibration should be conducted on a clear, VFR day. Before commencing the compass calibration, ensure that you have adequate altitude, clear weather, no traffic, no obstructions in the flight path, great visibility, no airspace conflicts, etc. It is recommended that clearing turns be performed before executing each procedure.

It is recommended that you bring someone along for the in-flight compass calibration procedure. At times, the pilot's attention will be divided between documentation, configuring SkyView, and maintaining situational awareness.

Confine the flying for the in-flight compass calibration to a specific area to minimize variations in the earth's magnetic field during the calibration process (IE, do not combine the in-flight compass calibration with a cross-country flight).

While the in-flight compass calibration is optional, it will likely improve the dynamic performance of the heading indications in many aircraft. It is especially recommended for aircraft with the SV-MAG-236 are installed due to magnetic interference issues when installing the SV-ADAHRS-200. This is particularly true in steel framed aircraft.



The best compass performance will be achieved by performing the in-flight compass calibration *after the on-ground compass calibration has been performed.*

1. If you have two (2) SkyView displays, the in-flight compass calibration can be performed from either display.
2. After observing the cautions above, push buttons 7+8 to enter the IN FLIGHT SETUP MENU. Note – this menu is not accessible while on the ground.
3. Select COMPASS CALIBRATION

Right-click the knob to enter the in-flight COMPASS CALIBRATION menu. You will see a screen similar to this:

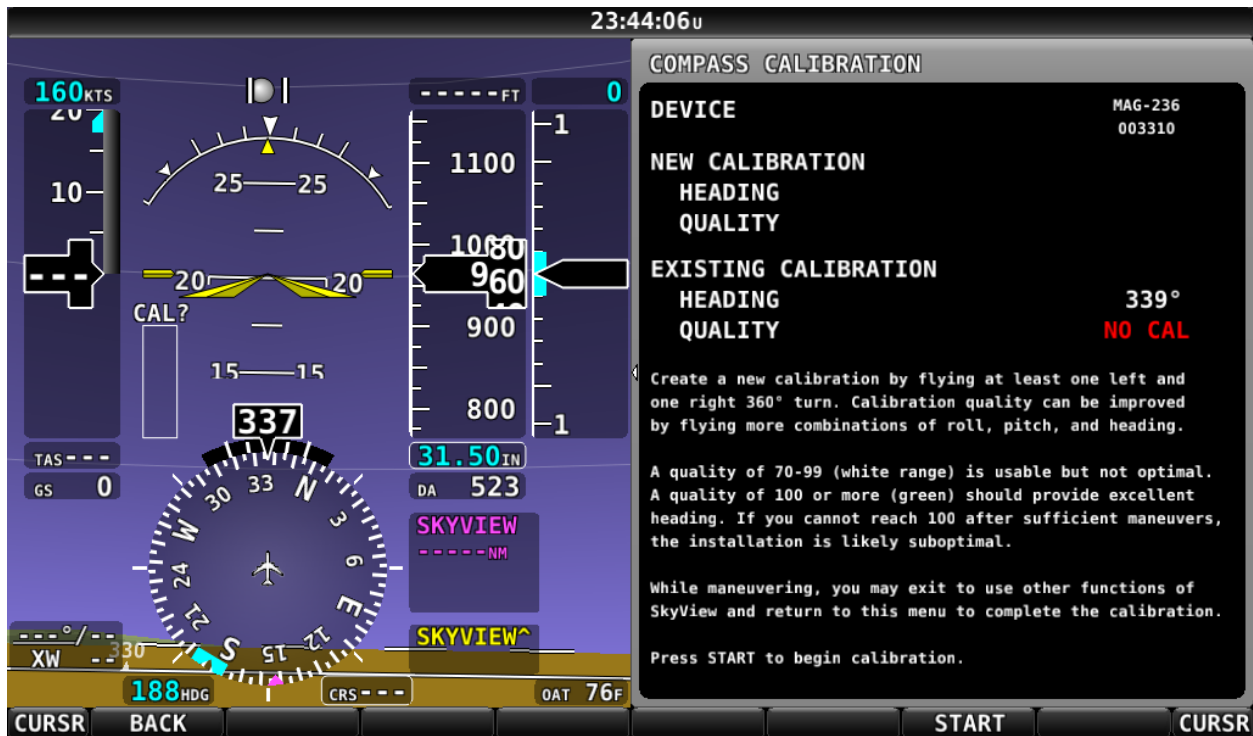

Figure 48: In-flight COMPASS CALIBRATION Menu

1. Push the START button to begin the calibration.
2. Observe the NEW CALIBRATION section of the menu. The goal of the in-flight compass calibration is to achieve a compass calibration "quality" of at least 100.
3. The minimum amount of maneuvers for in-flight compass calibration is one (1) 360° turn clockwise, and one (1) 360° turn counterclockwise. Flying additional maneuvers incorporating pitch and roll changes will likely improve the in-flight compass calibration.
4. When the quality is as high as you can obtain (above 70, the minimum), push the FINISH button to complete the in-flight compass calibration. Flying additional maneuvers beyond the minimum may improve the in-flight compass calibration but will not make it worse.

QUALITY of 70-99 is acceptable, but not optimum; the accuracy of your magnetic heading may not be acceptable. Additionally, a sub-optimal QUALITY may have the following effects:

- Degraded performance of the SkyView Autopilot (AP) in HDG and NAV modes.
- Degraded accuracy of wind direction and velocity.

If, after multiple attempts at in-flight compass calibration, you cannot achieve QUALITY of at least 70, the SV-MAG-236 cannot sense the earth's magnetic field with enough precision (excessive magnetic interference). It should be considered to change the location of the SV-MAG-236.

11 SV-OAT-340 OAT Sensor

The SV-OAT -340 Sensor measures the Outside Air Temperature and provides this data to SkyView by connecting to either the SV-ADAHRS-200 ADAHRS module or the SV-MAG-320 Remote Magnetometer.

11.1 Mechanical Installation

The SV-OAT-340 is an outside air temperature sensor. For it work properly, it must be able to measure air temperature accurately. Avoid exposing the sensor to sources of heat that would interfere with outside air temperature readings such as:

- Direct sunlight.
- Engine heat and exhaust.
- Aircraft interior (back side of sensor).
- Heated air from the cabin exiting from an open window or cabin air exhaust port.

The installation area should have space for a nut and wires on the back side of the sensor. It is acceptable to extend or reduce the wire length if necessary. Reduce the wire length by cutting out the desired length from the middle of the wires and splicing together the remaining ends.

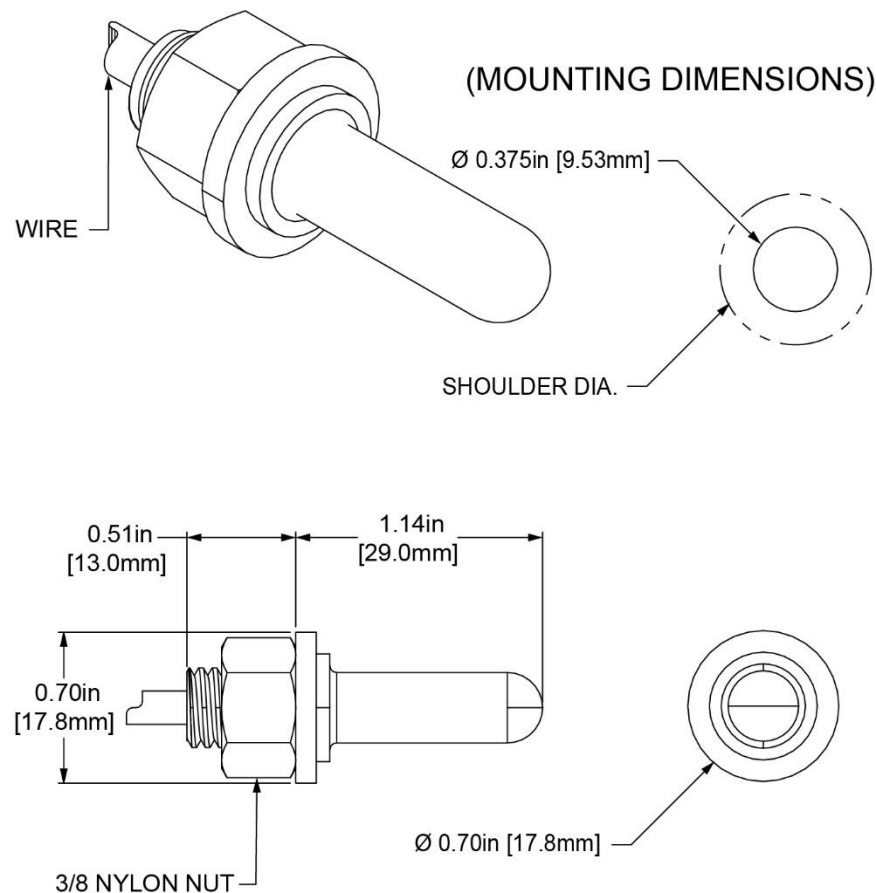

Figure 49: SV-OAT-340 Mounting Dimensions

If there is a backup ADAHRS in the SkyView system, it is acceptable to install a backup OAT sensor a few inches away from the primary sensor. Consider running primary and backup OAT sensor wiring together. Tape sensor wire pairs together to avoid confusion later.



Do not insert the pins on the ends of the OAT sensor wires into the included connector housing until you are done running sensor wiring through the aircraft.

The SV-OAT-340 connector is small and easily lost. One (1) technique to avoid losing this connector is to temporarily tape it to the top of the SV-ADAHRS-200 until it is time to insert the wires into the connector.

On the outside of the fuselage:

1. Drill a 3/8" hole at the installation location.
2. Feed the wires of the sensor through the hole.
3. Feed the body of the sensor through the hole.

On the inside of the fuselage (consider getting assistance for some of the steps below because it may be difficult to be simultaneously on the inside and outside of the fuselage):

1. Feed the nylon washer over the cable.
2. Feed the nylon nut over the cable.
3. Feed the nylon washer over the body of the sensor.
4. Hand-thread the nylon nut onto the threaded body of the sensor. *At this point, the nylon washer should be sandwiched between the nylon nut and the inside of the fuselage.*
5. Carefully tighten the nut using the 9/16" wrench.

11.2 Electrical Installation

Route and secure the sensor wires to the location of the either the SV-ADAHRS-200 ADAHRS module or the SV-MAG-320 Remote Magnetometer. Keep wires away from radios, ignition, and other noisy electronics.

Carefully insert the pins on the wires into the connector housing. Pins are not polarized and lock into place when inserted correctly.

Connect the sensor to the SV-ADAHRS-200 ADAHRS module or the SV-MAG-320 Remote Magnetometer as appropriate.

12 SV-EMS-220 Engine Monitoring System

This section contains information and diagrams that specifically apply to the installation of the SV-EMS-220 Engine Monitoring module and compatible transducers and sensors.



Figure 50: SV-EMS-220

After reading this section, you should be able to determine how to prepare an installation location, how to mount the module and its transducers and sensors, how to make all necessary electrical and transducer and sensor connections, and how to configure the SkyView system for the installation's engine parameter sensing.

SkyView can accept up to two EMS modules connected to the network. Two EMS modules are required for twin-engine airplanes.

12.1 Mechanical Installation

Observe the following guidelines when choosing a location for an SV-EMS-220 Engine Monitor module:

- On single-engine airplanes, the typical location is in the fuselage, behind the firewall, and forward of the instrument panel.
- On twin-engine airplanes, the typical locations are in the engine nacelle and behind the firewall.
- Do not install on the engine side of the firewall.
- Avoid locations that are subject to severe vibration.
- Avoid locations that are subject to extreme humidity.
- Leave ample working room for electrical connections.

The following diagram shows the mounting dimensions of the EMS module with electronic connections.

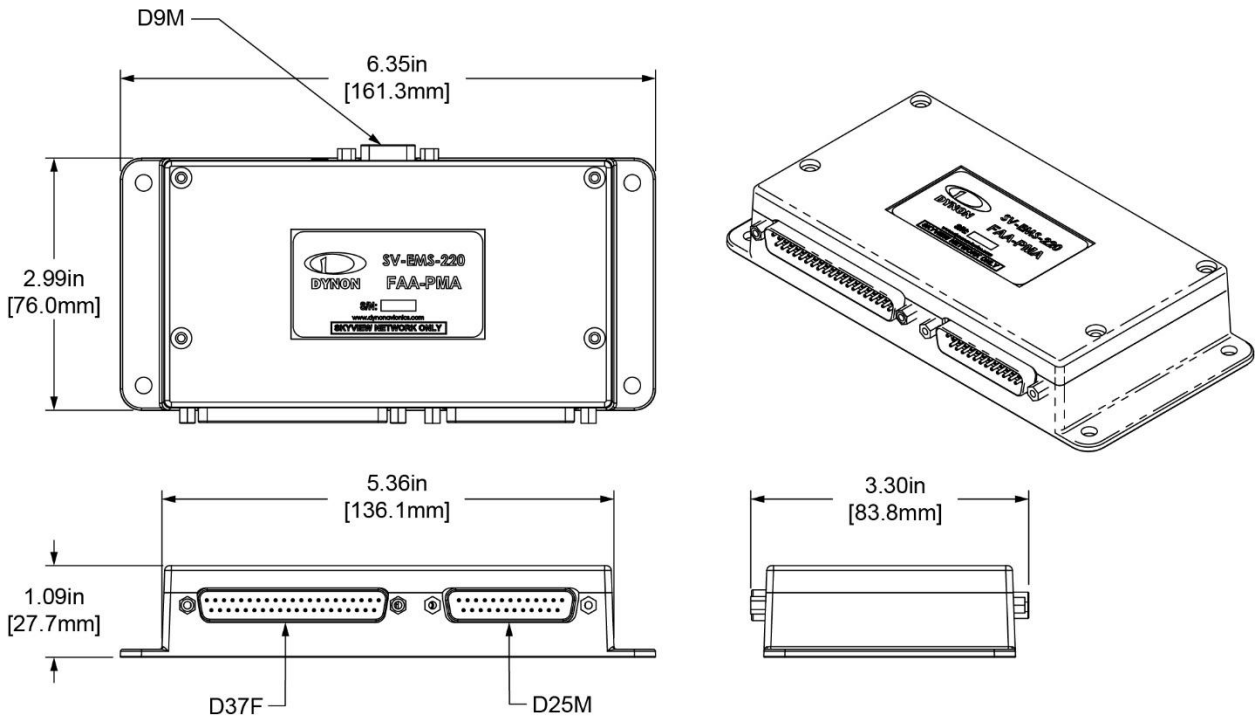
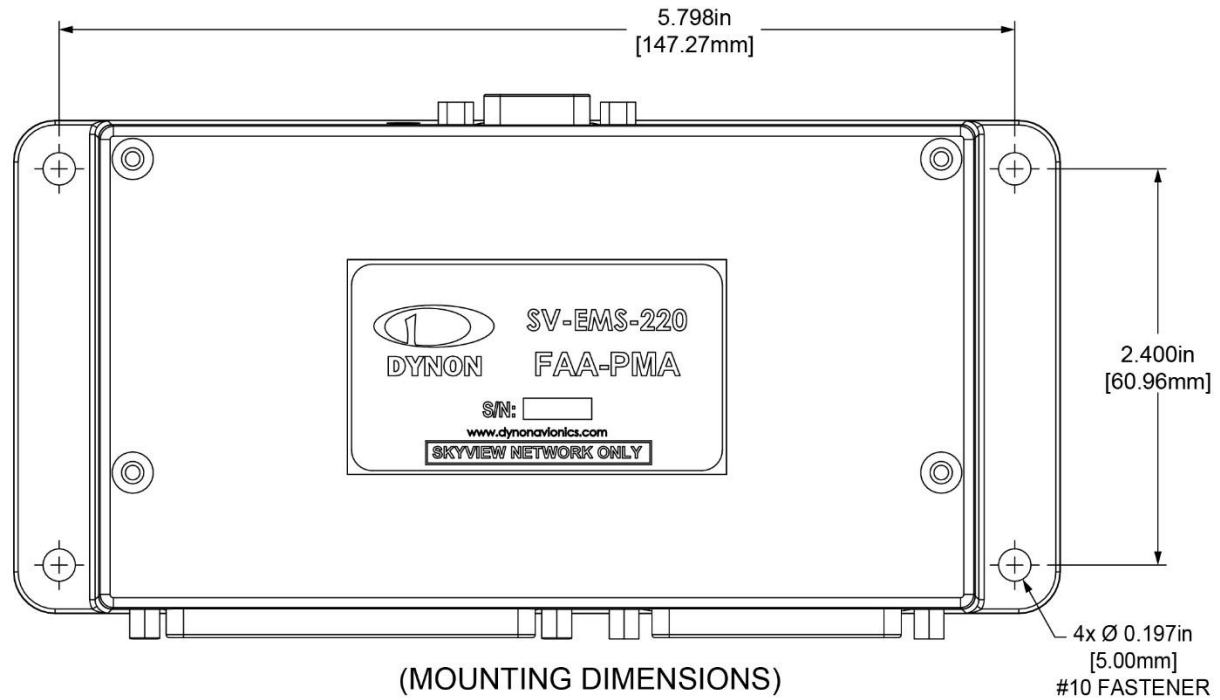

Figure 51: SV-EMS-220 Mounting Dimensions with Electronic Connections

Dynon Avionics does not include mounting hardware for use with the SV-EMS-220. The mounting tabs on each side of the module have holes sized for #10 fasteners, but it is up to the installer to decide how the EMS will be secured to the aircraft. Use of ferrous fasteners in this location is acceptable as the EMS is not adversely affected by small magnetic fields. We recommend button head style AN hardware as spacing between the holes in the tabs and the body of the enclosure will limit what style tool can be used to tighten certain fasteners. If you will be installing dual SV-EMS-220, it is acceptable to stack the two units. Follow recommended torque practices when tightening the mounting hardware. Do not rivet the SV-EMS-220 to the aircraft as this will hinder future removal if necessary.

12.2 Electrical Installation

Connect the EMS module to the SkyView network using the cabling mentioned in Section 3.4: Wire Harnesses & Network Cables or using equivalent.

Refer to Section 31 *Appendix C: Wiring and Electrical Connections* for details on connector pinouts and wire colors.



Wire the EMS Systems and Sensors according to the *103488-000 SkyView HDX Wiring Diagram - Single Engine* or the *103947-000 SkyView HDX Wiring Diagram - Twin Engine* document.

12.2.1 SkyView EMS Sensor Definition and Configuration Files

The SkyView EMS utilizes a file to define sensor behavior and a file to map those sensors to pins on the SV-EMS-220 and configure the sensors' onscreen visual representations or widgets. The sensor definition file is preloaded onto all SkyView displays during manufacture and may need to be updated. The sensor mapping and configuration file is not preloaded onto displays and must be downloaded and installed by the user.

Dynon Avionics provides EMS configuration files for approved single- and twin-engine airplanes to simplify the configuration effort of your EMS system. These files are generic, but will generate the FAA approved EMS widget styles, colors, and organizational layout of the Bottom Band, 50% and 100% display pages. These files will also map the sensors to EMS pins. These files do not include the numerical values for the color ranges. Numerical values need to be entered by the installer during initial system setup. For more information, see Section 12.6 EMS Configuration Files.

12.2.2 SV-EMS-220 Wire Harnesses

Engine and environmental sensors and transducers are connected to the SV-EMS-220 via two (2) connectors on the module: one (1) D37M and D25F. Dynon Avionics offers premade wire harnesses which break out the pins on these connectors and it is highly recommended that installers use these wire harnesses. The table below lists these wire harnesses and their respective connections to the SV-EMS-220.

Table 17: Dynon Avionics EMS Wire Harnesses

Dynon Avionics P/N	Description	Mates with...
503424-000	EMS D37F Main Sensor Harness	SV-EMS-220 D37M
503528-000	EMS D25M EGT/CHT 4-cylinder Thermocouple Wire Harness	SV-EMS-220 D25F

A typical SV-EMS-220 installation will utilize one (1) EMS 37-pin Main Sensor Harness and one (1) of thermocouple wire harness. Choose a thermocouple wire harness based on the number of EGTs and/or CHTs that need to be monitored.



The EMS 37-pin Main Sensor Harness includes a 9-pin connector that is wired to pins 11 (Orange wire), 12 (Yellow wire), and 30 (Black wire). This connector is used for other Dynon Avionics products but is not used in SkyView installations. Thus, the 9-pin connector should be removed to use these wires for connecting sensors to the SV-EMS-220. Remove the connector by cutting the three (3) wires close to the 9-pin connector.



The EMS 37-pin Main Sensor Harness has general purpose thermocouple inputs (pins 26, 27 and pins 36, 37 respectively) for additional CHT or EGT sensors, or Turbine Inlet Temperature (TIT) sensors. If using these pins, appropriate type thermocouple wire needs to be connected to the wire harness connector. These pins accommodate both J- and K-type sensors.



All of the ground wires on the SV-EMS-220 D37 are interchangeable and can be used for any sensor that requires grounding. Additionally, one (1) of these wires needs to be grounded to the aircraft locally to provide a good ground reference for the engine sensors. Use the black ground wire connected to D37 pin 3 for this purpose.

12.2.3 Sensors Powered by SV-EMS-220

Some sensors use a 5V (pin 18; white/red wire) or 12V (pin 15; red wire) power supply provided by the SV-EMS-220 module. These outputs are designed to handle a limited amount of current. The typical Lycoming/Continental/Rotax/Jabiru installations as described in the rest of this section are designed to not exceed these current limitations. However, more complex and installations that differ significantly from these standard installations should be designed to not exceed the following current limitations:

Table 18: EMS Module Current Draw Limits for 12V (Pin 15) and 5V (Pin 18) Outputs

EMS Module Output	Pin	Output Current Limit	Wire Color	Current Draw of Sensors that Use This Output
12V	15	80mA	Red	EI Fuel Flow Sensor P/N 503380-000: 15mA UMA Differential Fuel Pressure: 10mA
5V	18	300mA (Limited by internal self-resetting fuse)	White/Red	Fluid Pressure Sensors: 5mA Absolute Pressure Sensors: 5 & 10mA 3 rd party trim and flaps position: 5mA

12.2.4 Certified Sensors

See Table 19 for a list and description of the Certified sensors available through Dynon

Table 19: Certified Sensors

Sensor Type	Qty	Dynon Avionics P/N	Description
Amps Shunt	1	503386-000	0–100 Amps, 1mV=1A
Fuel Pressure	1	503389-000 ¹	1/8-27 NPT, Kavlico 0–50 PSI Fluid Pressure (Legacy)
		503850-000 ²	1/8-27 NPT, Kavlico 0-15 PSI Fluid Pressure (Legacy)
		503983-000 ^{2,3}	1/8-27 NPT, Kavlico 0-50 PSI Fluid Pressure (Legacy)
		503851-000 ²	1/8-27 NPT, Kavlico 0-150 PSI Fluid Pressure (Legacy)
		505521-000	1/8-27 NPT, 0-15 PSI Fluid Pressure
		505521-001 ³	1/8-27 NPT, 0-50 PSI Fluid Pressure
		505521-002	1/8-27 NPT, 0-150 PSI Fluid Pressure
Manifold Air Pressure	1	503387-000 ²	Dynon 0-60 inHG Absolute Pressure (Legacy)
		504780-002 ²	1/8-27 NPT, Kavlico 0-60 inHG Absolute Pressure (Legacy)
		505522-000	1/8-27 NPT, 0-60 inHG Absolute Pressure
Oil Pressure	1	503388-000 ¹	1/8-27 NPT, Kavlico 0–150 PSI Fluid Pressure (Legacy)
		503851-000 ²	1/8-27 NPT, Kavlico 0-150 PSI Fluid Pressure (Legacy)
		505521-002	1/8-27 NPT, 0-150 PSI Fluid Pressure
Temp – CHT	4	503382-000	Type J (CHT) Thermocouple, Adjust Bayonet 3/8-24 UNF
Temp – EGT	4	503384-000	Type K (EGT) Thermocouple, 1.00"–2.25" Hose Clamp
Temp – Oil	1	503385-000	5/8-18 UNF, 100°F – 240°F
Temp – Carb Air	1	503416-000	1/4-28 UNF, -50°F – 150°F

1. As of 2020, Dynon no longer supplies the 0-50 PSI Kavlico sensor (P/N 503389-000) and 0-150 PSI Kavlico sensor (P/N 503388-000).

2. As of 2025, Dynon no longer supplies the 0-15 PSI Kavlico sensor (P/N 503850-000), 0-50 PSI Kavlico sensor (P/N 503850-000), 0-150 PSI Kavlico sensor (P/N 503851-000), Dynon 0-60 inHG sensor (P/N 503387-000), and Kavlico 0-60 inHG sensor (P/N 504780-002).

3. The 0-50 PSI sensor (P/N 505521-001), and the Kavlico 0-50 PSI sensors (P/N 503983-000, 503983-000) should only be used for fuel systems with very-specific requirements. Contact Dynon Technical Support for guidance about using these sensors.

12.2.5 Tools and Equipment Required

The following list contains commonly used tools and equipment, however some of the tools or equipment listed below may not apply to your installation:

- Wire strippers.
- 22 AWG wire.
- DSUB pin crimper.
- Faston/ring terminal crimp tool.
 - Available – <http://bandcspecialty.com> – (316) 283-8000 – part number RCT-1.
- Weather Pack crimp tool (common slip joint pliers will also work).
 - Available from <http://www.whiteproducts.com/tools.shtml>.
- #2 Phillips screwdriver.
- Flathead screwdriver.
- ¼" ID tubes, any necessary adapters, and clamps for routing manifold pressure to the sensor.
- Drill and 1/8" bit.

12.2.6 Voltmeter Inputs

Pins 1 and/or Pin 2 of the EMS D37 connector can be used to monitor voltage in your electrical system (or any other DC voltage source) from 0-30V DC. Connect either of the pins to a point in your electrical system that you wish to monitor.

12.2.7 Exhaust Gas Temperature (EGT) Sensors



Wire length of CHT/EGT harnesses supplied by Dynon Avionics is not critical. It is acceptable to cut the thermocouple (brown) wire of the CHT/EGT harness to shorten the appropriate length for your installation. It is recommended to not cut the "armored" portion of the cable near the sensor end of the CHT or EGT sensors.



The EGT wire may be extended provided that:

1. Type K thermocouple is used for the extension wire. (This is different than CHT wire.)
2. There is no temperature change across the connection between the junction that is created. For example, do not create a junction across the firewall.

If either of the above guidelines are not followed, your EGT readings will be incorrect.

Correct placement of EGT sensors on the exhaust manifold - per the engine manufacturer's guidance - is critical to obtaining accurate readings. Placement differs between engine types and even specific models. All thermocouple harnesses supplied by Dynon Avionics have each function (e.g., CHT1, EGT1) labeled on each thermocouple pair.



Consult the specific engine's manual for proper EGT locations.

12.2.7.1 Mechanical Installation

Once you have determined the appropriate EGT locations for your engine, drill 1/8" diameter holes at the specified positions in the exhaust manifold. Usually, this spot is 2 to 8 inches (50mm to 200 mm) from the cylinder. This spot should be on a straight portion of the exhaust manifold, as this provides a better fit for the hose clamps. For best results, mount all sensors the same distance from each cylinder.

- Make sure the hole is placed to ensure that the sensor does not interfere with the cowl or spark plug. Also, when making holes, keep in mind that the sensor could inhibit the ability to perform routine maintenance if placed incorrectly.
- Place sensor in exhaust manifold and secure it by tightening the clamp with a flathead screwdriver. Make sure the clamp is tight and provides a secure fit, but do not over-tighten such that visible stress is put on the pipe.

Now, plug each thermocouple wire into its corresponding wire on the thermocouple harness. Ensure that you match the wire color pairs on the harness to those on the thermocouple. All thermocouple harnesses supplied by Dynon Avionics have each function (e.g., CHT1, EGT1) labeled on each thermocouple pair.



A loose sensor could allow exhaust to leak. This can lead to carbon monoxide poisoning in the cabin and/or a potential fire. Have a knowledgeable technician inspect the installation.



The sensor can come loose during flight and could potentially meet rotating engine parts or the propeller. We suggest a safety wire to keep the sensor in place.

12.2.8 Cylinder Head Temperature (CHT) Sensors



Wire length of CHT/EGT harnesses supplied by Dynon Avionics is not critical. It is acceptable to cut the thermocouple (brown) wire of the CHT/EGT harness to shorten the appropriate length for your installation. It is recommended to not cut the "armored" portion of the cable near the sensor end of the CHT or EGT sensors.



CHT wire may be extended as well, provided that:

1. Type J thermocouple is used for the extension wire. (This is different than EGT wire).
2. There is no temperature change across the connection between the junction that is created. For example, do not create a junction across the firewall.

If either of the above guidelines are not followed, your CHT readings will be incorrect.

Dynon Avionics sells bayonet style CHT sensors used in Lycoming and Continental engines. With each sensor we sell, a bayonet adapter is included. Your specific engine manual should describe where to mount these bayonet adapters, but normally, there is a threaded hole (CHT well) near the bottom of the cylinder close to the lower spark plug. Screw the bayonet adapter into this hole. Screw the locking collar up or down the spring surrounding the sensor such that the tip of the sensor is pressed against the bottom of the CHT well when the collar is attached to the adapter. Insert the CHT sensor into the well and lock the collar to the adapter. Now, plug each thermocouple wire into its corresponding wire on the thermocouple harness. Ensure that you match the wire color pairs on the harness to those on the thermocouples.

12.2.9 Tachometer



Tachometer pulses/revolution are set in the Engine Information Wizard – SETUP MENU > HARDWARE CALIBRATION > EMS CALIBRATION > TACHOMETER CALIBRATION.

Dynon Avionics does not sell a tachometer transducer.

Depending upon existing equipment and engine type, you have a few options for connecting the tachometer inputs on the SV-EMS-220. Table 20 revisits the SV-EMS-220 pins that are compatible with RPM sources.

Table 20: SV-EMS-220 RPM Inputs

Pin	Wire Color	Function
32	White/Green	Standard RPM Input Left (10+ volts)
33	White/Blue	Standard RPM Input Right (10+ volts)
34	Blue	Low Voltage RPM Input Left (< 12 volts)
35	Green	Low Voltage RPM Input Right (< 12 volts)

See the relevant subsections below for your method. You may connect different types of signals to the two (2) different RPM inputs (e.g., p-lead to Standard RPM Left and a 12-volt transducer to Standard RPM Right).

SkyView will display RPM from either the RPM Input Left or the RPM Input Right, whichever is noticed by the SV-EMS-220 first. If the first RPM signal is lost (such as when one (1) ignition source fails, or during a routine mag check), then SkyView will display RPM from the remaining RPM signal. If your engine only provides one (1) RPM signal, connect it to one (1) of the two (2) RPM Input Left pins.

12.2.9.1 Tachometer transducer

If you have a dedicated tachometer transducer (usually with a 12-volt output), you may simply connect its output to the *Standard RPM Left* input on the SV-EMS-220. Ensure that you follow all recommendations given in the manual for your individual tachometer transducer.

12.2.9.2 P-lead pickoff (Lycoming and Continental)

If you do not have a dedicated tachometer pickoff, you must follow the instructions below.

Use the two (2) included 30 kΩ resistors (color bands: orange, black, brown, red, brown; connect in either direction) to attach left and right P-leads to the standard RPM Left and RPM Right inputs on the SV-EMS-220. Connect them as shown in the figure to the right. It is important to connect each resistor as close as possible to the spot where you tap into the P-lead. This minimizes the length of cable carrying high voltage spikes. Six (6)-cylinder Lycoming engines sometimes need more inline resistance

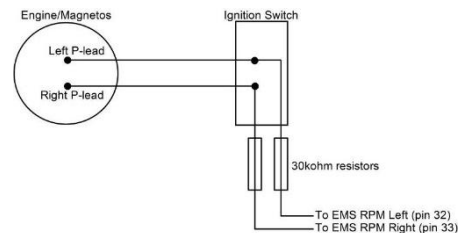

Figure 52: Magneto Pick Off

to prevent false readings by the SV-EMS-220. If you supply your own resistors, they need not be exactly 30 k Ω . Additionally, both 1/4W and 1/2W resistors are acceptable to use.



If, after setting the PULS/REV R and L values as described in the Engine Information Section, you see unstable RPM, you may need to increase the series resistance. We recommend increasing the resistance in increments of approximately 30 k Ω – approx. 30 k Ω , approx. 60 k Ω , approx. 90 k Ω , approx. 120 k Ω , and approx. 150 k Ω . Try each value *in sequence*. A higher resistance value is not necessarily "better", as too high a resistance can reduce the amplitude of the RPM signal to the point where you may see no, or low, RPM.

12.2.9.3 Other Ignition Systems

The SV-EMS-220's Standard Voltage RPM inputs can read frequency-based RPM signals, provided the peak voltages goes at least 5.1 volts above ground, and crosses back down below 2.0V relative to ground. If the peak voltage exceeds 50 volts, use the included 30 k Ω resistors as described in the P-lead pickoff (Lycoming and Continental) Section above.

For signals that have a peak voltage of 12V or lower —such as Light Speed ignition outputs—use the low voltage RPM inputs. These inputs require that the peak voltage goes at least 2.1 volts above ground, and crosses back down below 0.8V relative to ground to be counted as a pulse.

For signals that have a peak voltage of 10-12V, either the Standard or Low Voltage RPM inputs can be used.

Like the other methods above, you must know the number of pulses per revolution for your RPM transducer.

12.2.10 Manifold Pressure Sensors

The SV-EMS-220 supports the following manifold pressure sensors:

- 0-60 inHG absolute pressure (P/N 505522-000)
- Kavlico 0-60 inHG absolute pressure (P/N 50478-000) (no longer supplied as of 2025)
- Dynon 0-60 inHG absolute pressure (P/N 503387-000) (no longer supplied for SkyView products as of 2025)

For new installations, use the new 0-60 inHG absolute pressure sensor (P/N 505522-000)

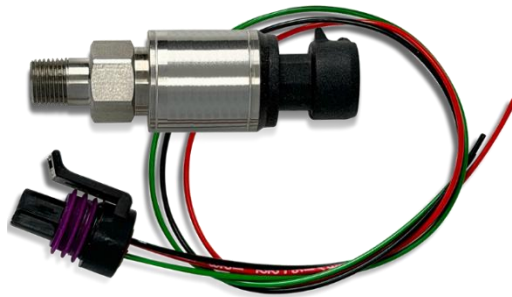

Figure 53: New 0-60 inHG Absolute Pressure Sensor

Mount the manifold pressure sensor securely using an Adel clamp or other method such as a sensor mounting block on the firewall.

The pressure sensor has a 1/8-27 NPT pipe thread fitting. Use appropriate adapters and materials to remotely mount the sensor. Do not mount the sensor directly to the engine's pressure port.



Figure 54: Adel Clamps

- ⚠ DO NOT mount sensor directly to engine or other areas of high vibration. Always mount sensor remotely to minimize vibration effects.
- ⚠ DO NOT thread sensor into pressure port by plastic portion of sensor. Doing so will damage the sensor. Use a wrench on the metal hex portion of sensor to tighten.
- ⚠ The pressure port must have a pressure fitting with a restrictor hole in it. Restrictor holes minimize leakage in the event of a failure of any of the items downstream of the pressure port connection, allowing time for an emergency landing.
- ⚠ If Teflon tape or other sealant is used, ensure the sensor casing still maintains a good connection to ground.

Connect supplied sensor wiring harness to manifold pressure sensor, and then connect wires per table below.

Table 21: Manifold Pressure Sensor Wiring

Sensor Wire Color	EMS Harness Wire Color	SV-EMS-220 Pin Number	Function
Red	White / Red	18 It is acceptable to share this pin / wire with other sensors.	Power (5V)
Black	Black	Any of Pin 3, 13, 16, 17, or 30 It is acceptable to share this Ground with other sensors.	Ground
Green	Green / Red	26 Manifold pressure	Sensor Output

Note that you may need access to the SV-EMS-220's +5 Volts auxiliary supply for other sensor installations, so make allowances for breaking out the connection to other areas. Route the three wires to the location where you would like to mount the sensor.

12.2.10.1 Retrofitting Legacy Kavlico Sensor with New Sensor

The new sensor is a direct mechanical and electrical replacement for the legacy Kavlico manifold pressure sensors. Updated software sensor definitions are available from Dynon software download page.

12.2.10.2 Retrofitting Legacy Dynon Sensor with Legacy Kavlico Sensor

If you are retrofitting a legacy Kavlico sensor (i.e., using new, old stock) into a SkyView system which used the legacy Dynon manifold pressure sensor, simply mount the manifold pressure sensor as described above and connect the wires on the sensor as detailed in table above.



Figure 55: Legacy Kavlico 0-60 inHG Absolute Pressure Sensor



Before installing Kavlico sensors, reference Dynon Technical Advisory website at dynon.com/support for important information regarding Kavlico sensors sold by Dynon.

12.2.10.3 Installing Legacy Dynon Sensor

The following is guidance for installing the legacy Dynon 0-60 inHG absolute pressure sensor (i.e., using new, old stock) in SkyView.

The Dynon sensor is an assembly consisting of three pins, a rubber seal, and a connector housing. Strip 3/16" insulation off the ends of the three wires listed at right. Slide the three rubber seals onto the three wires and the pins onto the ends of the wires. Crimp the 3 included pins onto the ends of the wires, ensuring that the long tabs that cradle the rubber seal wrap around the seal (see picture at right for example). For more details on preparing and crimping the Weather Pack pins, see <http://www.whiteproducts.net/fags.shtml>.

Table 22: Manifold Pressure Sensor Pins

SV-EMS-220 Pin	Weather Pack Pin	Color	Function
18	C	White/red	+5 Volts Auxiliary It is acceptable to share this pin / wire with other sensors.
26	B	Green/red	Manifold pressure
17	A	Black	Ground

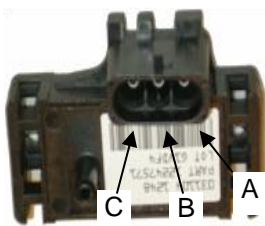

Figure 56:
Connection diagram
for sensor with all
black wires only



Figure 57: Detail
view of properly
crimped pin.

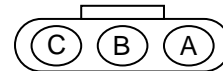

Figure 58: Pin
insertion (rear)
view of supplied
connector.

Note that you may need access to the SV-EMS-220's +5 Volts auxiliary supply for other sensor installations, so make allowances for breaking out the connection to other areas. Route the three wires to the location where you would like to mount the manifold pressure sensor.

Plug the crimped pins into the included Weatherpack connector. Now, mount the manifold pressure sensor in a secure fashion using the mounting holes on either side of the sensor.

The pressure port on the manifold pressure sensor requires 1/4" inner diameter tubing for a secure fit. You may need to use adapters to convert down to smaller inner diameter tubing for your specific engine. We recommend that you use pipe clamps at every transition point, including at the sensor itself.

12.2.11 Oil Pressure Sensors

The SV-EMS-220 supports the following oil pressure sensors:

- 0-150 PSI fluid pressure (P/N 505521-002)
- Kavlico 0-150 PSI fluid pressure (P/N 503851-000) (no longer supplied as of 2025)
- Kavlico 0-150 PSI fluid pressure (P/N 503388-000) (no longer supplied as of 2020)

For new installations, use the new 0-150 PSI fluid pressure sensor (P/N 105492-002).

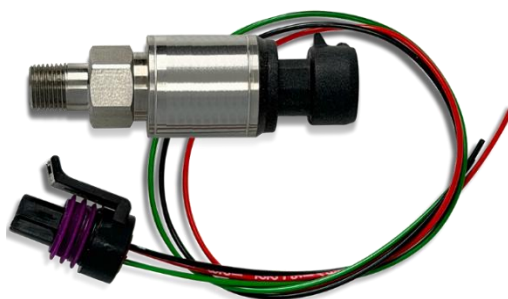



Figure 60: New 0-150 PSI Fluid Pressure Sensor

Mount the oil pressure sensor securely using an Adel clamp or other method such as a sensor mounting block on the firewall.

The pressure sensor has a 1/8-27 NPT pipe thread fitting. Use appropriate adapters and materials to remotely mount the sensor. Do not mount the sensor directly to the engine's pressure port.



Figure 59: Adel Clamps

- 

DO NOT mount sensor directly to engine or other areas of high vibration. Always mount sensor remotely to minimize vibration effects.
- 

DO NOT thread sensor into pressure port by plastic portion of sensor. Doing so will damage the sensor. Use a wrench on the metal hex portion of sensor to tighten.
- 

The pressure port must have a pressure fitting with a restrictor hole in it. Restrictor holes minimize leakage in the event of a failure of any of the items downstream of the pressure port connection, allowing time for an emergency landing.
- 

If Teflon tape or other sealant is used, ensure the sensor casing still maintains a good connection to ground.

Connect supplied sensor wiring harness to oil pressure sensor, and then connect wires per table below.

Table 23: Oil Pressure Sensor Wiring

Sensor Wire Color	EMS Harness Wire Color	SV-EMS-220/221 Pin Number	Function
Red	White / Red It is acceptable to share this pin / wire with other sensors.	18 It is acceptable to share this pin / wire with other sensors.	Power (5V)
Black	Black It is acceptable to share this Ground with other sensors.	Any of Pin 3, 13, 16, 17, or 30 It is acceptable to share this Ground with other sensors.	Ground
Green	Varies	Pin 6 (recommended) Any of Pin 4, 6, 7, 8, 9, 10, 11, 12, 20, 21, 22, 23, or 31	Sensor output

Note that you may need access to the SV-EMS-220's +5 Volts auxiliary supply for other sensor installations, so make allowances for breaking out the connection to other areas. Route the three wires to the location where you would like to mount the sensor.

12.2.11.1 Retrofitting Legacy Kavlico Sensors with a New Sensor

The new sensor is a direct mechanical and electrical replacement for the legacy Kavlico oil pressure sensors. Updated software sensor definitions are available from Dynon software download page.

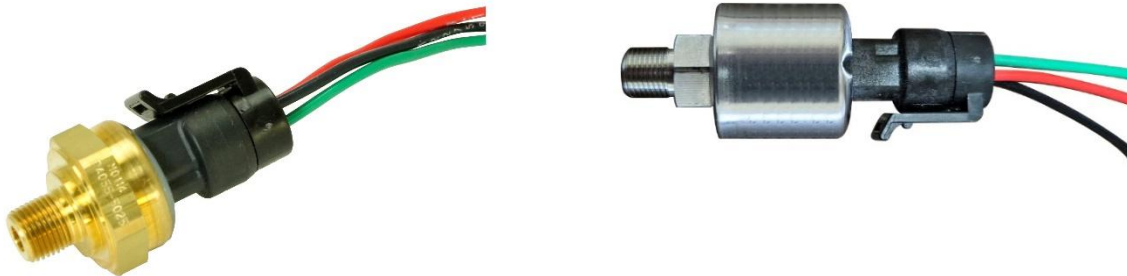

Figure 61: Legacy Kavlico 0-150 Fluid Pressure Sensors (2012-2020 (Left)) (2020-2025 (Right))

12.2.12 Oil Temperature Sensors

While a Dynon Avionics oil temperature sensor may be connected to any general-purpose input pin on the SV-EMS-220's D37, we recommend that it be connected to pin 7 on this connector.

The oil temperature sensor needs to be installed according to the directions of the engine manufacturer. Dynon Avionics sells oil temperature sensors with both 5/8-18 UNF (Dynon Avionics P/N 503385-000) and 1/8-27 NPT (Dynon Avionics P/N 503807-000) threads. Ensure that you have the right sensor for your engine.

Dynon Avionics 5/8-18 UNF Oil Temperature Sensor is furnished with an AN900-10 Crush Washer.



Figure 62: Dynon Avionics Oil Temperature Sensors



When tightening the 5/8-18 UNF Oil Temperature Sensor into place, the Crush Washer must be centered. Failure to do so may result in an improper seal.

Another option for sealing the sensor to the engine case is Earl's Stat-O-Seal Sealing Washer # 178010 installed between the sensor and the engine case.

Tighten the sensor according to your engine manufacturer's recommendations.

Route the wire from a general-purpose input pin on the EMS 37-pin Main Sensor Harness to where the oil temperature sensor is mounted. When routing the wires, make sure that they are secured, so they will not shift position due to vibration. Strip ¼" of insulation off the end of the wire. Crimp a #10 ring terminal onto the end of the wire, ensuring that a good connection is made between the wire and the connector. Unscrew the nut from the stud on the oil temperature sensor. Slip the ring terminal onto the stud and secure the nut over it.

12.2.13 Fuel Pressure Sensors

The SV-EMS-220 supports the following fuel pressure sensors:

- 0-15 PSI fluid pressure (P/N 505521-000)
- 0-50 PSI fluid pressure (P/N 505521-001)
- 0-150 PSI fluid pressure (P/N 505521-002)
- Kavlico 0-15 PSI fluid pressure (P/N 503850-000) (no longer supplied as of 2025)
- Kavlico 0-50 PSI fluid pressure (P/N 503983-000) (no longer supplied as of 2025)
- Kavlico 0-150 PSI fluid pressure (P/N 503851-000) (no longer supplied as of 2025)
- Kavlico 0-50 PSI fluid pressure (P/N 503389-000) (no longer supplied as of 2020)

For new installations, select the appropriate sensor for the airplane's fuel system:

- Use the new 0-15 PSI fluid pressure sensor (P/N 505521-000) for most carbureted fuel systems with 0.6–15 PSI requirements.
- Use the new 0-150 PSI fluid pressure sensor (P/N 505521-002) for most injected fuel systems with 6–150 PSI requirements.
- Use the new 0-50 PSI sensor (P/N 505521-001) for fuel systems with 2–50 PSI requirements.



The 0-50 PSI fluid pressure sensor (P/N 505521-001), and the legacy Kavlico 0-50 PSI fluid pressure sensors (P/N 503983-000, 503389-000) should only be used for fuel systems with very-specific requirements. Contact Dynon Technical Support for guidance about using these sensors.

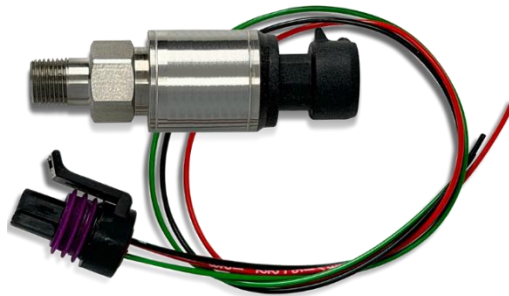



Figure 63: Fluid Pressure Sensor (0-15 PSI Shown, Others Similar in Appearance)

Mount the fuel pressure sensor securely using an Adel clamp or other method such as a sensor mounting block on the firewall.

The pressure sensor has a 1/8-27 NPT pipe thread fitting. Use appropriate adapters and materials to remotely mount the sensor. Do not mount the sensor directly to the engine's pressure port.



Figure 64: Adel Clamps

- 

DO NOT mount sensor directly to engine or other areas of high vibration. Always mount sensor remotely to minimize vibration effects.
- 

DO NOT thread sensor into pressure port by plastic portion of sensor. Doing so will damage the sensor. Use a wrench on the metal hex portion of sensor to tighten.
- 

The pressure port must have a pressure fitting with a restrictor hole in it. Restrictor holes minimize leakage in the event of a failure of any of the items downstream of the pressure port connection, allowing time for an emergency landing.
- 

If Teflon tape or other sealant is used, ensure the sensor casing still maintains a good connection to ground.

Connect supplied sensor wiring harness to fuel pressure sensor, and then connect wires per table below.

Table 24: Fuel Pressure Sensor Wiring

Sensor Wire Color	EMS Harness Wire Color	SV-EMS-220/221 Pin Number	Function
Red	White / Red It is acceptable to share this pin / wire with other sensors.	18 It is acceptable to share this pin / wire with other sensors.	Power (5V)
Black	Black It is acceptable to share this Ground with other sensors.	Any of Pin 3, 13, 16, 17, or 30 It is acceptable to share this Ground with other sensors.	Ground
Green	Varies	Pin 8 (recommended). Any of Pin 4, 6, 7, 8, 9, 10, 11, 12, 20, 21, 22, 23, or 31	Sensor output

Note that you may need access to the SV-EMS-220's +5 Volts auxiliary supply for other sensor installations, so make allowances for breaking out the connection to other areas. Route the three wires to the location where you would like to mount the sensor.

12.2.13.1 Retrofitting Legacy Kavlico Sensors with New Sensors

The new sensors are a direct mechanical and electrical replacement for the legacy Kavlico fuel pressure sensors. Updated software sensor definitions are available from Dynon software download page.

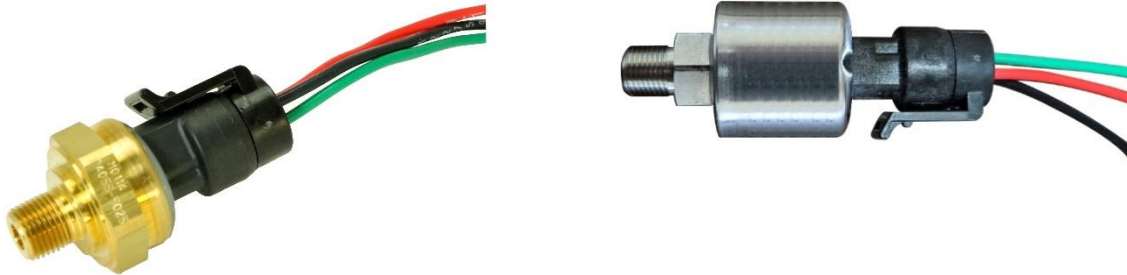

Figure 65: Legacy Kavlico Fluid Pressure Sensors (2012-2020 (Left)) (2020-2025 (Right))

12.2.14 Fuel Flow Transducer



The approximate pulses/gallon for the Fuel Flow Sensor is 68,000 (17,963.70 pulses/liter). You must configure the fuel flow transducer using this numerical value in the Sensor Setup Menu (SETUP MENU > HARDWARE CALIBRATION > EMS CALIBRATION > FUEL FLOW CALIBRATION). More information on this topic is discussed in the Fuel Computer Configuration section of this section.

Table 25: Fuel Flow Transducer Connections

Wire Color	EMS Harness Wire Color	EMS Harness Pin Number	Function
Black	Black	Any of Pins 3, 13, 16, 17, or 30	Ground
Yellow or White	Yellow	14	Fuel Flow Input 1(From fuel tank)
Red	Red (shareable with other sensors)	15 (share-able with other sensors)	+12 Volt Auxiliary
Yellow or White	White / Black	19	Fuel Flow Input 2 (optional return to tank)

12.2.14.1 General Placement Recommendations for Fuel Flow Transducer

- Do not install the fuel flow transducer, hoses and fittings near exhaust system or turbocharger. Excessive heat can damage fuel system components.
- Do not install 90-degree fittings (elbows) on the input or output of the fuel flow transducer. Doing so will cause turbulence in the fuel flow which causes inaccurate fuel flow data.
- Install the fuel flow transducer with the three (3) wires pointed UP.
- Install a fuel filter upstream of the fuel flow transducer to screen out debris.
- For best measuring performance, the fuel should travel uphill by one (1) to two (2) inches (2.54-5.08 cm) after leaving the fuel flow transducer.
- Placement of the fuel flow transducer is dependent upon other components in the fuel system and is ultimately determined by the installer. It is common to place the transducer downstream of the last fuel pump.



Due to vibration issues, never connect the fuel flow transducer directly to the engine.



When sealing the fittings on the fuel flow transducer, *do not use Teflon tape!* Instead, use a sealant such as "United EZ-Turn Fuel Resistant Lubricant" or "Permatex Thread Sealant."

12.2.14.2 Mechanical Installation

The fuel flow transducer has ¼" (6.35 mm) female NPT ports. Do not exceed a torque of 300 inch-lbs. (.112 Nm) when installing fittings into the transducer. The transducer should NOT be installed with its wires pointing DOWN (the best situation is with the wires pointing UP). The fuel line on the outlet port should not drop down after exiting the transducer - this configuration can trap bubbles in the transducer, causing jumpy readings. The inlet port, outlet port, and flow direction are marked on the top of the transducer.

12.2.15 Fuel Level Sensor

Dynon Avionics does not sell fuel level sensors.

12.2.15.1 Resistive Fuel Level Sensors

You may connect as many resistive fuel level sensors to the SV-EMS-220 to General Purpose (GP) input – any of Pins 4, 7, 9, 10, 11, 12, 20, 21 (that are not already in use). We recommend not using Pins 6, 8, 22, and 23, and 31 for fuel level sensors as these pins are used for some specialized functions. *We recommend that Pins 20 and 21 of the SV-EMS-220 D37 be used for fuel level sensors before using other general-purpose inputs.*

If you use a General-Purpose Input other than Pins 20 and 21, you must configure the pin you use: SETUP MENU > EMS SETUP > SENSOR INPUT MAPPING > C37 Pxx.

- FUEL LEVEL (RESISTIVE) – averages changes in fuel level over 1.5 minutes, with most of the change occurring within the first minute). This is a change from previous versions of this setting and is the default setting.
- FUEL LEVEL (RESISTIVE FASTER RESPONSE) – averages changes in fuel level over 15 seconds, with most of the change occurring within the first seven (7) seconds.
- FUEL LEVEL (RESISTIVE SLOWER RESPONSE) – averages changes in fuel level over seven (7) minutes, with approximately 2/3 of the change occurring within the first three (3) minutes.

Choose the option which provides your preferred responsiveness to actual fuel level changes. For example, FUEL LEVEL (RESISTIVE SLOWER RESPONSE) might be preferred for an acrobatic aircraft where the (measured) fuel level changes rapidly in maneuvers that would otherwise trigger a low fuel level alert.

12.2.15.2 Capacitive Fuel Level Sensors

Capacitive fuel level sensors such as those made by Princeton Electronics are only supported on pins 8, 22, 23, and 31 on the SV-EMS-220 D37. Capacitive sensors must output a variable voltage within the ranges of 0-5 volts DC.



First, connect the sensor with power according to the manufacturer's instructions. If the capacitive fuel level sensor requires its own calibration, perform that calibration *before* performing the SkyView fuel level calibration.

Configure the pin you use:

SETUP MENU > EMS SETUP > SENSOR INPUT MAPPING > C37 Pxx (8, 22, 23, or 31).

You can choose the following options under SENSOR:

- FUEL LEVEL (CAPACITIVE) – averages changes in fuel level over a few minutes. This is a change from previous versions of this setting.
- FUEL LEVEL (CAPACITIVE SLOWER RESPONSE) – averages changes in fuel level over approximately 3x the time of FUEL LEVEL (CAPACITIVE).

Choose the option which provides your preferred responsiveness to actual fuel level changes. For example, FUEL LEVEL (CAPACITIVE SLOWER RESPONSE) might be preferred for an acrobatic aircraft where the (measured) fuel level changes rapidly in maneuvers that would otherwise trigger a low fuel level alert.



If your electrical system / startup procedure applies power to SkyView before applying power to the capacitive fuel level sensors, when first powered up, SkyView will "sense" a fuel level of 0. If the FUEL LEVEL (CAPACITIVE SLOWER RESPONSE) is selected, the fuel level will not display the actual fuel level for as long as 7 minutes after applying power. You can either change your startup procedure to apply power to the capacitive fuel level sensors before applying power to SkyView or select FUEL LEVEL (CAPACITIVE).

Note that default fuel level sensor type is resistive fuel level sensors. To use capacitive fuel level sensors instead of resistive fuel level sensors requires changes to EMS settings in a few places. First, change the pins used for fuel quantity via the SETUP MENU > EMS SETUP > SENSOR INPUT MAPPING... menu. Then, in SETUP MENU > EMS SETUP > SCREEN LAYOUT EDITOR, delete the default fuel quantity widgets from the 20%, 50%, and 100% layouts. Finally, add the new fuel level widget(s) that will be available for the capacitive fuel level sensors.



After installation, prior to use, fuel level sensors must be calibrated before they can display accurate fuel levels. Until you have performed a fuel level calibration, the fuel level sensor widget will not display fuel levels, and will display **CAL ?**

If you have installed capacitive fuel level sensors, and these sensors require their own calibration, perform that calibration *before* performing the SkyView fuel level calibration.

To perform a fuel level calibration, go to SETUP MENU > HARDWARE CALIBRATION > EMS CALIBRATION > FUEL TANK xxx CALIBRATION > (one (1) more right click) and follow the on-screen instructions to perform the fuel level calibration. Generally, you will be prompted to perform up to ten (10) fuel level pours of equal volume; the volume of each pour will be determined by the size of the tank that you input.

For an accurate fuel level calibration, it is important to follow the on-screen instructions exactly. For example, pushing the NEXT button before a fuel pour is completed, or pushing it twice for one (1) fuel pour, will result in an inaccurate calibration, and the fuel level calibration procedure will likely have to be repeated.



Once a capacitive fuel level sensing system is calibrated for a certain type of fuel, *only that fuel should be used*, and the aircraft should be placarded for such. For example, ethanol has a dielectric constant much different than 100LL or Auto Fuel. If your capacitive fuel level sensor has been calibrated for 100LL, and you then use Auto 10% Ethanol in the tanks, the fuel level indications could be off significantly.

12.2.16 Ammeter Shunt

The following diagram shows the mounting dimensions of the Ammeter Shunt.

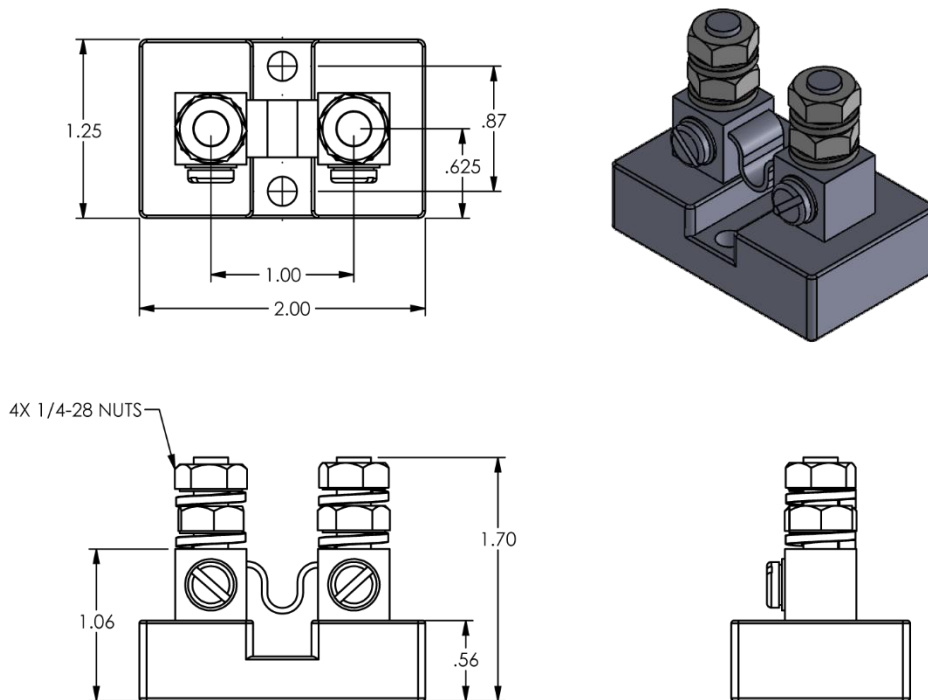

Figure 66: Ammeter Shunt (100A)

The ammeter shunt should be mounted so that the metal part of the shunt cannot touch any part of the aircraft. The ammeter shunt can be installed in your electrical system in one of three locations as shown in the figure below.

- Position A – Ammeter indicates current flow into or out of your battery. In this position, it will show both positive and negative currents.
- Position B – Ammeter indicates only the positive currents flowing from the alternator to both the battery and aircraft loads.
- Position C – Ammeter indicates the current flowing only into the aircraft loads.



Note that the ammeter shunt is not designed for the high current required by the starter and must not be installed in the electrical path between the battery and starter.

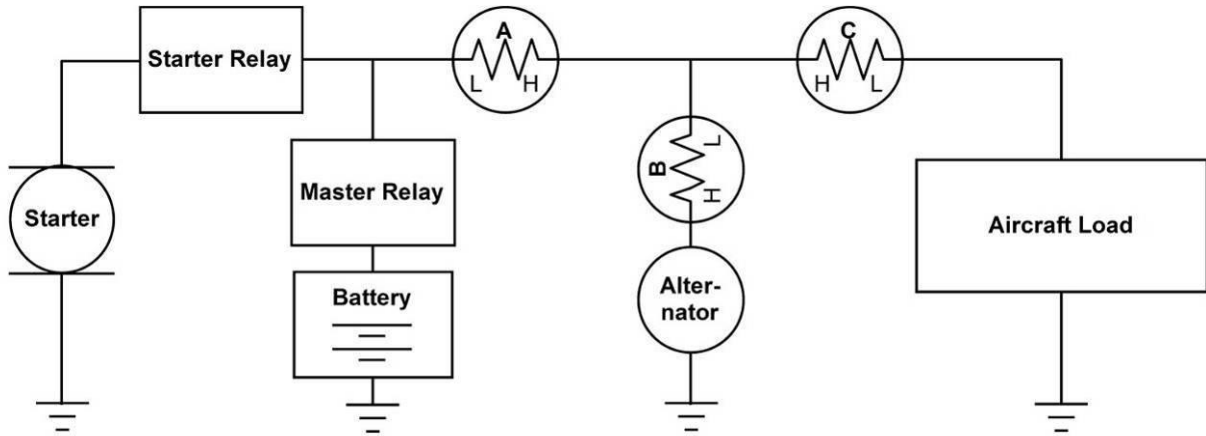

Figure 67: Recommended Amps Shunt Locations (simplified electrical diagram)

Use two (2) ¼" (6.35 mm) ring terminals sized appropriately for the high-current wire gauge you will be routing to and from the ammeter shunt. Cut the wire where you would like to install the ammeter shunt. Strip the wire and crimp on the ring terminals. Using a Phillips screwdriver, remove the two (2) large screws (one (1) on either end of the shunt), slip the ring terminals on, and screw them back into the base.

Table 26: AMPS SHUNT Pins

Pin	Color	Function
24	Orange/green	AMPS High
25	Orange/violet	AMPS Low

We highly recommend that you fuse both the connections between the shunt and the SV-EMS-220 by connecting a 1-amp fuse in-line between the shunt and the SV-EMS-220 on each Amps High and Amps Low signal wire.

Crimp the two (2) supplied #8 ring terminals onto the Amps High and Amps Low leads (pins 24 and 25) on the EMS 37-pin Main Sensor Harness. Unscrew the two (2) smaller screws on the ammeter shunt. Slide the ring terminals onto them and screw them back into the base. Connect the "Amps High" lead to the side of the shunt marked by "H"; connect the "Amps Low" lead to the side marked by "L."

If you find that the current reading displayed on the EMS page is the opposite polarity of what you want, swap the two (2) signal inputs (Amps High and Amps Low) to obtain the desired result.



It is extremely important that you secure all loose wires and ensure that exposed terminals cannot touch or short out to other objects in the plane. All metal on the shunt is at the same voltage as—and carries the same risks as—the positive terminal on the battery. Improperly installing the ammeter shunt can result in high current flow, electrical system failure, or fire.

12.2.17 Carburetor Temperature Sensor

The carburetor temperature sensor may be connected to any general-purpose input pin on the SV-EMS-220's D37, however, we recommend that it be connected to pin 23 on this connector.

Install the carburetor temperature sensor in the venturi area at the point where ice first begins to form. This is located after the main nozzle before the throttle valve. You must remove the plug in the carburetor housing below the throttle valve. On four (4)-cylinder engines which use the Marvel Schebler MA-3 carburetors, this plug is located on the forward side. On six (6)-cylinder engines using the MA-4 carburetor, the plug is located on the rear. If your carburetor is not drilled and tapped for the plug, you must remove the carburetor from the engine and drill out the lead plug in the appropriate spot. Tap the hole with a ¼-28 tap. Remove all chips and burrs before reinstalling.

Route either of the two (2) wires to an electrical ground on the SV-EMS-22X D37 connector. Route the other wire to the general-purpose input of your choice.

12.2.18 Trim and Flaps Position Potentiometers

Trim and flap indicators may not be available on all airplanes. Only airplanes equipped with flap and trim position sensors can display these positions on EMS

Position potentiometers may be connected to any general purpose input pin on the SV-EMS-220's D37 and must be calibrated according to the instructions found in *Section 12.7.10: EMS Sensor Calibration*

The number of position potentiometers in any installation is limited by the number of unused general purpose input pins on the SV-EMS-220's D37 connector. The tables in the Example Engine Sensor and Transducer Installations Section contain recommended input pins for position potentiometers.

Dynon Avionics does not sell trim or flaps position sensors. These are normally included with, or added onto, their respective servos.

Most flap and trim sensors are potentiometers (variable resistors) which require power and ground inputs and supply an output that is a function of position. These potentiometers come in a variety of resistance ranges, but are typically 1 kΩ, 5 kΩ, 10 kΩ, and 20 kΩ. All of these values will work properly with the SV-EMS-220, as there is a calibration required. Connect Pin 18 (+5 Volts Auxiliary) from the SV-EMS-220 to the +5 Volts input on your trim/flap position sensor. Connect the ground input on the sensor to a ground common to the SV-EMS-220's signal ground. Connect the output of the sensor to the desired general-purpose input. For physical installation, refer to the instructions that came with your position sensor.



Trim and flaps position potentiometers must be calibrated. Your SkyView display utilizes onscreen wizards that help you do this. Go to the EMS Calibration Menu to access these wizards (SETUP MENU > HARDWARE CALIBRATION > EMS CALIBRATION).



The take-off position will be shown as a green line on the trim widget. If you do not want this marking on your trim widget, press NONE during the take-off position portion of the trim calibration.

12.2.19 General Purpose Temperature Sensor

Any temperature sensor provided by Dynon Avionics may be utilized as a general-purpose temperature sensor on any of Pins 4, 6, 7, 8, 9, 10, 11, 12, 20, 21, 22, 23, or 31 on the SV-EMS-220.

For example, you may connect an SV-OAT-340 sensor and configure it as a general-purpose thermometer (e.g., for cabin temperature). Connect one (1) of the wires to the input pin, and the other wire to any available EMS Ground, any of Pins 3, 5, 13, 16, 17, or 30.

12.2.20 Landing Gear Position Indication

See Section 12.3 Contacts.

12.3 Contacts

Contacts may be connected to any general-purpose input pin on the SV-EMS-220's D37. The number of contacts in your SkyView system is only limited to the number of unused general purpose input pins on the connector.

Dynon Avionics does not sell contacts or switches.

Contacts are used for a variety of purposes, such as monitoring canopy closure. The EMS Software reads the voltage state of general-purpose inputs. To configure them as contacts, use two (2) voltage ranges in your sensor setup. Set one (1) to 0-2V, and the other from 2-5V. SkyView will then report whether each input is open (no connection to ground, which is the 2-5V state) or closed (connection to ground, which is the 0-2V state). You must ensure that when closed, the contact connects to a ground common to the SV-EMS-220. The voltage on the general-purpose inputs should not exceed 5 volts, but the inputs are protected against spikes up to 30V. If a general-purpose input is used to monitor a voltage above 5V, such as monitoring whether power is connected to a 12V fuel pump, a 10 Kilo-ohm resistor in series with the positive voltage sense wire must be installed.



General purpose input pins are 0–5-volt inputs. While higher voltages are momentarily tolerated, the voltage will not read higher than 5 volts.

Contacts Used for Retractable / Amphibious Landing Gear and Related Alerts

The simplest method to monitor landing gear state is to use a contact as there are only two (2) states to monitor and it is mechanically and electrically easiest to install. To enable audio alerts related to landing gear status, the contact used for monitoring the status of landing gear must be named GEAR 1, GEAR 2, GEAR 3, or GEAR 4:

SETUP MENU > EMS SETUP > SENSOR INPUT MAPPING > C37 Pxx >
> FUNCTION: CONTACT
> SENSOR: CONTACT
> NAME: GEAR 1

To configure the GEAR contact alert for retractable landing gear:

- Install the GEAR contact that when the landing gear is up, the state of the contact is "UP" and when the landing gear is down, the state of the contact is "DOWN".
- SETUP MENU > AIRCRAFT INFORMATION:
 - > LANDING GEAR TYPE: RETRACT
 - > LANDING GEAR CHECK SPEED: (set as appropriate for your plane)
 - > LANDING GEAR OVERSPEED: (set as appropriate for your plane)

To configure the GEAR contact alert for amphibious landing gear:

- Install the GEAR contact that when the amphibious landing gear is configured for landing on water, the state of the contact is WATR and when the amphibious landing gear is configured for landing on land, the state of the contact is LAND.
- SETUP MENU > AIRCRAFT INFORMATION:
 - > LANDING GEAR TYPE: AMPHIB
 - > LANDING GEAR CHECK SPEED: (set as appropriate for your plane)
 - > LANDING GEAR OVERSPEED: (set as appropriate for your plane)
- SETUP MENU > SYSTEM SETUP > AUDIO SETUP > LANDING GEAR > VOICE

12.4 General Purpose Thermocouple

You may configure the SV-EMS-220 to monitor two (2) J or K type thermocouples in addition to the twelve thermocouples available on the SV-EMS-220's D25 connector. Dynon Avionics does not supply a specific general purpose thermocouple sensor for this purpose. However, our standard EGT and CHT sensors will work, as will any other J or K type thermocouple.

The following table revisits which SV-EMS-220 pins are compatible with general purpose thermocouples.

Table 27: SV-EMS-220 D37 General Purpose Thermocouple Pins

Pin	Wire Color	Function
27	Not supplied	General Purpose TC Input 1+
28	Not supplied	General Purpose TC Input 1-
36	Blue	General Purpose TC Input 2+
37	Green	General Purpose TC Input 2-



If you use the second general purpose thermocouple input on pins 36 and 37, it is necessary to remove the blue and green wires from these pins on the EMS 37-pin Main Sensor Harness.

Dynon Avionics sells both J and K type thermocouple wire which may be used to connect the desired thermocouple to the SkyView. Ensure you order the correct wire type for the thermocouple you intend to use. Crimp a Female DSUB pin on the end of each wire and plug them into the SV-EMS-220's EMS 37-pin Main Sensor Harness D37. Polarity is important, so ensure that you are routing the positive side (yellow for K-type; white for J-type) of the thermocouple to pin 27 or pin 36 on the 37-pin harness, and the negative side to pin 28 or pin 37.

12.5 Engine Information

Use the Engine Information Wizard (SETUP MENU > EMS SETUP > ENGINE INFORMATION) to specify engine type, horsepower rating, redline and cruise RPM, and set HOBBS and TACH time (if installation is in a non-zero-time engine).

If you have an engine type that is in the list, please choose the appropriate engine. This will allow the system to perform some calculations that are specific to that engine, such as % power (Lycoming / Continental only) and special operating limitations (Rotax only). If your engine is not listed, choose "Other."

Horsepower is used to do some of the % power calculations (Lycoming/Continental engines only) and the auto Rich-of-Peak and Lean-of-Peak detection. Set it to the engine manufacturer's rated HP for initial usage. You may need to adjust this number in order to get all calculations working correctly.

If you are getting an auto Lean-of-Peak indication that is coming on too early, before the engine actually peaks while leaning, lower this number. It is not meant to be a measure

of actual horsepower produced, as engines that are more efficient will act as if they are lower horsepower in the calculation. This will be particularly true if you are running a higher compression ratio than the stock charts are based upon.

Cruise RPM is used when calculating tach time. Tach time is a measure of engine time normalized to a cruise RPM. If you spend one (1) hour at your cruise RPM, tach time will increment one (1) hour. If you spend one (1) hour at 1/2 your cruise RPM, tach time will only increase by 1/2 hour. Tach time is defined as $TIME \times (CURRENT\ RPM / CRUISE\ RPM)$.

Hobbs time is a simple timer that runs whenever the oil pressure is above 15 PSI or the engine is above 0 RPM.

INHIBIT ENGINE ALERTS AT BOOT: NO | YES

When set to YES, all engine alerts, both audio and visual, will occur until after the first engine start, or 5 minutes, whichever comes first. This option can help inhibit nuisance alarms before the engine is started. When set to NO, engine alerts are always active.

ALARM LIGHT: SOLID AFTER ACK | OFF AFTER ACK

If you have connected an External Alarm Light to SV-EMS-220 pin 29, the Alarm Light setting determines how the light behaves after alarm acknowledgement. It can be set to either SOLID AFTER ACK, which leaves the light lit continuously after acknowledgement (until the alarm condition ceases) or OFF AFTER ACK, which turns the light off after an alarm has been acknowledged.

12.6 EMS Configuration Files

Dynon Avionics provides EMS configuration files for approved single- and twin-engine airplanes to simplify the configuration effort of your EMS system. These files are generic, but will generate the FAA approved EMS widget styles, colors, and organizational layout of the Bottom Band, 50% and 100% display pages. These files will also map the sensors to EMS pins.

The installer is required to configure the color bands to correspond with the engine limitations that are published in the airplane flight manual.

It is imperative that your airplane's sensors have been wired according to the *103488-000 SkyView HDX Wiring Diagram - Single Engine* or the *103947-000 SkyView HDX Wiring Diagram - Twin Engine* document for these files to work correctly.

12.7 EMS Sensor Input Mapping



In order to save installers time, Dynon Avionics provides preconfigured sensor mapping and settings files which support four- and six-cylinder engine installations, providing the airplane has been wired according to the *103488-000 SkyView HDX Wiring Diagram - Single Engine* or the *103947-000 SkyView HDX Wiring Diagram - Twin Engine* document available for download at dynoncertified.com/docs.



Settings for SV-EMS-220 pin mapping, ranges, widget graphical properties, etc. are automatically shared between multiple SkyView displays.

Before beginning to configure your EMS system, load the appropriate EMS configuration file for the engine cylinder count (4-cylinder/6-cylinder) and engine count installed on your airplane onto your SkyView HDX displays using the instructions found in Section 27.5.3. After the file is loaded, modify the sensor settings according to the Airplane Flight Manual for your airplane using the Sensor Setup menu (SETUP MENU > EMS SETUP > SENSOR SETUP).

Note that it is critical that you should check every setting before operating your engine with them as these files are only a starting point. While efforts were made to set up temperature, pressure, and other ranges to reasonable starting points, Dynon Avionics makes no claim that they are correct for your engine, as slightly different engines may have different limits.

Use this section as a guide when you review and update the sensor map and settings that were sourced from the preconfigured file. Also use this section if you are creating a sensor map and settings from scratch.

12.7.1 EMS Sensor Mapping Explanation

The SkyView system must be configured to map SV-EMS-220 pin numbers to physical sensors. This section contains an explanation of what it means to define a sensor for mapping purposes and contains instructions on how to map sensors mentioned in this section to pins on the SV-EMS-220. Mapping can be accomplished using two (2) methods: you can use a premade file as mentioned above or you can manually map engine sensors to EMS module pins.

All sensors and transducers are mapped in the Sensor Input Mapping Wizard. As mentioned earlier, some pins are compatible with a variety of sensors, while other pins have fixed functionality. A sensor is defined in the Sensor Input Mapping Wizard by the following parameters:

- Pin # – pin or set of pins the sensor is connected to.
- Function – what the sensor measures (e.g., pressure and temperature).
- Sensor – actual sensor part used, for example 150 PSI Fluid Pressure (505521-002).
- Name – six-character field that names the sensor for use by the pilot in flight.

The table below shows an example oil pressure sensor map on pin 6 of the SV-EMS-220 D37 connector.

Table 28: Example Sensor Map

PIN #	FUNCTION	SENSOR	NAME
C37 P6	PRESSURE	150 PSI FLUID PRESSURE (505521-002)	OIL

12.7.2 Manual Sensor Mapping



Appendix D: SV-EMS-220 Sensor Input Mapping Worksheet is a useful tool during sensor mapping. This section is intended for use only if the premade sensor mapping file does not contain the sensor definitions needed for your installation.

Go to the Sensor Input Mapping Wizard (SETUP MENU > EMS SETUP > SENSOR INPUT MAPPING...) and use the following procedure to manually map a sensor or transducer:

1. Scroll through the different parameters using a combination of knob turns and movements in the up, down, left, and right motions. The selected parameter is highlighted, and its text is enlarged.
2. Press SELECT to open the parameter for editing.
3. Edit the parameter using a series of knob turns and movements.
4. Save the parameter edit by pressing ACCEPT or by moving either knob to the right or the left. Press CANCEL to back out of the parameter edit mode without saving.

12.7.3 EMS Sensor Settings

Mapped sensors that are displayed on the Engine Page should have their alert and graphical properties appropriately configured. This section explains the settings that are required for EMS sensors, contains instructions for manually configuring sensor settings, and uses several sensor settings examples to further explain sensor settings.

SkyView EMS sensor settings are defined by the following parameters in the Sensor Setup Menu:

- ALARM.
- MAXIMUM GRAPHICAL DISPLAY.
- MINIMUM GRAPHICAL DISPLAY.
- SHOW SENSOR UNITS.
- RANGE (1-5).

12.7.4 EMS Sensor Alarms

EMS alerts (audio, EMS indicator light) are triggered when a sensor goes into a RED range and set to SELF-CLEAR or LATCHING below. There are three (3) alarm options for EMS sensors:

- OFF – no alarm for the sensor.
- SELF-CLEAR – When an alert is triggered, it is annunciated both on the engine page and in the messaging system. When the alert condition ceases, all of these annunciations cease, even if the precise alert message was not acknowledged by pressing the rightmost button on the display to bring up the message window.

- **LATCHING** – When an alert is triggered, it is annunciated both on the engine page and in the messaging system. However, when the alert condition ceases, the message notification area above the rightmost button will continue to show the unacknowledged alert state until the alert message is viewed in the message window, even though the offending parameter has returned to within limits. This behavior ensures that the pilot is aware that an alert was triggered, even though the condition no longer exists.

Reference the SkyView Pilot's User Guide for information regarding how sensor alarms show up onscreen during operation.

12.7.5 EMS Sensor Graphical Display Limits

These settings define the minimum and maximum values that will be shown graphically on the sensor's gauge. Effectively, this is the start and stop point of the gauge. If the indicator you choose for this value shows digital numbers for the value, they will not be limited by this setting. The system will not allow you to set these numbers higher or lower than the sensor can support.

To increase the width of the red line indications, set the graphical display limit slightly lower or higher than the limits defined in the airplane manufacturer's documentation.

12.7.6 SHOW SENSOR UNITS (YES | NO)

Some custom developed sensors may warrant a graphical widget that is not expressed in any of the units that SkyView's EMS supports. In such cases, you can suppress the display of the widget's actual unit of measurement (volts, degrees, etc.) by setting SHOW SENSOR UNITS to NO.

12.7.7 EMS Sensor Ranges

According to *AC 20-88A Guidelines on the Marking of Powerplant Instruments* the following colors have very specific meanings, and therefore shall only be used as stipulated by the airplane manufacturer's documentation:

- Red indicates an operating condition beyond authorized limits and requires a specific action on the part of the flight crew. The specific action to be taken should be described in the airplane manufacturer's documentation.
- The color yellow is used to indicate a cautionary range where limited operation is permissible as directed by the airplane manufacturer's documentation. An example of compliance with the precautionary range requirement is the yellow arc marking on the carburetor air temperature gauge to indicate the range of temperature where carburetor icing may occur.

- Green is used to indicate a normal condition for operation, both ground and flight. Where applicable, the high value end of the green arc should indicate the maximum limit for normal operation, and the low value end of the green arc should indicate the minimum limit for normal operation. Where appropriate, there may be blank gaps, or other colors, inserted into the green arc. Either the upper or lower end of the green arc may extend to the red radial or stop short of it as appropriate to the measurement being marked. A wide green arc and a narrow green arc may be used to denote a normal all-engine range and a normal engine-out range, if appropriate.

Apply the colors and values exactly as defined in airplane manufacturer's documentation. In some case, gaps may appear between the red colored limit, and the green colored normal operating range. These gap ranges, when they occur, can be colored any color you choose, except Red, Yellow, or Green.

The order that ranges are configured has no effect on the functionality or display of the gauge. Ranges are defined with the following properties: enable, color, top, and bottom. Enable is used to tell SkyView if that range is on or off. If it is off, it will not be considered or displayed.

Each gauge can consist of up to five (5) ranges. If fewer ranges are desired (such as a contact), set the unneeded ranges ENABLE: NO. Each range has an associated color: Black, Red, Orange, Yellow, Green, Blue, Violet, White, or Cyan. If a range is not defined, it is considered black, so there is not generally a reason to configure black ranges. If ranges overlap, the following rules apply:

- Red trumps Yellow.
- Yellow trumps Green.
- Green trumps Blue / Cyan / Orange / Violet / White / Yellow (these are equal priority).
- Blue / Cyan / Orange / Violet / White / Yellow (these are equal priority) trumps Black.

For example, you could set up two (2) ranges for the same gauge, each 0-10, one (1) Red, and one (1) Green, and that range would be Red. To further illustrate this behavior, if another range for that same gauge was configured from 5-15 and set to Yellow, only 10-15 would be Yellow.

The two (2) edge ranges are considered to go on "forever," so if a gauge is set up as Yellow from 10 to 20 and Red from 20 to 30, and the sensor reads 35, it will still be considered Red since that is above the highest range. It will be considered Yellow below 10. If you wish for this not to occur, you must make your edge ranges Black.

Alarms are only triggered when ALARM: SELF-CLEAR or LATCHING and the value enters a Red range on a gauge. When values enter into a Yellow range, their numerical value is highlighted in Yellow to annunciate the caution condition.

12.7.8 Fuel Computer Configuration

Setting Pulses/Gallon

To find and configure the pulses/gallon value associated with your fuel flow sensor:

The fuel flow sensor requires a starting K-VALUE of 68000 under SETUP MENU > HARDWARE CALIBRATION > EMS CALIBRATION > FUEL FLOW CALIBRATION.

Over time, you may notice that the instrument's computation of gallons or liters remaining (based on fuel flow) is either high or low. This is a result of many factors, including individual installation. To correct for this, follow this procedure:

Over several fill-ups keep a running total of the amount of fuel added. Keep a running total of the GALS (or LTRS) USED parameter over this same time span.

Perform the following calculation: $\frac{FuelUsed(computed)}{FuelFilled(actual)}$. You should obtain a number that

is close to 1. We'll call this number, FuelFlowRatio.

Now perform this calculation: $CurrentPulsesPerGallon * FuelFlowRatio$. Enter this number as your new pulses/gallon value.

Observe the results over your next tank for accuracy. Repeat the above if necessary.

The general rule of thumb: if your GALS (or LTRS) USED reads higher than you expect, *increase* the pulses/gallon; if it reads lower than you expect, *decrease* the pulses/gallon.

If your engine has a return fuel flow sensor, note that there is a second pulses/gallon setting that is mapped to a second set of input pins. When a second fuel flow sensor is connected, and the pulses/gallon is adequately set, the fuel seen returning through the second fuel flow sensor is automatically subtracted from the flow that is seen through the primary sensor. If you do not have a second fuel flow sensor, you may ignore this setting entirely.



In SETUP MENU > HARDWARE CALIBRATION > EMS CALIBRATION > FUEL FLOW CALIBRATION, if you change PULS/GAL (C37 P14) or PULS/GAL (C37 P19), for the new value to be active, you must push the ACCEPT button, then the EXIT button. Until you EXIT the menu, the changed value is not used by SkyView (despite the value being changed in the menu).

Fuel Computer Presets

Fuel Computer computations are based on measured fuel flow and the pilot's input of the aircraft's starting fuel state. SkyView offers a few settings that allow the pilot to pre-program full fuel and an optional second "preset" fuel quantity. Once programmed, typical aircraft fuel loads are then quickly recalled under in the EMS > FUEL menu as described in the Pilots User Guide.

There are three (3) fuel computer options, found under SYSTEM SETUP > SYSTEM SETUP > AIRCRAFT INFORMATION. They are only applicable if you have a fuel flow sensor installed:

- **TOTAL FUEL CAPACITY** – set this to the total usable fuel on board when the tanks are full. Once this is set, the pilot is prevented from accidentally setting more than this amount of fuel on board.
- **PRESET FUEL CAPACITY** – this can be used to quickly recall a second, non-full starting fuel state. For example, if your tanks have tabs so that you can easily fill to $\frac{3}{4}$ of your normal full fuel load, you will enter this number here so that you can quickly set your fuel computer to this second preset when you fill to the tabs.
- **FUEL ADDED DETECT** – When set to yes, SkyView will check for discrepancies between the physical fuel quantity sensors and the fuel computer's calculated fuel load on boot-up. If one (1) is found, SkyView will prompt the user to adjust the fuel computer's fuel state.
- **FUEL TANK REMINDER** – SkyView can be configured to alert the pilot to switch their fuel tanks at a set time or fuel usage interval (based on the fuel computer's fuel calculations). When enabled, it will periodically announce a "Switch Fuel Tank" alert message and audio alert. There is no visible counter for this timer. To configure this feature, set FUEL TANK REMINDER to either TIME or QUANTITY. Then, set the resulting FUEL REMINDER TIME or FUEL REMINDER AMOUNT setting to the desired reminder interval.

12.7.9 Manual EMS Sensor Setup Settings Configuration

Go to the Sensor Setup Menu (SETUP MENU > EMS SETUP > SENSOR SETUP) to manually configure the settings of an EMS sensor. Once there, a list of every mapped sensor is displayed.

Follow this basic procedure to configure sensor settings:

1. *Choose a sensor.* Scroll through the menu to a sensor and move the knob right to enter to the sensor configuration menu.
2. *Set the alarm.* Scroll to the ALARM configuration line, move the knob right to enter the Alarm Adjust Menu, choose the appropriate alarm for the sensor, and then press ACCEPT. Press BACK to return to the sensor configuration menu.
3. *Set the graphical display limits.* Scroll to the MAXIMUM and MINIMUM GRAPHICAL DISPLAY lines, move the knob right to enter the respective menus, adjust the values appropriately - and then press ACCEPT. Press BACK to return to the sensor configuration menu.
4. *Set the ranges.* Scroll the menu and configure enable, color, and top and bottom.
5. *Save the settings.* Press BACK to return to the Sensor Setup Menu. Press EXIT to return to the Main Menu.

The examples on the following pages show four (4) configured sensors: a voltmeter, a contact, RPM, and an oil temperature sensor.

12.7.9.1 Example Voltmeter Setup

Assume this sensor was mapped on the Sensor Input Mapping Wizard as:

Table 29: Example Sensor Input Mapping for C37 P1

PIN #	FUNCTION	SENSOR	NAME
C37 P1	VOLTS	VOLTAGE MEASURE	MAIN

Now, we want to configure its alert and graphical properties. Go to the Sensor Setup Menu and open the MAIN VOLTS Page (SETUP MENU > EMS SETUP > SENSOR SETUP > MAIN VOLTS).

Configure MAIN VOLTS with the following properties:

- ALARM: OFF
- MAXIMUM GRAPHICAL DISPLAY: 15.0 VOLTS
- MINIMUM GRAPHICAL DISPLAY: 10.0 VOLTS
- SHOW SENSOR UNITS YES
- RANGE 1
 - ENABLE YES
 - COLOR RED
 - TOP 11.0 VOLTS
 - BOTTOM 10.0 VOLTS
- RANGE 2
 - ENABLE YES
 - COLOR YELLOW
 - TOP 12.0 VOLTS
 - BOTTOM 11.0 VOLTS
- RANGE 3
 - ENABLE YES
 - COLOR GREEN
 - TOP 13.6 VOLTS
 - BOTTOM 12.0 VOLTS
- RANGE 4
 - ENABLE YES
 - COLOR YELLOW
 - TOP 14.6 VOLTS
 - BOTTOM 13.6 VOLTS
- RANGE 5
 - ENABLE YES
 - COLOR RED
 - TOP 15.0 VOLTS
 - BOTTOM 14.6 VOLTS

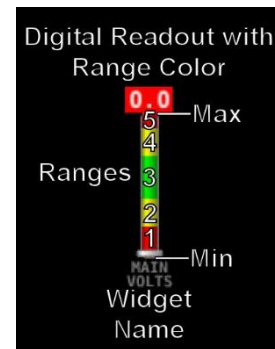

Figure 68: Anatomy of a Widget, Main Volts

12.7.9.2 Example Contact Sensor Setup

Assume this sensor was mapped on the Sensor Input Mapping Wizard as:

Table 30: Example Sensor Input Mapping for C37 P9 (as a Contact)

PIN #	FUNCTION	SENSOR	NAME
C37 P9	CANOPY	CONTACT	CANOPY

Now, we want to configure its alert and graphical properties. Go to the Sensor Setup Menu and open the CANOPY CONTACT Page (SETUP MENU > EMS SETUP > SENSOR SETUP > CANOPY CONTACT).



Note that although inputs set up as contacts can physically accept up to 15V (so that they can accept nominal aircraft voltage as one (1) of their two (2) states), and up to 30V DC as a brief surge, without damaging the input. However, the maximum the EMS can measure is 5.0V. This means that as depicted below, the two (2) measured ranges should be set to 0-2.5V and 2.5-5V to measure the absence and presence of power.



Canopy Contact is a special case input. If a configuration file is loaded containing:

canopy_warn_rpm=XXXX (where that's something between 0 and 9999) then the audio warning "Check Canopy Latch" will play if the engine RPM exceeds the specified RPM level and the canopy input is in the open state. One (1) may generate a .dfg file with only this line, place it on an USB flash drive and load it in SETUP MENU > SYSTEM SOFTWARE > LOAD FILES.

Configure CANOPY CONTACT with the following properties:

- ALARM: OFF
- MAXIMUM GRAPHICAL DISPLAY: 5.0 VOLTS
- MINIMUM GRAPHICAL DISPLAY: 0.0 VOLTS
- RANGE 1
 - ENABLE YES
 - NAME OPEN
 - COLOR RED
 - TOP 5.0 VOLTS
 - BOTTOM 2.5 VOLTS
- RANGE 2
 - ENABLE YES
 - NAME CLOSED
 - COLOR GREEN
 - TOP 2.5 VOLTS
 - BOTTOM 0.0 VOLTS
- RANGE 3
 - ENABLE NO
 - NAME R3
 - COLOR GREEN
 - TOP 20.0 VOLTS
 - BOTTOM 10.0 VOLTS

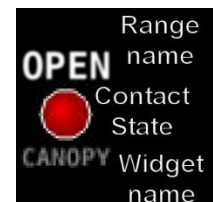

Figure 69:
Anatomy of a
Widget,
Canopy
Contact

- RANGE 4
 - ENABLE NO
 - NAME R4
 - COLOR YELLOW
 - TOP 10.0 VOLTS
 - BOTTOM 5.0 VOLTS
- RANGE 5
 - ENABLE NO

12.7.9.3 Example RPM Setup

Assume this sensor was mapped on the Sensor Input Mapping Wizard as:

Table 31: Example Sensor Input Mapping for C37 P32/34 (RPM / Tachometer)

PIN #	FUNCTION	SENSOR		NAME
C37 P32/34	RPM	RPM		RPM

Now, we want to configure its alert and graphical properties. Go to the Sensor Setup Menu and open the RPM Page (SETUP MENU > EMS SETUP > SENSOR SETUP > RPM RPM).

Configure RPM with the following properties:

- ALARM: OFF
- MAXIMUM GRAPHICAL DISPLAY:3000 RPM
- MINIMUM GRAPHICAL DISPLAY:0 RPM
- SHOW SENSOR UNITS YES
- RANGE 1
 - ENABLE YES
 - COLOR GREEN
 - TOP 2000 RPM
 - BOTTOM 0 RPM
- RANGE 2
 - ENABLE YES
 - COLOR YELLOW
 - TOP 2250 RPM
 - BOTTOM 2000 RPM
- RANGE 3
 - ENABLE YES
 - COLOR GREEN
 - TOP 2700 RPM
 - BOTTOM 2250 RPM
- RANGE 4
 - ENABLE YES
 - COLOR YELLOW
 - TOP 2750 RPM
 - BOTTOM 2700 RPM
- RANGE 5
 - ENABLE YES
 - COLOR RED
 - TOP 3000 RPM
 - BOTTOM 2750 RPM



Figure 70: Anatomy of a Widget, RPM

12.7.9.4 Example Oil Temperature Sensor Setup

Assume this sensor was mapped on the Sensor Input Mapping Wizard as:

Table 32: Example Sensor Input Mapping for C37 P7 (Oil Temp)

PIN #	FUNCTION	SENSOR	NAME
C37 P7	TEMPERATURE	150 PSI FLUID PRESSURE (505521-002)	OIL

Now, we want to configure its alert and graphical properties. Go to the Sensor Setup Menu and open the OIL TEMPERATURE Page (SETUP MENU > EMS SETUP > SENSOR SETUP > OIL TEMPERATURE).

Configure OIL TEMPERATURE with the following properties:

- ALARM: LATCHING
- MAXIMUM GRAPHICAL DISPLAY: 260 °F
- MINIMUM GRAPHICAL DISPLAY: 80 °F
- SHOW SENSOR UNITS YES
- RANGE 1
 - ENABLE YES
 - COLOR YELLOW
 - TOP 165 °F
 - BOTTOM 80 °F
- RANGE 2
 - ENABLE YES
 - COLOR GREEN
 - TOP 220 °F
 - BOTTOM 165 °F
- RANGE 3
 - ENABLE YES
 - COLOR YELLOW
 - TOP 240 °F
 - BOTTOM 220 °F
- RANGE 4
 - ENABLE YES
 - COLOR RED
 - TOP 260 °F
 - BOTTOM 240 °F
- RANGE 5
 - ENABLE NO
 - COLOR RED
 - TOP 5 °F
 - BOTTOM 0 °F

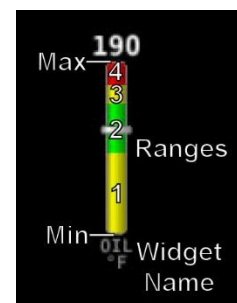

**Figure 71:
Anatomy of a
Widget, Oil
Temperature**



Note that oil temperature is configured with a latching alarm in this example. If oil temperature ever reaches a range configured as red, an alarm will trigger, and a message will show up in the message box on the Main Menu.

12.7.10 EMS Sensor Calibration

Fuel level sensors and position potentiometers must be calibrated. Your SkyView display utilizes onscreen wizards that help you do this. Go to the EMS Calibration Menu to access these wizards (SETUP MENU > HARDWARE CALIBRATION > EMS CALIBRATION).

12.8 EMS Screen Layout Editor



All sensor mapping, settings, and widget graphical properties are automatically shared between displays. Installers do not need to transfer files between displays.

Use this wizard to configure the style and layout of the engine and environmental sensor gauges and calculated parameters (e.g., % power) on the 100%, 50%, 20%, and ENGINE BOTTOM BAND Engine Pages.



SkyView HDX can display 100%, 50%, and ENGINE BOTTOM BAND pages.

Note that sensors must be defined, mapped, and configured to show up on an Engine Page (reference Section 12.6 EMS Configuration Files for instructions on how to do this).

Dynon Avionics provides EMS configuration files for approved single and twin-engine airplanes to simplify the configuration effort of your EMS system. These files are generic, but will generate the FAA approved EMS widget styles, colors, and organizational layout of the Bottom Band, 50% and 100% display pages. These files will also map the sensors to EMS pins.

To use this tool, enter the wizard (SETUP MENU > EMS SETUP > SCREEN LAYOUT EDITOR), then choose the page size to edit. Once in the Screen Layout Editor, follow this procedure:

1. *Add a sensor or info widget to the screen.* Press either SENSOR or INFO to show their respective menus and scroll through available sensors or info parameters, highlight one (1), and then press ACCEPT or move either knob to the right to add it to the screen.
2. *Change the style of the widget.* Press STYLE or turn the knob until the widget's style is acceptable.
3. *Change the size of the widget.* Press SIZE until the widget's size is acceptable.
4. *Change the location of the widget on the screen.*
 - a. In SkyView HDX, use the Left knob for movement of the widget to Left (Counterclockwise) and Right (Clockwise). Use the Right knob for movement of the widget Up (Counterclockwise), and Down (Clockwise).
5. *Repeat* the above steps for all sensors that you want displayed on the Engine Page.
6. Save the page by pressing SAVE.

Press REMOVE to remove the chosen widget from the screen. Press CANCEL to return to the EMS Setup Menu without saving any changes.

12.8.1 Example Widget Configuration

This example configures an oil temperature widget using the instructions mentioned above. This is the same oil temperature sensor that was configured earlier (see Example Oil Temperature Sensor Setup).

Open the Screen Layout Editor for the 100% page (SETUP MENU > EMS SETUP > SCREEN LAYOUT EDITOR > 100% PAGE...). Now press SENSOR, scroll to the OIL TEMPERATURE sensor, and press ACCEPT. The following widget shows up on the middle on the screen:



Figure 72: Oil Temperature Widget

The white box around the widget denotes that that widget is the one (1) that is currently being configured.

You can scroll through the available styles of the widget by pressing STYLE or by turning either knob. The following widgets illustrate different styles for oil temperature:



Figure 73: Example Oil Temperature Widget Styles

You can also adjust the size of the widget by pressing SIZE.

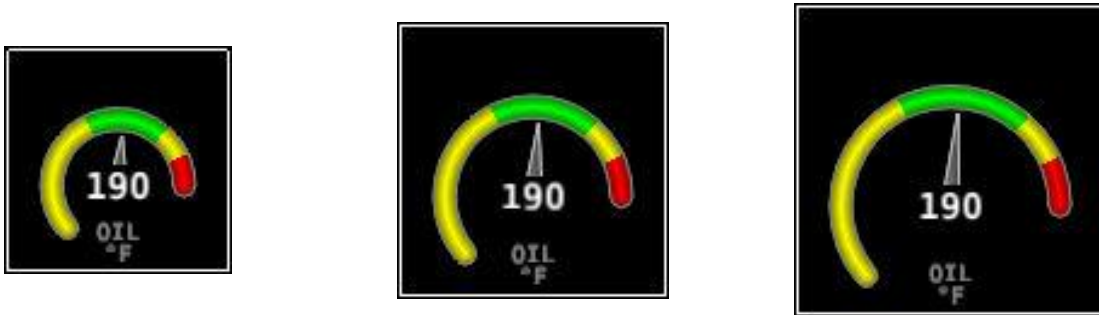

Figure 74: Example Oil Temperature Widget Sizes

Now, locate the widget on the screen by moving the knobs left, right, up, and down. Once you have decided on a location for this widget, you can add and configure more widgets (press SENSOR to add another widget and follow the procedure on the preceding page) and then save the page layout by pressing SAVE.

12.8.2 Specific Widget and Info Item Data Requirements

In order for the % Power and LOP/ROP status info items to calculate values, the following data must be present / conditions must be met:

- Barometric altitude (from an SV-ADAHRS-200) must be present.
- EMS SETUP > ENGINE INFORMATION > ENGINE TYPE must be set to Lycoming/Continental. Percent power calculations are not available for other engine types currently.
- EMS SETUP > ENGINE INFORMATION > HORSEPOWER must be set.
- OAT sensor installed / working.
- Fuel flow sensor must be installed and configured.
- MAP sensor must be installed and configured.

12.8.3 CHT and EGT Widgets

Most of the engine widgets present information from a single sensor. However, CHT and EGT can be displayed as a combined widget or as separate widgets. The combined widget is selectable in the SCREEN LAYOUT EDITOR's SENSOR list. As a combined widget, the CHT function is depicted as a symbol and the EGT function is depicted as a bar.

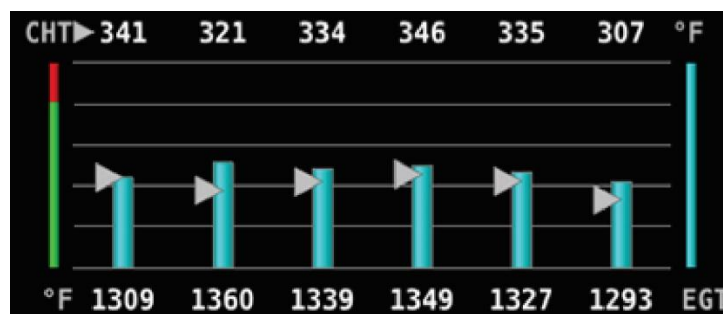

Figure 75 – Example of Combined CHT/EGT Widget (Vertical Style)

12.8.4 Twin-engine Widgets

The SCREEN LAYOUT EDITOR allows installers to place combined widgets on the Engine page for the following functions:

- Oil Pressure (OIL PRES)
- Oil Temperature (OIL TEMP)
- Fuel Pressure (FUEL PRES)
- Main Fuel Flow (MAIN FLOW)
- Amperage Load (LOAD AMPS)
- Manifold Air Pressure (MAP PRES)
- Turbine Inlet Temperature (TIT TEMP)
- RPMs (RPM RPM)

See Figure 76 for an example of a combined widget.



Figure 76 – Example of Combined Oil Temperature Widget Styles

Combined widgets are useful for laying-out Engine pages with 50% and smaller page layouts. A combined widget is selected from the SCREEN LAYOUT EDITOR's SENSOR list and are labeled Function (1 & 2). On the widget, the L (left) pointer is linked to the EMS module installed for the left engine, which is configured as ENGINE #1 EMS in SETUP MENU > EMS SETUP > DUAL EMS SETUP. The R (right) pointer is linked to the right engine EMS module (ENGINE #2 EMS). Combined widgets come in two style variations, and like the individual widgets, they come in three size variations.

If one SkyView display is being used as a dedicated Engine page with a 100% page layout, installer may consider using individual widgets to display the functions listed above. Individual widgets are selected from the SCREEN LAYOUT EDITOR's SENSOR list and are labeled Function (1) and Function (2). The Function (1) widget is linked to the EMS module installed for the left engine, which is configured as ENGINE #1 EMS in SETUP MENU > EMS SETUP > DUAL EMS SETUP. The Function (2) widget is linked to the right engine EMS module (ENGINE #2 EMS).

12.8.5 Synchroscope

The Synchroscope is used to help synchronize engine RPMs in twin-engine aircraft. Its widget is selectable in the SCREEN LAYOUT EDITOR's INFO list. The best location for the Synchroscope is near the RPM widget(s).

When the Synchroscope is rotating clockwise, the right engine is turning faster than the left. When the Synchroscope is rotating counterclockwise, the left engine is turning faster than the right.

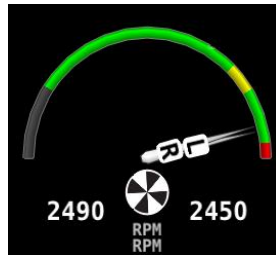

Figure 77 – Example of a Synchroscope and a Combined RPM Widget

12.8.6 Example Engine Page Layouts

This section provides some useful examples of how the SCREEN LAYOUT EDITOR can arrange widgets for different page layouts and EMS configurations.



Dynon Avionics offers preconfigured Engine page layouts that support popular engine monitoring installations. Check our website at dynoncertified.com/download.

12.8.6.1 Engine Bottom Band

The Engine Bottom Band allows the display of EMS functions along with the PFD page and/or Map page on one SkyView HDX display. This is useful when the airplane is equipped with only one display.

Depending upon how the display screen is setup, the layouts below (i.e., dials on the left side; bar graphs on the right side) may be swapped (i.e., dials on the right side; bar graphs on the left side). The side with the vital engine indicators is considered the “primary” side. The "non-primary" side may be temporarily overwritten by the display of some pages and menus, or permanently overwritten when the 50% Engine page is displayed. Therefore, it is important to lay-out the Engine Bottom Band to always display the most vital engine indicators in the primary side.



Figure 78 – Engine Bottom Band Layout for Single-engine Monitoring

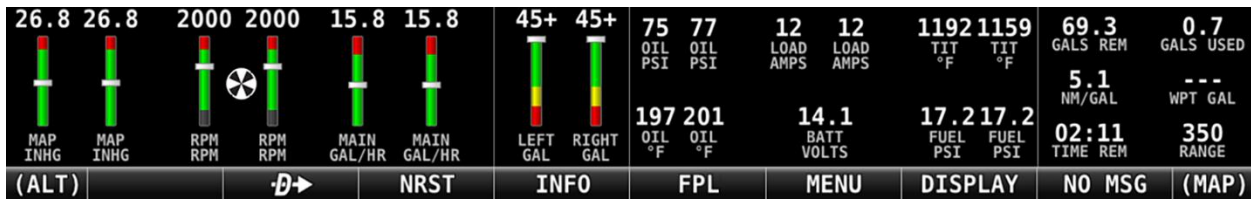

Figure 79 – Engine Bottom Band Layout for Twin-engine Monitoring



Figure 80 – Engine Bottom Band with PFD and MAP

12.8.6.2 Engine 50% Page

The 50% Engine page is a versatile layout, allowing the display of EMS functions along with the PFD page or Map page. It provides enough screen space to display all EMS functions but is often used to display selected EMS functions. In SkyView HDX, it can also be used in combination with the Engine Bottom Band to display additional engine information, like bar graphs, timers, and counters.

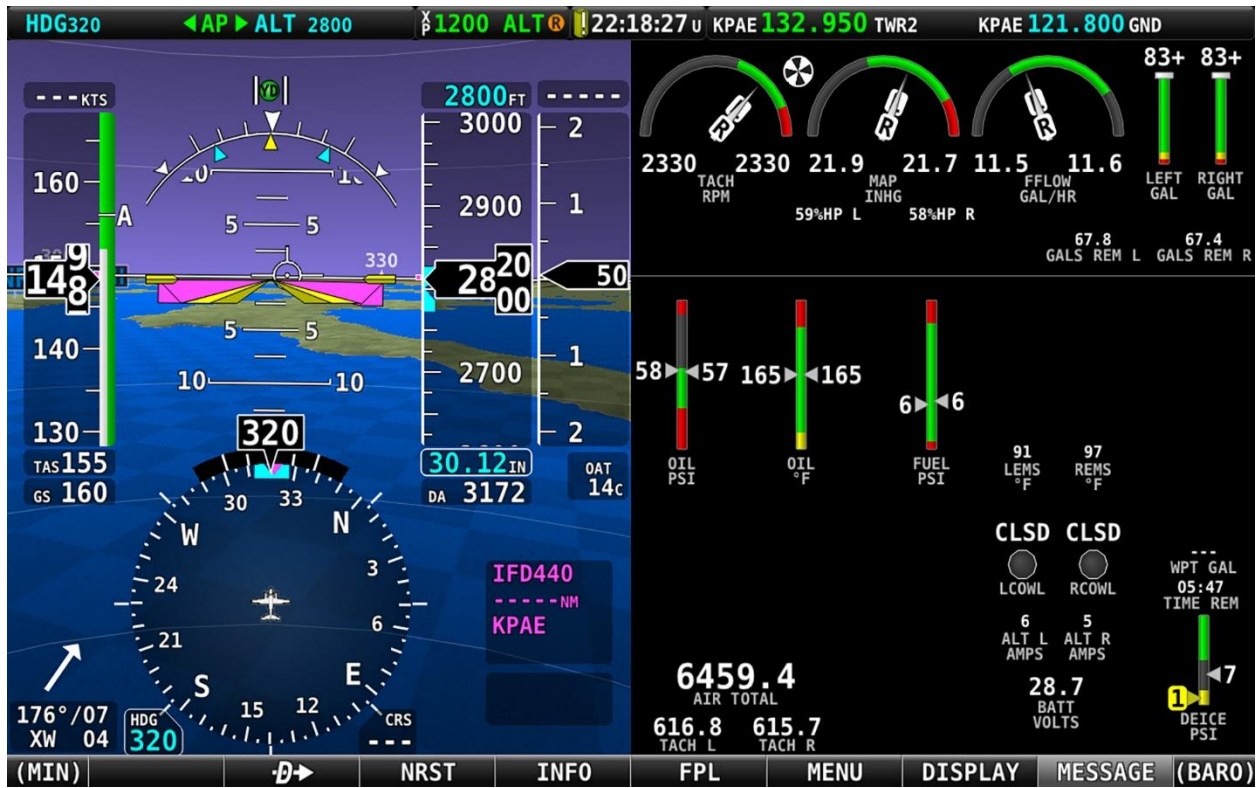

Figure 81 – 50% Page Layout with PFD.



Figure 82 – 50% Page Layout with Engine Bottom Band Overwriting 50% Page.

12.8.6.3 Engine 100% Page

The 100% Engine page layout is useful when one SkyView display is dedicated to solely displaying EMS information, or when operating the engine on the ground for maintenance reasons.

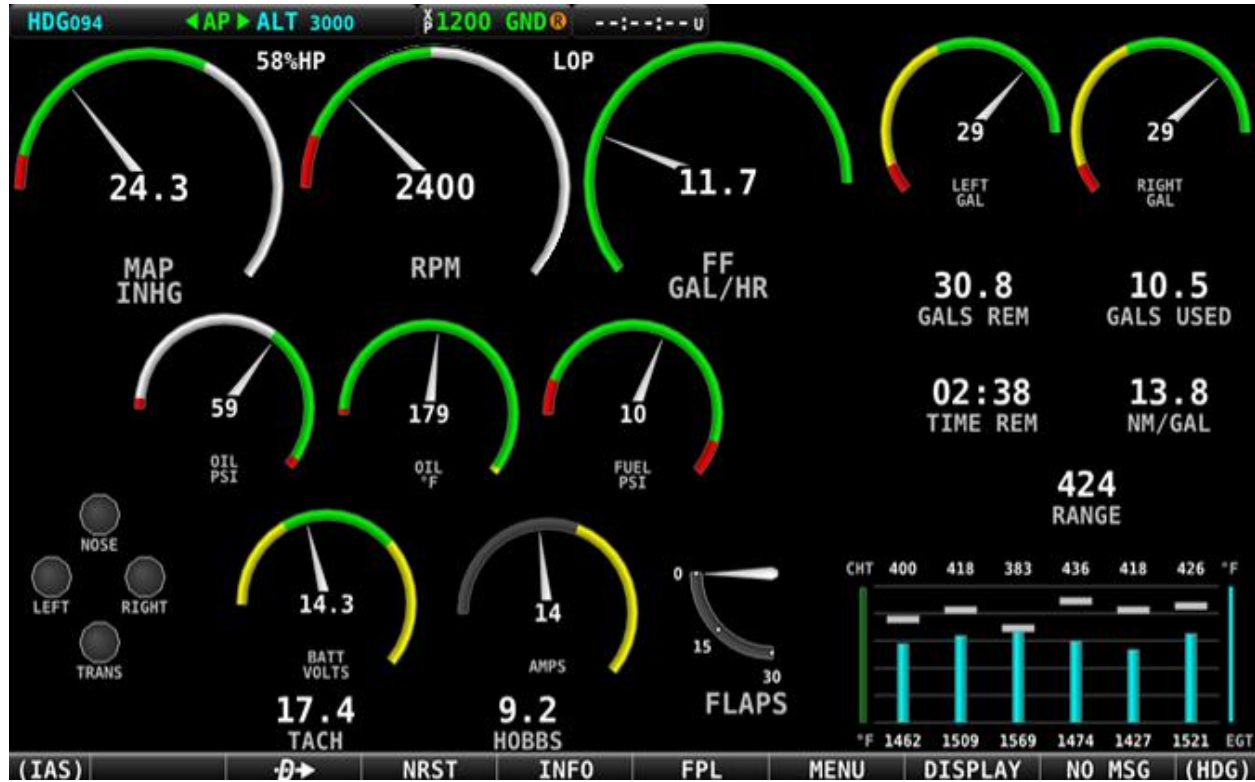

Figure 83 – 100% Page Layout for Single-engine Monitoring

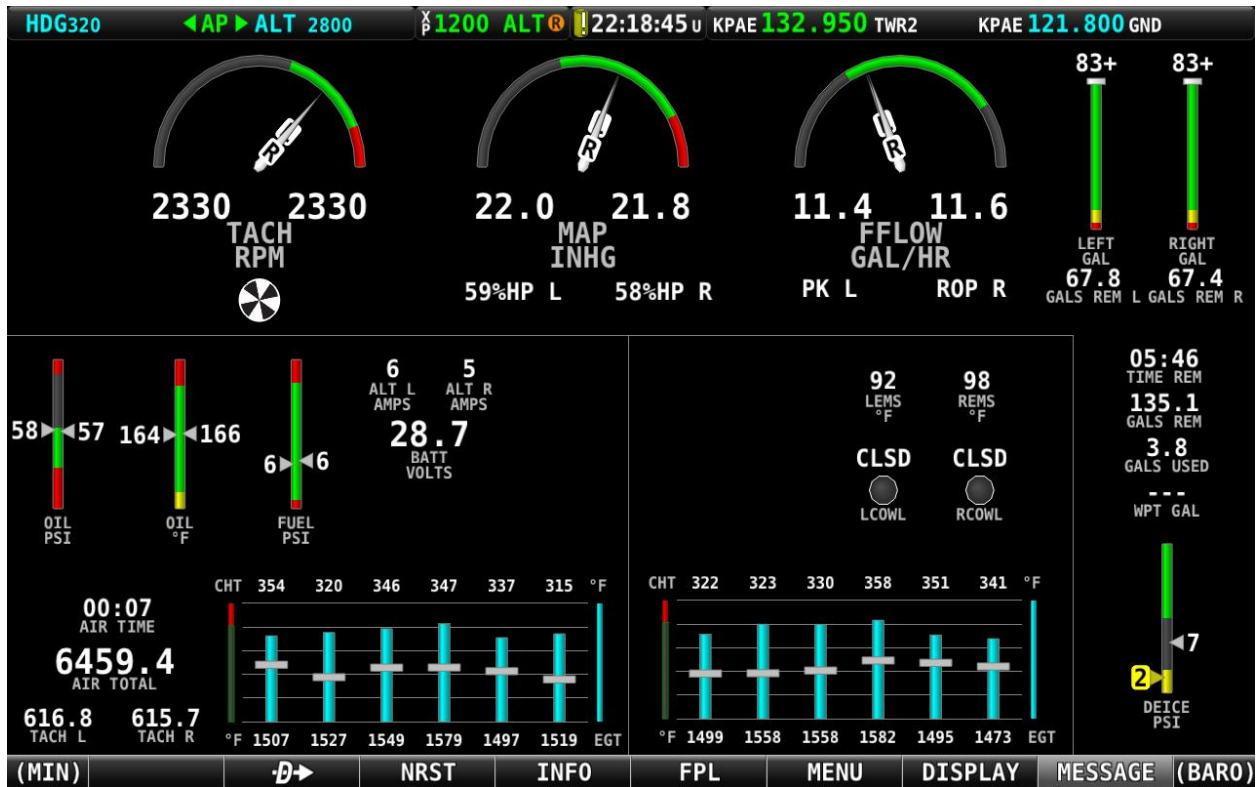

Figure 84 – 100% Page Layout with Combined Indicators for Twin-engine Monitoring



Figure 85 – 100% Page Layout with Individual Indicators for Twin-engine Monitoring

13 SV-GPS-2020 GPS Antenna/Receiver

This section explains the installation and configuration of the Dynon Avionics SV-GPS-2020 GPS Antenna/Receiver Module (High Integrity GPS).



Figure 86: SV-GPS-2020

After reading this section, you should be able to determine how to prepare the installation location, mount the unit, connect the unit to a SkyView display(s), and configure it in the SkyView display. Information specific to the SV-GPS-2020 references the individual unit. Information that is applicable to either unit is referenced by "SV-GPS-2020."

The SV-GPS-2020 is self-contained GPS receivers intended for use with the Dynon Avionics SkyView system. The SV-GPS-2020 provides "high integrity" GPS data to the SkyView system that is required by the FAA 2020 ADS-B Out mandate. Unlike similar-looking GPS units, the electronics of the GPS receiver are contained within the unit – there is no separate "electronics module" requiring a coaxial cable connection. The four (4) 22 AWG wires provide power and ground, data to, and data from the unit. The SV-GPS-2020 is powered by the SkyView display(s) and since if the SkyView display is equipped with the SV-BAT-320 Backup Battery, the SV-GPS-2020 can continue to provide GPS data in the event of a failure of the plane's electrical system.



If you are a US pilot and equipping your aircraft for the FAA 2020 ADS-B Out mandate, and plan to equip your aircraft with a secondary GPS (see below), the secondary GPS. There is no restriction on equipping a SkyView system with a second SV-GPS-2020.

Table 33: SV-GPS-2020 ADS-B Summary

Unit	Meets FAA 2020 ADS-B Out mandate? (14 CFR § 91.227)	Data Rate	SkyView Display Refresh Rate	Receives WAAS (where available)?	Intended Use For SkyView
SV-GPS-2020	Yes	115,200 baud	4 Hz	Yes	Primary GPS Receiver

13.1 WAAS Data Reception

Like most modern GPS receivers, the SV-GPS-2020 can receive satellite-based Wide Area Augmentation System (WAAS) correction data (when available) to improve positional accuracy. Many pilots confuse a GPS unit that receives WAAS data with a GPS Navigator unit that is certified for flight in Instrument Flight Rules (IFR) conditions. *To be clear, the SV-GPS-2020, connected to a SkyView system, does receive WAAS data (when available), but having a SV-GPS-2020 (but not an IFR or "certified" GPS) does not mean that your aircraft is properly equipped for legal flight under IFR.*



Only the SV-GPS-2020 or equivalent "high integrity" GPS unit meets the (GPS portion of the) requirements of the FAA 2020 ADS-B Out mandate. If you are equipping your plane for use in the US, to be compliant with the FAA 2020 ADS-B Out mandate, you must install the SV-GPS-2020.



Valid GPS data is required for time, compass calibration, moving map functionality, ADS-B IN, and ADS-B OUT, data logging, and other internal functions of the SkyView system. The SV-GPS-2020 provides positional updates much faster (i.e., 4 Hz) than typical GPS units, which provides a superior display for SynVis and map position updates.

13.2 Mechanical Installation



Do not paint an SV-GPS-2020. Doing so will negatively impact device performance.



Like all GPS devices, for most reliable performance, the SV-GPS-2020 requires a clear, unobstructed "view" of the sky. The -GPS-2020 is designed to be mounted on the upper fuselage of the aircraft for an unobstructed (360° view) of the sky during maneuvers.

Observe the following guidelines when choosing a location for an SV-GPS-2020:

- The optimal location for the device is a rigid surface on the upper fuselage of the aircraft.
- Mounting location should be relatively level (the base of the device is flat).
- Do not locate the receiver within 3 feet (91.44 cm) of transmitting antennas.
- The device should not be painted.
- Avoid antenna shadows (i.e., obstructions that block the antenna's view of the sky).
- All four (4) of the device's wires should all be connected to each SkyView system display for redundancy.

The following diagram shows the mounting dimensions of the SV-GPS-2020. Note that it utilizes a common bolt pattern found in much of general aviation.

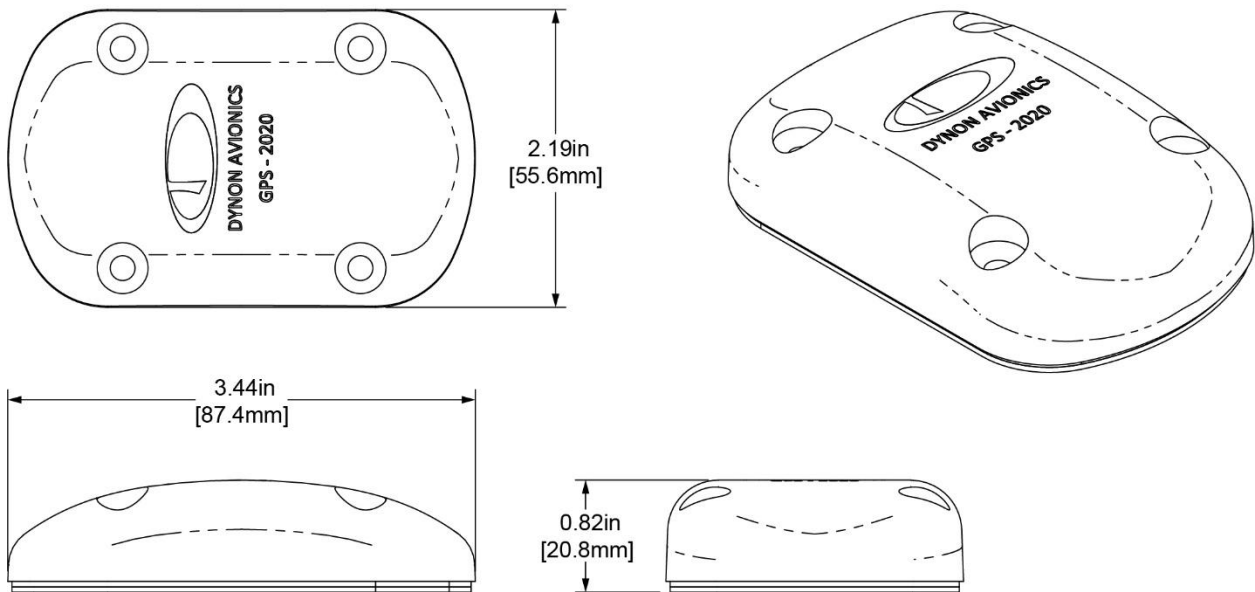
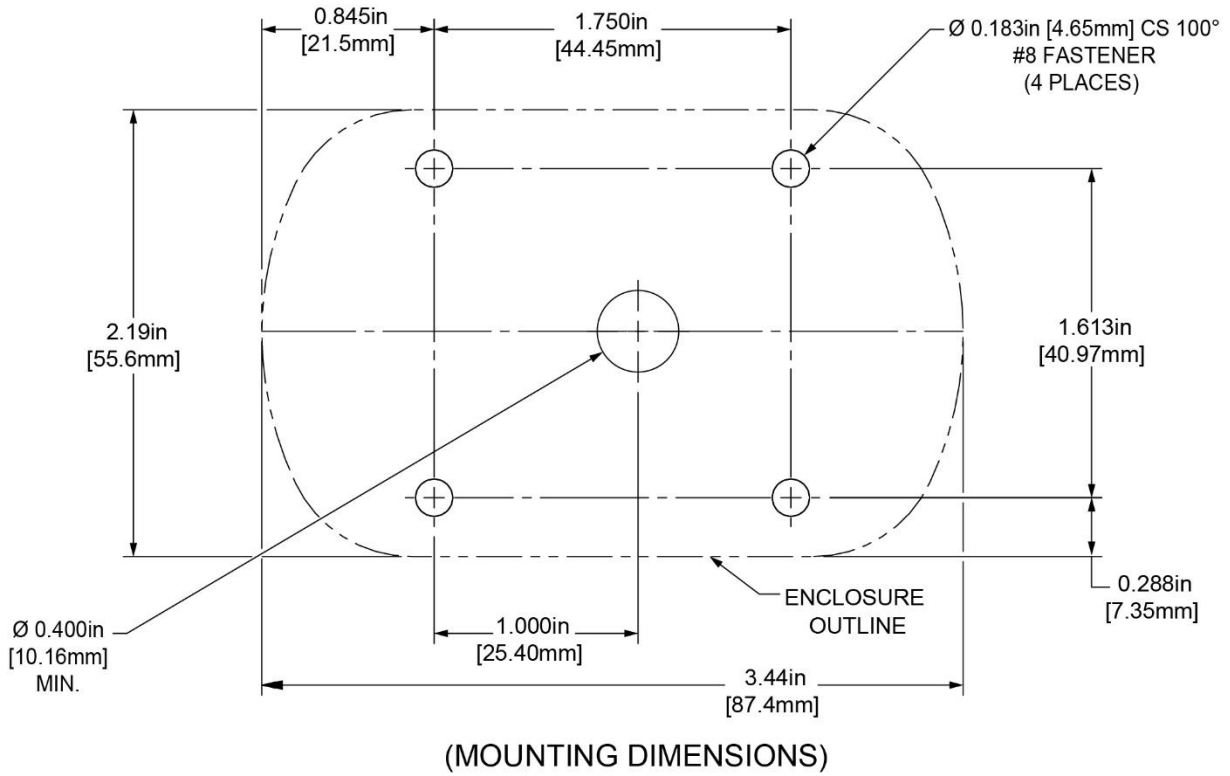

Figure 87: SV-GPS-2020 Mounting Dimensions

Mounting hardware is not included. The SV-GPS-2020 is designed to install with #8 fasteners with 100-degree countersunk heads. The use of nut plates is recommended for convenience, but other hardware can be used if space allows. Specific hardware selection is determined by the installer.

We recommend the use of weather sealant around the fastener heads to keep moisture from entering the aircraft through the mounting holes. The module itself is sealed and includes a rubber gasket that seals the inner wire hole. It also allows the module to be mounted on *slightly* curved surfaces. For extra protection, you may use weather sealant around the outside of the SV-GPS-2020 where it meets the skin of the aircraft.

13.3 Electrical Installation



For its primary source of GPS data, SkyView uses the GPS data from the device set to SERIAL IN FUNCTION: POS 1.



If your installation has two (2) or more displays, all four (4) wires of the SV--GPS-2020 must be connected to *all displays*.

The SV-GPS-2020 includes 18 feet (5.49 meters) of twisted wire for a serial connection to the SkyView display via the display. This wire may be trimmed or lengthened as needed to suit the installation – the length of these wires is not critical.

The color of the SV-GPS-2020 wires matches the colors of the wires of the SV-HARNESS-D37 that are intended for the GPS serial connection. The following table contains information regarding the wires.

Table 34: SV-GPS-2020 Serial Connection Details

Function	SkyView Display Harness SV-GPS-2020 Wire Color	SkyView Display D37 Pin
SV-GPS-2020 TX	Gray with Violet stripe	11
SkyView display Serial Port 5 RX		
SV-GPS-2020 RX	Gray with Orange stripe	12
SkyView display Serial Port 5 TX		
SV-GPS-2020 Ground	Black	24
SV-GPS-2020 Power	Orange	29

As mentioned previously, if there are two (2) or more displays in your SkyView system, all four (4) of the SV-GPS-2020's wires must be connected to all displays in parallel. This wiring scheme is illustrated in the figure below.

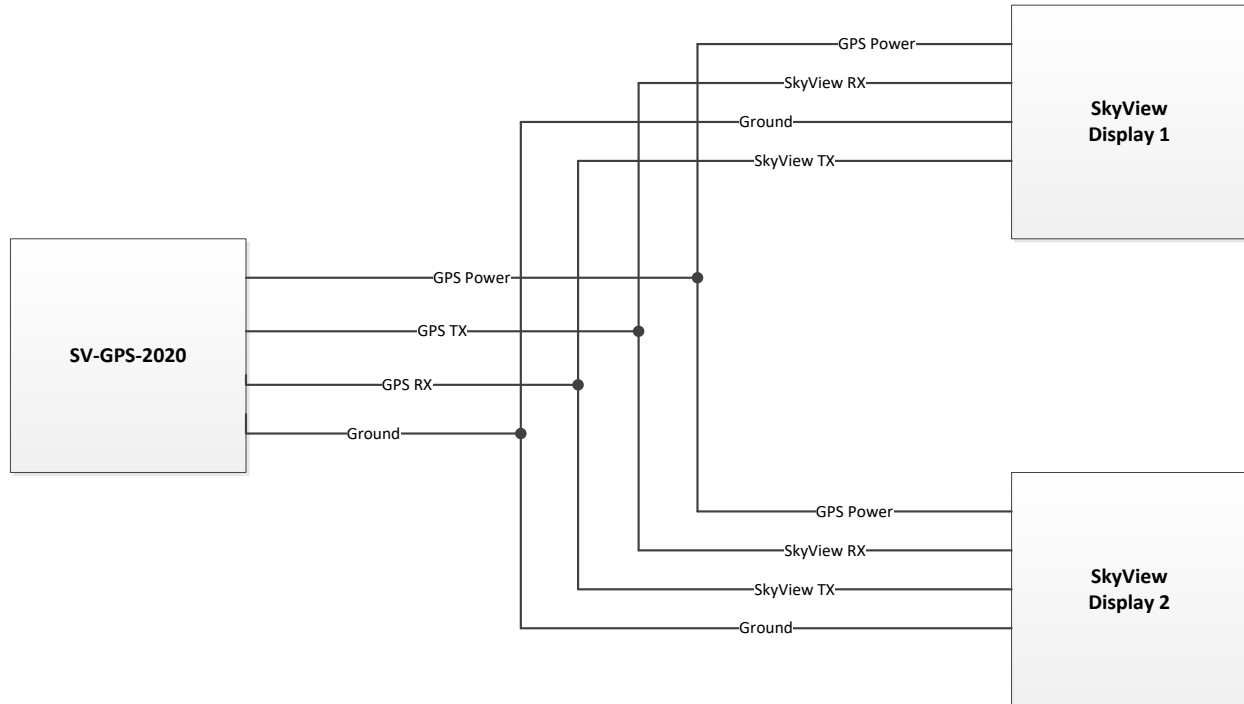

Figure 88: SV-GPS-2020 Connected to Multiple SkyView Displays

13.4 Serial Port 5 Configuration (SV-GPS-2020 only)

Go to the Serial Port Setup Menu (SETUP MENU > SYSTEM SETUP > SERIAL PORT SETUP > SERIAL PORT 5 SETUP) and then configure serial port 5 as follows:

SERIAL IN DEVICE: DYNON SV-GPS-2020
SERIAL IN FUNCTION: POS 1
NAVIGATION SOURCE DISPLAY NAME:(NOT SET)
SERIAL IN/OUT BAUD RATE: 115,200
SERIAL OUT DEVICE: DYNON SV-GPS-2020
(Highlighted settings are changed automatically from SERIAL IN DEVICE.)

13.5 Testing / Troubleshooting SV-GPS-2020 Installation



The SV-GPS-2020 are connected to the SkyView system via "serial port", and thus will not appear on the list of SkyView Network Devices during a SkyView Network configuration.

13.5.1 Basic Serial Port Functionality

Go to Serial Port Setup for the serial port you chose to use for the SV-GPS-2020 (typically Serial Port 5):

SETUP MENU > SYSTEM SETUP > SERIAL PORT SETUP > SERIAL PORT 5 SETUP



Figure 89: Serial Port 5 Setup for SV-GPS-2020

On this screen, verify the following:

- SERIAL IN DEVICE matches the device connected – either SV-GPS-2020; if the incorrect device is selected, no GPS data will be received.
- Verify that SERIAL IN FUNCTION is set to POS 1 for the primary (or only) GPS receiver, or POS 2 for the secondary GPS receiver.
- Verify that RX COUNTER and GOOD SENTENCES are incrementing.
- SENTENCE ERRORS and GROUP ERRORS should not be (significantly) incrementing.

If POS 1 is shown in Red, another GPS device has already been set as POS 1 and that "conflict" must be resolved – only one (1) GPS device can be set as POS 1, only one (1) GPS device can be set as POS 2, etc.

If RX COUNTER and GOOD SENTENCES are not incrementing, check the SV-GPS-2020 wiring, specifically that the Gray/Violet and Gray/Orange wires were connected correctly between the unit and the SkyView display. If you have more than one (1) SkyView display, the SV-GPS-2020 must be connected to *all* displays.

13.5.2 GPS Receive Performance

To verify that the SV-GPS-2020 can receive GPS signals acceptably, move the plane to an open area with a relatively unobstructed view of the sky. Moving the plane just out of a hangar, or between two (2) hangars, where a significant portion of the sky is obscured from the view of the GPS may result in poor performance of the SV-GPS-2020.

Go to GPS FIX STATUS to verify that the SV-GPS-2020 is receiving GPS signals:
 SETUP MENU > LOCAL DISPLAY SETUP > GPS FIX STATUS.

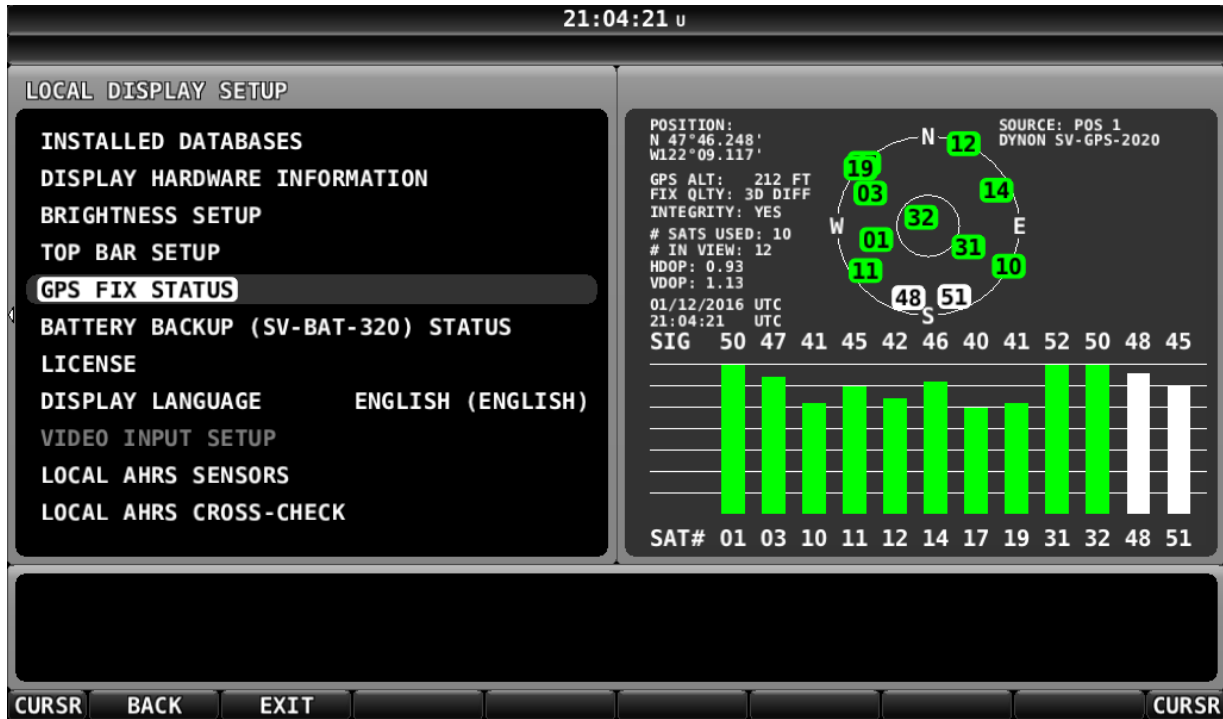

Figure 90: GPS FIX STATUS – Very Good, 3D DIFF

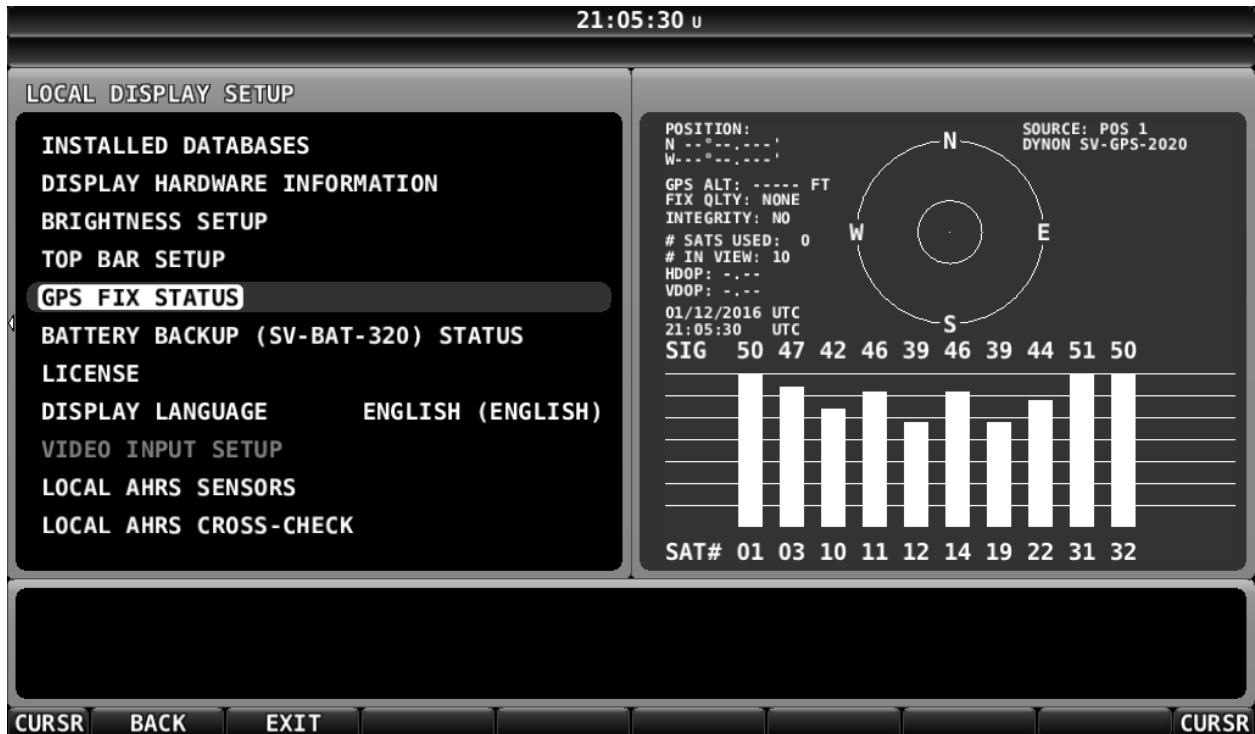

Figure 91: No GPS Fix



When the SV-GPS-2020 is powered up for the first time or is powered up after several weeks or months of not being used, the SV-GPS-2020 may require several minutes to acquire GPS signals.

The number of satellites in "view" of the SV-GPS-2020 will vary depending on the time of day, location, etc. Generally, a minimum of six (6) satellites should be shown.

On the GPS FIX STATUS screen, verify the values shown in the table below.

Table 35: Verification of SV-GPS-2020 Adequate Satellite Reception

Parameter	Minimum Value
Satellites / Bars shown:	At least 6 satellites displayed in Green
POSITION:	Valid Lat/Long shown
GPS ALT:	Valid altitude shown
Time and Date:	Valid time, date shown
FIX QLTY:	3D (good)
	3D DIFF (very good)
INTEGRITY:	YES (SV-GPS-2020)

See Table 36: GPS FIX STATUS Satellite Color Explanation (below) for an explanation of the colors.

Table 36: GPS FIX STATUS Satellite Color Explanation

Bar Color	Details
Green	Received signal strength is <i>above</i> the desired threshold, this satellite <i>is</i> used in the position solution.
Yellow	Received signal strength is <i>below</i> the desired threshold, this satellite <i>is</i> used in the position solution.
White	This satellite is in view but is not used in the position solution.



Note that GPS FIX STATUS only displays information for the GPS that is set to POS 1. If you have a second GPS installed, temporarily set that unit to POS 1 and temporarily set the primary GPS to POS 2.



If, after waiting several minutes, any of the Minimum Values shown in Table 35: Verification of SV-GPS-2020 Adequate Satellite Reception *are not shown* (such as illustrated in Figure above) it may be necessary to install the SV-GPS-2020 in a different location on the aircraft.

13.6 Additional Configuration Required for Compliance with FAA 2020 ADS-B Out Mandate



The section (above) deals with installation and configuration of the SV-GPS-2020 *only*. However, installing the SV-GPS-2020 is only part of what is required to be compliant with the FAA 2020 ADS-B Out mandate. Specifically, next steps include:

- Update your SkyView system to Software v14.0 (or later).
- Change the SV-XPNDR-261's source of GPS data to the SV-GPS-2020.

For the details on the transponder changes, and explanation of overall compliance with the FAA 2020 ADS-B Out mandate, see the SV-XPNDR-261 Transponder section.

14 SV-XPNDR-261 Transponder

The SV-XPNDR-261 transponder is a Class 1, Technical Standard Order (TSO), remote-mounted, Mode-S transponder. It emits/receives TIS Traffic (U.S. only) and is compliant with FAA 2020 ADS-B Out mandate (14 CFR § / FAR 91.227). For US aircraft, the FAA 2020 ADS-B Out mandate requires a Class 1 transponder for flight in Class B or Class C airspaces.



Figure 92: SV-XPNDR-261

The SV-XPNDR-261 transponder responds to both legacy Mode A and Mode C interrogations, as well as Mode S interrogations, from both ground radar and airborne collision avoidance systems. In all cases, the interrogations are received by the transponder on 1030 MHz, and replies are transmitted on 1090 MHz.

The SV-XPNDR-261 is DO-181D compliant Mode S level 2 els datalink transponders, with support for ADS-B Extended Squitter, which also meets the relevant environmental requirements of DO-160F/ED-14F. The SV-XPNDR-261 has a nominal power output of 250 watts and meets the power output requirements for Class 1. The ADS-B function meets DO-260B class B0 for the SV-XPNDR-262 and class B1S for the SV-XPNDR-261. The SV-XPNDR-261 is certified to ETSO 2C112b and ETSO C166a, and to FAA TSO C112c and C166b. See Appendix B: *Specifications* for more information.

The SV-XPNDR-261 is controlled using SkyView's on-screen menu system. This allows the SV-XPNDR-261 to be mounted separately from the instrument panel and thus requires no panel space. SkyView also provides pressure altitude directly to the SV-XPNDR-261, eliminating the need for a separate altitude encoder.

The SV-XPNDR-261 is "Software-based" – and has internal software that is occasionally updated. Any Software updates for the SV-XPNDR-261 are included within SkyView system software. See SV-XPNDR-261 Software Updates later in this section for details on SV-XPNDR-261 Software updates.

The SV-XPNDR-261 operates at either 14-volt nominal or 28-volt nominal DC power supply; no configuration changes are required.

14.1 Mechanical Installation

The SV-XPNDR-261 is designed to be mounted in any convenient location in the cockpit, the cabin, or an avionics bay.

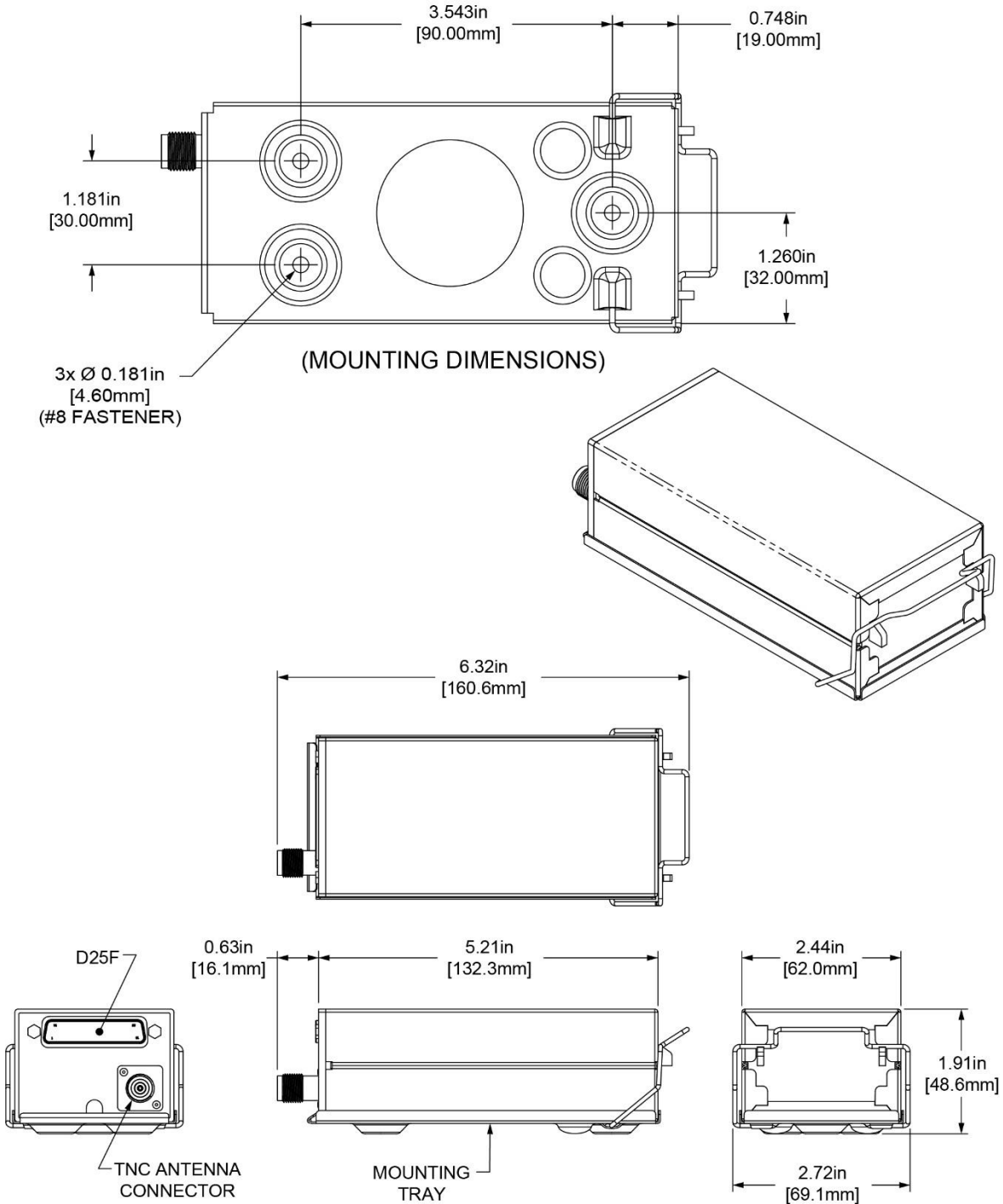

Figure 93: SV-XPNDR-261 Dimensions with Mounting Tray

The following installation procedure should be followed, remembering to allow adequate space for installation of cables and connectors:

- The SV-XPNDR-261 should be in an area that is accessible, should the SV-XPNDR-261 require service.
- Select a position in the aircraft that is not too close to any high external heat source. (The SV-XPNDR-261 is not a significant heat source itself and does not need to be kept away from other devices for this reason).
- It is acceptable to locate the SV-XPNDR-261 remotely from the panel, such as in the aft fuselage, to minimize the length of coaxial cable between the SV-XPNDR-261 and the transponder antenna.
- Orientation of the SV-XPNDR-261 is not critical – it can be mounted horizontally, or vertically.
- Secure the mounting tray to the aircraft via the three (3) mounting holes in the tray. The tray should be mounted to a flat surface - it is important that the tray is supported at the dimples as well as the three (3) mounting points.
- Put the SV-XPNDR-261 transponder into the secured mounting tray by hooking the connector end under the lip on the tray.
- Lock the SV-XPNDR-261 into the mounting tray by clipping the retaining wire over the lugs on the opposite end.
- Avoid sharp bends and placing the cables too near to the aircraft control cables.

14.1.1 Cooling Requirements

The SV-XPNDR-261 meets all applicable TSO requirements without forced air-cooling; therefore, no additional cooling is required for the SV-XPNDR-261.

14.1.2 Additional Items Required

Additional items you will require, but which are not in the SV-XPNDR-261 package, include:

- Antenna and fixing hardware. The SV-XPNDR-261 is compatible with any transponder antenna conforming to TSO-C74.
- Cables and TNC Female connector (or TNC Female to BNC Male adapter). You need to supply and fabricate all required cables (or cable and connector is included with your transponder antenna). Guidance on cable types is given below.
- Mounting hardware: To secure the SV-XPNDR-261 tray to the airframe you will need at least three (3) flat head screws and three (3) self-locking nuts. If the aircraft does not have existing mounting provisions you may need to fabricate additional brackets to support the SV-XPNDR-261 tray.

14.2 Electrical Installation

14.2.1 SV-XPNDR-261 Harness Construction

For connecting the SV-XPNDR-261, Dynon Avionics offers the optional SV-HARNESS-XPNDR harness (pictured at right). This harness is not included with the SV-XPNDR-261. It comes with 15 feet (4.572 m) of wire, and the connector is pre-wired. If required, the harness can be shortened, or lengthened (length is not critical).



Table 37: SV-HARNESS-XPNDR Pinout (below) reflects the wiring colors of the SV-HARNESS-XPNDR.

The SV-XPNDR-261 has a single D25F connector which provides the data and power inputs to the SV-XPNDR-261. A single TNC female coaxial connector attaches to the antenna.

Because the SV-XPNDR-261 can be mounted in a variety of locations, the harness length requirements will vary between various aircraft.

The SV-XPNDR-261 package includes a 25-pin connector and pins if you wish to fabricate your own harness. Refer to the sections below for detailed wiring information. Note that your connector kit may contain a 1.21K resistor. This resistor is only used if you intend to connect a certified GPS receiver for ADS-B Out functionality.

Additional harness construction and wiring information can be found in Section 31 *Appendix C: Wiring and Electrical Connections*.

Table 37: SV-HARNESS-XPNDR Pinout

Pin	Function	SV-HARNESS-XPNDR Color	Notes
1	Loopback 1	White	Connect to Pin 2
2	Loopback 1	White	Connect to Pin 1
3	GPS Serial Input	White	Certified GPS Only for ADS-B Out (see explanation below)
4	No Connection	No wire installed	-
5	SV-XPNDR-261 Serial RX	Orange	Data Input from SkyView Display(s): Serial 1 – Pin 4 (Brown / Orange), or Serial 2 – Pin 6 (Yellow / Orange), or Serial 3 – Pin 8 (Green / Orange), or Serial 4 – Pin 10 (Blue / Orange)
6	No Connection	No wire installed	-
7	SV-XPNDR-261 Serial TX	Violet	Data Output to SkyView Display(s): Serial 1 – Pin 3 (Brown / Violet), or Serial 2 – Pin 5 (Yellow / Violet), or Serial 3 – Pin 7 (Green / Violet), or Serial 4 – Pin 9 (Blue / Violet)
8	No Connection	No wire installed	-
9	No Connection	No wire installed	-
10	No Connection	No wire installed	-
11	No Connection	No wire installed	-
12	Loopback 2	White	Connect to Pin 13
13	Loopback 2	White	Connect to Pin 12
14	Ground	Black	Connect to Aircraft Ground
15	11-33V DC	Red	Connect to Aircraft Power
16	No Connection	No wire installed	-
17	External Standby In	No wire installed	Optional: Not Commonly Connected
18	Mutual Suppression	No wire installed	Optional: Not Commonly Connected
19	Squat Switch In	Yellow	Optional: Not Commonly Connected
20	Ident Switch In	Green	Optional: Not Commonly Connected
21	No Connection	No wire installed	-
22	No Connection	No wire installed	-
23	No Connection	No wire installed	-
24	No Connection	No wire installed	-
25	No Connection	No wire installed	-

The figure below depicts how the SV-XPNDR-261 connects with other SkyView and aircraft components. Note that many of the connections shown are optional and are not used in most installations.

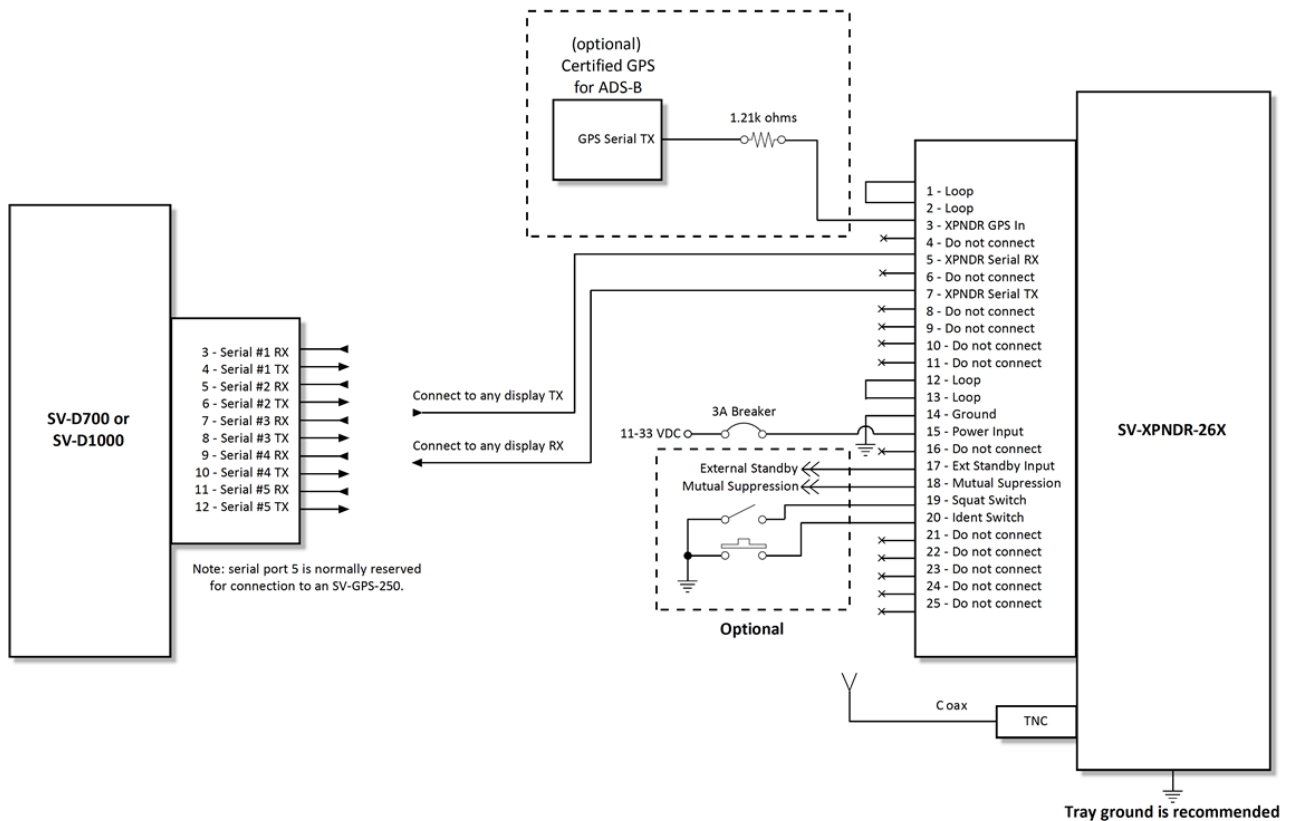

Figure 94: SV-XPNDR-261 Wiring Diagram

The table below shows the connections for each of SkyView’s nominally available serial ports. Serial Port 5 is usually used for connection to the SV-GPS-2020 GPS receiver. Only ONE (1) of the following serial ports will be used to connect the SV-XPNDR-261.

Table 38: Example SkyView/SV-XPNDR-261 Serial Port Connections

Serial Port	SkyView D37	SV-XPNDR-261 D25
1	Pin 3 (RX) Brown/Violet	Pin 7 (TX)
	Pin 4 (TX) Brown/Orange	Pin 5 (RX)
2	Pin 5 (RX) Yellow/Violet	Pin 7 (TX)
	Pin 6 (TX) Yellow/Orange	Pin 5 (RX)
3	Pin 7 (RX) Green/Violet	Pin 7 (TX)
	Pin 8 (TX) Green/Orange	Pin 5 (RX)
4	Pin 9 (RX) Blue/Violet	Pin 7 (TX)
	Pin 10 (TX) Blue/Orange	Pin 5 (RX)

The figure below shows a typical set of connections for the SV-XPNDR-261 D25 connector, as viewed from the wiring side of the D25 connector:

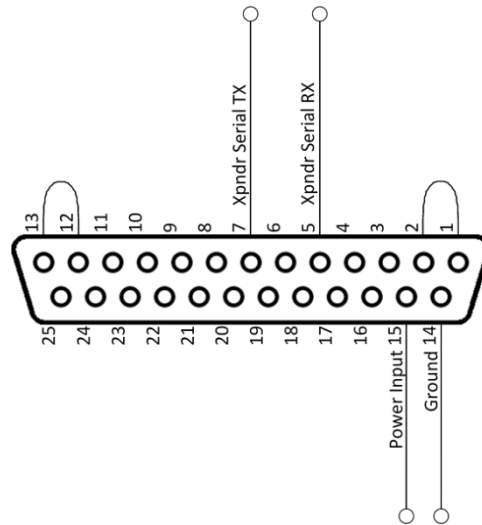

Figure 95: Typical SV-XPNDR-261 Connections (Rear Pin Insertion View)

The figure below shows all possible connections, as viewed from the wiring side of the D25 connector:

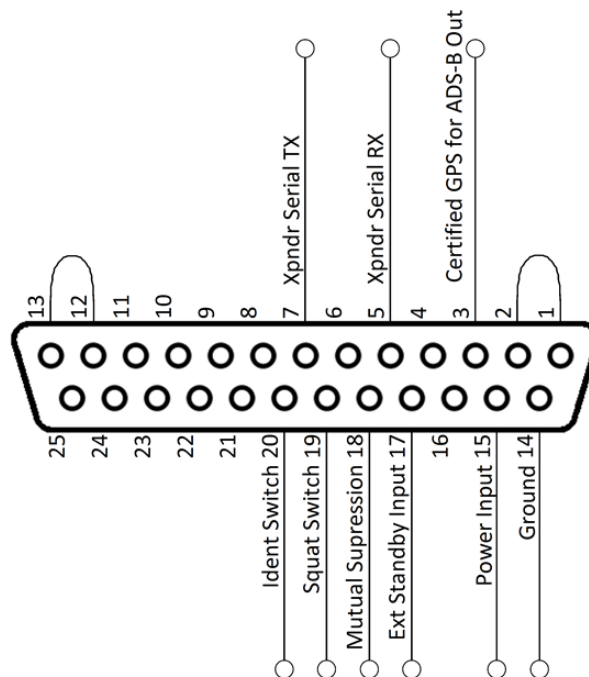

Figure 96 – All Possible SV-XPNDR-261 Connections (Rear Pin Insertion View)



Note that Pin 1 and Pin 2 must be connected to each other as depicted above as part of the wiring harness (they are not connected inside the SV-XPNDR-261).

Note that Pin 12 and Pin 13 must be connected to each other as depicted above as part of the wiring harness (they are not connected inside the SV-XPNDR-261).

14.2.2 Power / Ground Input

The power supply can be 11-33 Volts DC; no voltage adjustment is required. 20 AWG wire is sufficient for wire runs up to 50' for this application. Note that the SV-XPNDR-261 must be connected to aircraft power – none of SkyView's voltage outputs can provide enough power to power the SV-XPNDR-261.

It is always good practice to use more than one (1) ground path in an installation. With only one (1) wire there may be only a single grounding path for the SV-XPNDR-261, controller and antenna. This can allow static electricity to build up and damage your SkyView display(s). Ensuring that the mounting tray is grounded provides an adequate alternative ground path to protect against such events. This is particularly important when the SV-XPNDR-261 is mounted on a non-conducting surface, such as a composite structure, where the mounting tray is often not grounded. Therefore, make sure that the mounting tray is grounded in addition to having the ground wire connected as depicted above.



Note: The SV-XPNDR-261 power input is ***not protected against reversed power connections***. If the power and ground inputs to the SV-XPNDR-261 are reversed, and power is applied to the Ground input, and Ground is applied to the Power input, the SV-XPNDR-261 will be destroyed and this repair will not be covered under warranty. *Check wiring before applying power!*

14.2.3 Pin 1/2 and 12/13 Loopbacks

Pins 1 and 2 must be connected together (as shown in Figure 94, Figure 95, and Figure 96 above). Pins 12 and 13 must be connected together (as shown in Figure 94, Figure 95, and Figure 96 above).

14.2.4 Serial RX (Pin 5) and Serial TX (Pin 7)

All communication between the SV-XPNDR-261 module and SkyView is accomplished via a single bidirectional serial connection. To accomplish this:

- Choose an unused serial port on each display to connect the SV-XPNDR-261. Note that both the TX and RX sides of the serial port are needed, and both the RX and TX lines must be connected to all displays in parallel. It is required that the same numerical serial port on each display be used.
- Connect the SV-XPNDR-261 TX wire (pin 7) to the SkyView serial RX of your choosing. If you have multiple displays, the SV-XPNDR-261's TX wire must be connected to a serial RX wire on each display.
- Connect the SV-XPNDR-261 RX wire (pin 5) to the SkyView serial TX of your choosing. If you have multiple displays, the SV-XPNDR-261's RX wire must be connected to a serial TX wire on each display.

- Record the SkyView serial port that you have chosen on each display as you will need to configure it later for use with the SV-XPNDR-261.

14.2.5 Mutual Suppression (Pin 18) (optional)

Mutual Suppression allows two (2) or more transmitters on adjacent frequencies to inhibit the other transmitters when one (1) is active to limit the interference effects. It is commonly used between transponders and DME systems, and between transponders and collision avoidance systems. Most installations will not make use of this feature, since most SkyView-equipped aircraft have only one (1) transponder and often do not have DME equipment or other active traffic system that interrogate other aircraft.

The Mutual Suppression pin, Pin 18, is an ARINC compatible suppression bus interface, which acts as both an input and an output. The SV-XPNDR-261 will assert this signal when it is transmitting and can be suppressed by other equipment that asserts the signal. The SV-XPNDR-261 will drive approximately twenty-four (24) Volts on the output (independently of supply voltage) and will treat the input as active whenever the bus has greater than ten (10) Volts.

If you are using the Mutual Suppression feature, simply connect all the Mutual Suppression wires from devices that use them together.

14.2.6 Ident Switch Input (Pin 20) (optional)

SkyView has an IDENT button in its TRANSPONDER menu that is normally used to ident when requested by ATC. However, the ident switch input allows the IDENT function to be selected using a remote switch. The input is active low and will be asserted when the voltage to ground is pulled below approximately four (4) Volts. Therefore, a momentary switch to ground should be installed on this output if a remote ident switch is desired.

14.2.7 Squat Switch Input (Pin 19) (optional)

In a SkyView system, a Squat Switch is not required because SkyView can automatically detect whether ALT or GND mode is appropriate, and switch modes as necessary. Thus, the Squat Switch Input should be left unconnected. See the AUTO ALT/GND setting in the SV-XPNDR-261 Settings section of later in this section.

The Squat switch input allows the SV-XPNDR-261 to automatically switch between Airborne and Ground modes and affects both the Mode S reply behavior and the ADS-B reporting behavior. The input will be asserted when the voltage to ground is pulled below approximately 4 Volts. The logical sense of the input can be programmed to be either active low or active high in the SkyView Setup Menu.

If connected, this must be a mechanical switch that accurately reflects the aircraft's on-ground status. Mode-S certification requirements state that this cannot be a simple airspeed switch.

14.2.8 External Standby Input (Pin 17) (optional)

This input, when connected to Ground, places the SV-XPNDR-261 in Standby mode. It should be used to switch between transponders in an installation with two (2) transponders. The input is active low and will be asserted when the voltage to ground is pulled below approximately four (4) Volts.

14.2.9 Direct Serial GPS Position Input (Pin 3)

This input is typically used if the aircraft is already equipped with a certified GPS unit (typically for qualification for IFR flight). This input is connected to a serial port output of the certified GPS. See SV-XPNDR-261 Settings, GPS Data later in this section for information on how to configure SkyView to use this capability.

If you connect a certified GPS to this input, you must install a 1.21k resistor (included with the SV-XPNDR-261) between the certified GPS and the SV-XPNDR-261 as shown in Figure 94: SV-XPNDR-261 Wiring Diagram.

14.2.10 Antenna Cable

The SV-XPNDR-261 is designed to meet Class 1 requirements with the same 2 dB allowance. Excessive loss will degrade both transmitter output power and receiver sensitivity.

Allowing 0.25 dB loss for the connector at each end of the antenna cable assembly leaves an allowance of 1.5 dB maximum loss for the cable itself.

An acceptable cable:

- Has less than 1.5 dB loss for the run length needed.
- Has a characteristic impedance of 50Ω (50 Ohms).
- Has double braid screens or has a foil and braid screen.

Once the cable run length is known, a cable type with low enough loss per metre that meets the above requirements can be chosen. Longer runs require lower loss cable. Consider moving the SV-XPNDR-261 closer to the antenna to minimize the losses in the antenna cable – subject to the limits identified above, the SV-XPNDR-261 can be at any distance from the SkyView display(s) without affecting performance in any way.

Note: Low loss cable typically uses foamed or cellular dielectrics and foil screens. These make such cables especially prone to damage from too-tight bends or from momentary kinking during installation. Once kinked, these cables do not return to full performance when straightened.

Table 39 below is a guide to the maximum usable lengths of some common coaxial cable types. Actual cable loss varies between manufacturers, there are many variants, and the table is therefore based on typical data. Use it as a guide only and refer to the manufacturer’s data sheet for your specific chosen cable for accurate values.

Table 39: Maximum Usable Lengths of Some Common Coaxial Cable Types

Max Length in Meters	Max Length in Feet	Insertion Loss dB/meter at 1090MHz	MIL-C-17 Cables	Electronic Cable Specialists Type	SSB Electronic
2.54	8' 4"	0.59	M17/128 (RG400)		
3.16	10' 4"	0.47		3C142B	

3.81	12' 6"	0.39	M17/112 (RG304)		
4.50	14' 9"	0.33			Aircell 5
5.25	17' 3"	0.29	M17/127 (RG393)	311601	
6.42	21' 1"	0.23		311501	
6.81	22' 4"	0.22			Aircell 7
8.22	26' 11"	0.18		311201	
12.59	41' 3"	0.12		310801	

Contact Electronic Cable Specialists on +1 414 421 5300 or at <http://www.ecsdirect.com> for their data sheets. Contact SSB-Electronic GmbH on +49-2371-95900 or at <http://www.ssb.de> for their data sheets.

When routing the cable, ensure that you:

- Route the cable away from sources of heat.
- Route the cable away from potential interference sources such as ignition wiring, 400Hz generators, fluorescent lighting and electric motors.
- Allow a minimum separation of one (1) foot / 12 inches (3.5 cm) from an ADF antenna cable.
- Keep the cable run as short as possible.
- Avoid routing the cable around tight bends.
- Avoid kinking the cable even temporarily during installation.
- Secure the cable so that it cannot interfere with other systems.

14.2.11 Antenna TNC Female Connector

This section describes the technique for attaching the antenna cable to a TNC Male connector. A TNC Male connector is not supplied with the SV-XPNDR-261. The SV-XPNDR-261 has a TNC Female connector. Therefore, you will need to source a TNC Male connector that is compatible with the antenna cable type that meets your aircraft's needs. Alternatively, especially if the transponder antenna you have purchased incorporates coaxial cable and a "BNC" connector, you can purchase a "Male TNC to Female BNC" adapter (see below).

A dual crimp style TNC connector can be completed using a wide range of commercial crimp tools (for example the Tyco 5-1814800-3). The die apertures for the inner pin and the outer shield should be approximately 0.067 inches (1.72 mm) and 0.213 inches (5.41 mm) respectively.

- Strip back the coax cable to the dimensions in the table, as shown in the diagram below. Slide 1 inch (25.4 mm) of heat shrink tubing over the cable.
- Slide the outer crimp sleeve over the cable – it must go on before securing the center contact.

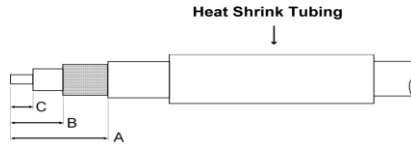

Figure 97: Transponder COAX Cable

Table 40: Coaxial Cable Strip Dimensions

Dimension	Cut size (mm)	Cut size (inches)
A	17.5	0.69
B	7.2	0.28
C	4.8	0.19

- Crimp the center contact to the cable.
- Insert the cable into the connector – the center contact should click into place in the body, the inner shield should be inside the body of the connector and the outer shield should be outside the body.
- Crimp the outer sleeve over the shield.
- Slide heat shrink tubing forward (flush to connector) and heat to shrink the tubing.

14.2.12 TNC to BNC Adapter

If you have purchased a transponder antenna that has coaxial cable and a BNC connector already installed, you can use a "Male TNC to Female BNC" adapter to adapt the SV-XPNDR-261's TNC connector to a BNC Female connector. As this adapter will be used for transmitting radio frequency energy above 1 GHz, we recommend that you purchase an adapter by a reputable manufacturer of radio frequency connectors and adapter such as Amphenol. The part pictured at right is an Amphenol P/N 242149, and is available from Digi-Key as P/N ACX1378-ND.



Figure 98: TNC to BNC Adapter (typical)

14.3 Transponder-Related SkyView Display Settings

14.3.1 Serial Port Setup

Before the TRANSPONDER SETUP menu can be accessed, the SV-XPNDR-261 needs to be set up as a serial device in the SkyView system. To accomplish this:

- SETUP MENU > SYSTEM SETUP > SERIAL PORT SETUP
- Select the serial port to which you connected (physically – the wires) the SV-XPNDR-261 – SERIAL PORT 1, SERIAL PORT 2, SERIAL PORT 3, or SERIAL PORT 4.

- Select either DYNON SV-XPNDR-261 or DYNON SV-XPNDR-262 as appropriate. Note that other fields are automatically configured and cannot be changed. Press ACCEPT.

The data transmitted between the SkyView display and the SV-XPNDR-261 nominally includes encoded altitude data from SkyView's ADAHRS. Therefore, no other altitude encoder hardware is required. However, some locales may require the use of a certified altitude encoder with the Dynon Avionics SV-XPNDR-261. SkyView supports external serial altitude encoders that use Icarus/Garmin format (connected via serial port to one (1) of the SkyView display's serial ports). When an external serial is connected, the SV-XPNDR-261 uses the external altitude encoder data source instead of SkyView's pressure altitude (from the SV-ADAHRS-200/201). However, the pressure altitude displayed by SkyView on the PFD page is ALWAYS sourced from the SV-ADAHRS-200/201.

To have SkyView use an external altitude serial encoder as the pressure altitude source for the SV-XPNDR-261:

1. Connect a SkyView display serial RX to the respective serial TX connection from the serial altitude encoder. If your SkyView system has multiple displays, this connection must be made to all SkyView displays in parallel.
2. Ensure there is a shared ground between the SkyView display and the serial altitude encoder.
3. Configure the SkyView display serial port RX: SETUP MENU > SYSTEM SETUP > SERIAL PORT SETUP > SERIAL PORT x SETUP > SERIAL IN DEVICE > ICARUS/GARMIN ALTITUDE. (The other parameters are set automatically).

14.3.2 SV-XPNDR-261 Settings



The aircraft tail number must be set in SETUP > SYSTEM SETUP > AIRCRAFT INFORMATION > TAIL NUMBER prior to configuring the transponder.

The following settings need to be configured before testing and using the SV-XPNDR-261. They are all accessed under SETUP MENU > TRANSPONDER SETUP:

- STATUS: Displays online/offline status, displays hardware, Software, and Software versions of the SV-XPNDR-261. If shown in **YELLOW**, a Software update for the SV-XPNDR-261 is available for the SkyView display – see SV-XPNDR-261 Software Updates later in this section for details on performing Software updates.
- USA PART 91.227 COMPLIANT: YES | NO Displays whether the combination of the selected GPS, the SV-XPNDR-261 model, and the GPS data being received is compliant with 14 CFR § 91.227 (YES is displayed) or not (NO is displayed).

When this field is highlighted, additional information about the status (YES | NO) is displayed, such as no data is being received from the GPS, thus NO is displayed. NO could be displayed when the GPS is not powered on or does not yet have a

full "lock" on the GPS constellation (such as when you are in a hangar). Error Messages include:

- TRANSPONDER SOFTWARE NEEDS TO BE UPDATED – The SV-XPNDR-261's Software has not been updated to v2.6 (minimum for compliance with 14 CFR § 91.227).
- NO COMPLIANT GPS PRESENT – The type of GPS selected is not compliant.
- NO GPS DATA (GPS OFFLINE OR MISCONFIGURED) – GPS data of the format selected is not being received by the SV-XPNDR-261.
- GPS PROTOCOL MISCONFIGURED, CHANGE TO ADS-B – PROTOCOL – The Garmin GPS is transmitting the older ADS-B format rather than the (now) required ADS-B PLUS (+) format.

See also Determining SkyView System's with FAA 2020 ADS-B Out Mandate Compliance later in this section.

- **TRANSPONDER WARNINGS:** If a message other than NONE appears for TRANSPONDER WARNINGS, see Transponder Warnings (Transponder Self Diagnostics) later in this section for detailed explanation of the various transponder warnings.
- **GPS DATA:** Displays status of the GPS input to the SV-XPNDR-261: GPS DATA (OK) – GPS data is being received by the SV-XPNDR-261 or GPS DATA (OFFLINE) – GPS data is not being received by the SV-XPNDR-261.

Also select the source of GPS input to the SV-XPNDR-261 (explained below):

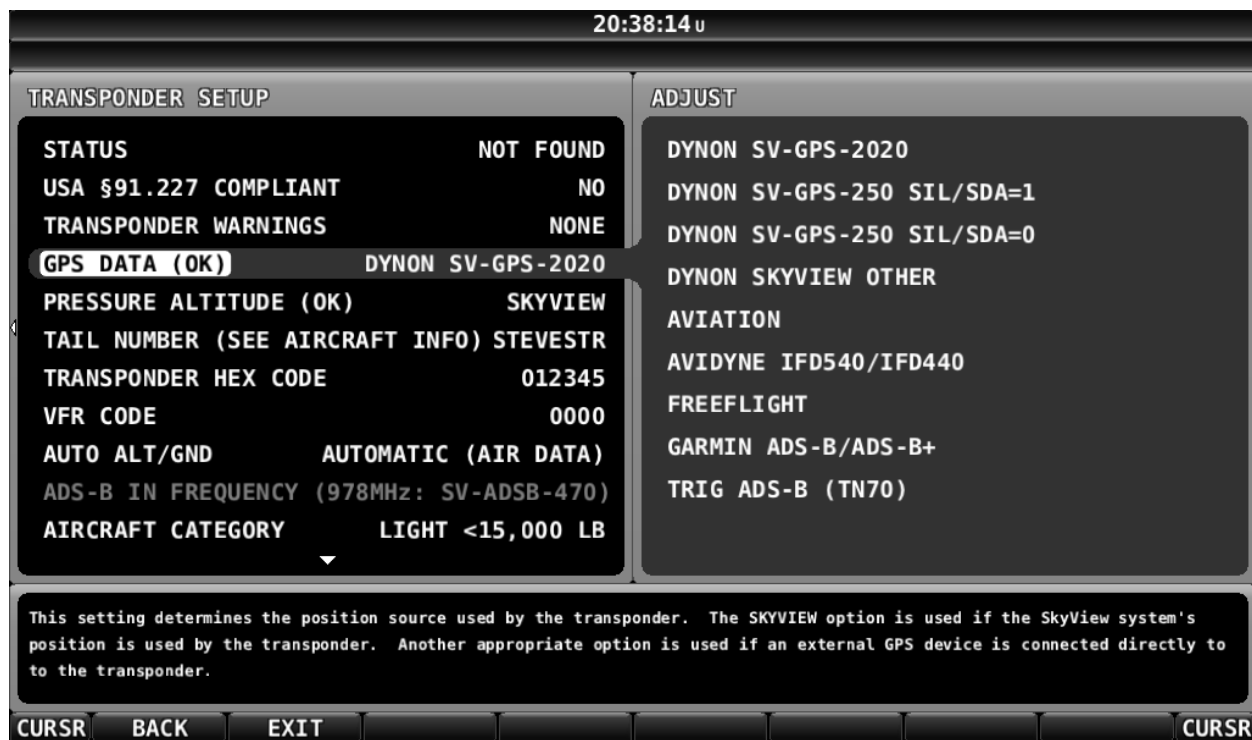

Figure 99: SV-XPNDR-261 GPS DATA Setup

- NONE
 - Select this option if you are operating outside the United State and need to disable ADS-B OUT transmissions without disabling GPS-based functions.
- DYNON SV-GPS-2020:
 - Select this option if you have an SV-GPS-2020 installed.
 - The following ADS-B performance parameters will be transmitted:
 - SDA: 2.
 - SIL: 3.
 - NACp: Dynamic, as reported by GPS.
 - NIC: Dynamic, as reported by GPS.
 - NACv: 1 (10m/s accuracy).
- DYNON SKYVIEW OTHER:
 - Select this option if you have another type of GPS connected to your SkyView system and you wish that GPS data to be transmitted as part of ADS-B out transmissions.

- The following ADS-B performance parameters will be transmitted:
 - SDA: 0 (Unknown integrity).
 - SIL: 0.
 - NACp: 8, 9 or 10. Dynamic, as reported by GPS.
 - NIC: 8 (Containment radius <0.1 NM).
 - NACv: 1 (10m/s accuracy).



Use of any of the DIRECT GPS-to-transponder position reporting methods below require that the GPS that is connected to the SV-XPNDR-261 be TSO'd when used in the US. Additionally, *only specific models are supported via these connections*. Other countries may have different regulatory requirements for GPS position indicators that are connected directly to the SV-XPNDR-261's direct serial input.

- AVIDYNE IFD540/IFD440: Must be connected directly to SV-XPNDR-261 pin 3, transmitting at 9600 baud. This device is only supported in SV-XPNDR-261 version 2.06 or later; see SV-XPNDR-261 Software Updates below for more information about updating the SV-XPNDR-261 Software. Using this setting causes the SV-XPNDR-261 to transmit the following ADS-B performance parameters:
 - SDA: 2 (Level C integrity).
 - SIL: 3.
 - NACp: Sent from GPS to transponder. Refer to GPS documentation.
 - NIC: Sent from GPS to transponder. Refer to GPS documentation.
 - NACv: 1 (10m/s accuracy).
- FREEFLIGHT: FreeFlight 1201 or 1204 GPS, connected directly to SV-XPNDR-261 pin 3, transmitting at 19200 baud. Using this setting causes the SV-XPNDR-261 to transmit the following ADS-B performance parameters:
 - SDA: 2 (Level C integrity).
 - SIL: 3.
 - NACp: Sent from GPS to transponder. Refer to GPS documentation.
 - NIC: Sent from GPS to transponder. Refer to GPS documentation.
 - NACv: 1 (10m/s accuracy).
- GARMIN ADS-B/ADS-B+: Garmin GNS 400W/500W series (WAAS) or Garmin GTN series, both with appropriate Software updates as designated by Garmin, connected directly to SV-XPNDR-261 pin 3, transmitting at 9600 baud in "ADS-B+ OUT" or "ADS-B" format. "ADS-B" format only works with SV-XPNDR-261 Software 2.02 and above. "ADS-B+" format requires SV-XPNDR-261 version 2.06 or later. With 2.06 or later Software the format in

use will be auto-detected. The original Garmin ADS-B format is not compliant for use after 2020 and may cause compliance failures in the FAA's ADS-B monitoring system but is acceptable to use until 2020. See SV-XPNDR-261 Software Updates below for more information about updating the SV-XPNDR-261 Software. Using this setting causes the SV-XPNDR-261 to transmit the following ADS-B performance parameters:

- SDA: 2 (Level C integrity) SIL: 3 NACp: Sent from GPS to transponder. Refer to GPS documentation.
NIC: Sent from GPS to transponder. Refer to GPS documentation.
NACv: 1 (10 m/s accuracy).
- TRIG ADS-B (TN70): Must be connected directly to SV-XPNDR-261 pin 3, transmitting at 19200 baud. This device is only supported in SV-XPNDR-261 version 2.06 or later. See SV-XPNDR-261 Software Updates below for more information about updating the SV-XPNDR-261 Software. Using this setting causes the SV-XPNDR-261 to transmit the following ADS-B performance parameters:
 - SDA: 2 (Level C integrity) SIL: 3 NACp: Sent from GPS to transponder. Refer to GPS documentation.
NIC: Sent from GPS to transponder. Refer to GPS documentation.
NACv: 1 (10 m/s accuracy).
- PRESSURE ALTITUDE: Displays status of pressure altitude input for the SV-XPNDR-261.
- TAIL NUMBER (SEE AIRCRAFT INFO): Displays tail number (set in SYSTEM SETUP > AIRCRAFT INFORMATION).
- TRANSPONDER HEX CODE: A Mode-S transponder's HEX code is more precisely called a 24-bit ICAO code. All aircraft that fly with a Mode S transponder must have the correct ICAO code that is assigned to the specific aircraft, configured in the aircraft's Mode-S transponder. The ICAO / HEX code uniquely identifies the aircraft and the country in which it is licensed. All ICAO / HEX codes are assigned by the aircraft licensing authority in the country in which the aircraft is registered/licensed.

The SV-XPNDR-261 setup requires the hexadecimal number (base 16) format; SkyView cannot accept the Octal (base 8) or Decimal (base 10) format.



For US registered aircraft with a conventional (pattern) N-number, when the tail number is entered, the HEX CODE will be set automatically (computed based on the aircraft N-number). If the TRANSPONDER HEX CODE cannot be computed, the TRANSPONDER HEX CODE remains set to 000000.



The HEX CODE needs to be set to the aircraft's assigned code for the SV-XPNDR-261 to function properly. The default code of 000000 is not a valid code. If the code is left at 000000, the SV-XPNDR-261 will only work in SBY mode. A caution message – XPNDR HEX CODE NOT SET will appear if an SV-XPNDR-261 is configured in SkyView, but the HEX CODE is not set to a valid number.

There is no "special" HEX CODE that can be input to the SV-XPNDR-261 that will enable it to operate as a Mode A and/or Mode C transponder only.

- For US aircraft can be found at the FAA aircraft registry at https://www.faa.gov/licenses_certificates/aircraft_certification/aircraft_registry/. The FAA aircraft register shows both the octal number and the hexadecimal value.
- The website <http://www.airframes.org> provides HEX CODEs for most countries' aircraft that can be input into SkyView. The HEX CODE is the value shown in the ICA024 result field.
- If you only have the octal number, you must convert it to hexadecimal. There is an Octal to Hexadecimal converter tool available in the Support section of <http://www.trig-avionics.com/>.
- FLIGHT ID: Allows pilots to enter an ADS-B Flight ID for aircraft. Available options include:
 - UNUSED: ADS-B Flight ID feature is disabled
 - RESET AT POWER ON: ADS-B Flight ID is enabled, and feature control appears on Transponder control page. Upon SkyView power up, Flight ID is blank (i.e., reset). If no Flight ID is entered, SkyView will report the aircraft's tail number by default.
 - SAVE AND RESTORE: ADS-B Flight ID is enabled, and feature control appears on Transponder control page. Upon SkyView power up, previously entered Flight ID is entered (i.e., restored).
- VFR CODE: When the pilot presses the VFR button, a pre-programmed code will replace the current squawk code. The pre-programmed code is set here; the choice of code will depend on the normal location of the aircraft.
 - In the USA, the VFR squawk code is 1200.
 - In most parts of Europe, the VFR squawk code should be set to 7000.
- AUTO ALT/GND: Allows the SV-XPNDR-261 to automatically switch between Airborne and Ground modes. Available options include:
 - NONE: Automatic switching disabled
 - SQUAT SWITCH LOW ON GND: Utilizes a physical squat switch connected the SV-XPNDR-261 per the above instructions. When this option is selected, the SV-XPNDR-261 will consider the aircraft to be on the ground when this switch is low (electrically grounded).

- SQUAT SWITCH LOW IN AIR: Utilizes a physical squat switch connected the SV-XPNDR-261 per the above instructions. When this option is selected, the SV-XPNDR-261 will consider the aircraft to in flight when this switch is low (electrically grounded).
- AUTOMATIC (AIR DATA): The SV-XPNDR-261 automatically determines whether the aircraft is in flight or not by using a combination of GPS and air data changes from SkyView. Note that this option only works with SV-XPNDR-261 Software 2.02 or above. See SV-XPNDR-261 Software Updates below for more information about updating the SV-XPNDR-261 Software. This is the option that most SkyView systems should use unless they are required to use a Squat Switch. If a Squat Switch is installed and connected, this option will cause the Squat Switch to be ignored.
- ADS-B IN FREQUENCY:



If an SV-ADSB-472/472 is installed and configured under SETUP MENU > SYSTEM SETUP > SERIAL PORT SETUP, this option will be unavailable: The SV-ADSB-472/472 automatically receives ADS-B In traffic and weather via the 978 MHz UAT frequency band. The SV-ADSB-472 also uses the 1090 MHz band to receive traffic.



Note that the options in the ADS-B IN FREQUENCY only have an effect with SV-XPNDR-261 Software 2.02 or above. See SV-XPNDR-261 Software Updates below for more information about updating the SV-XPNDR-261 Software.

- If an SV-ADSB-472 is not installed and configured, the following settings are accessible:
 - NONE – Set to NONE if there is no ADS-B IN equipment on board the aircraft.
 - 1090 MHz ES – Select this option if there is ADS-B IN equipment on board that receives *only* on 1090 MHz.
 - 978 MHz UAT – Select this option if there is ADS-B IN equipment on board that receives on 978 MHz (other than the Dynon Avionics SV-ADSB-472). Select this option if the ADS-B IN equipment on board is dual-band (receives on both 1090 MHz and 978 MHz).
- AIRCRAFT CATEGORY: To assist ATC tracking of aircraft, an aircraft category can be transmitted by Mode S transponders. Set as appropriate for your aircraft.
- AIRCRAFT LENGTH and AIRCRAFT WIDTH: On the ground, ADS-B transmits encoded aircraft size information which is used by ATC to identify taxiing routes and potential conflicts. Using the aircraft length and width (wingspan), in your current distance/speed units (meters or feet), the SV-XPNDR-26 will calculate the appropriate size code for transmission.

- **MAXIMUM CRUISE SPEED:** Mode S transponders can transmit their maximum airspeed characteristics to aircraft equipped with TCAS. This information is used to help identify threats and to plan avoiding action by the TCAS equipped aircraft. The airspeeds are grouped in ranges. Set as appropriate for your aircraft.
- **TIS TRAFFIC:** Enables the display of TIS traffic on the SkyView Map page when in an area served by a TIS-enabled RADAR. Note that TIS is a Mode S uplink service that is provided by some US approach RADARs. TIS coverage is limited to the coverage areas of those radars; there is no TIS provision outside the USA. If another traffic device is connected to SkyView and is set up correctly, its traffic information will trump the TIS traffic from the SV-XPNDR-261, regardless of this setting.

14.4 Equipping for FAA 2020 ADS-B Out Mandate Compliance (U.S. Only)



The FAA's ADS-B rule currently permits class A1, A1S, A2, A3, B1S, or B1 transponder-based 1090ES ADS-B transmissions for compliance once the FAA 2020 ADS-B Out rules mandate goes into effect January 1, 2020. Therefore, only the higher power class B1S SV-XPNDR-261 will be able to meet the 2020 ADS-B Out requirement. If your aircraft is equipped with an SV-XPNDR-262, it must be replaced with an SV-XPNDR-261 (or other Class 1 Mode-S transponder) to be compliant with the FAA 2020 ADS-B Out mandate.

It is important to note that in the U.S., the ADS-B Out "mandate" and the associated GPS requirements do not go into effect until January 1, 2020, and the mandate only requires compliance in specific airspaces. If you do not have an SV-GPS-2020 (or an appropriately TSO'd WAAS IFR GPS navigator - such as the Garmin GTN or GNS (WAAS only) series) installed, SkyView will send data from the SV-GPS-2020 to the SV-XPNDR-261.

The FAA 2020 ADS-B Out mandate is codified in 14 CFR § 91.225 and 14 CFR § 91.227. In general, these regulations require that as of January 1, 2020, if you operate an aircraft in, below, or above Class B or Class C airspace, or above 10,000 feet in Class E airspace, an airplane plane must be equipped with:

- A Class 1 Mode S transponder with 1090ES ADS-B Extended Squitter that meets the performance required in 14 CFR § 91.227 (or UAT; Dynon Avionics' solution uses the former).
- The GPS supplying position data to the above transponder must meet the specific performance requirements as defined in 14 CFR § 91.227.

The Dynon Avionics SV-XPNDR-261, as a TSO C166B device, meets the transponder and ADS-B transmission requirements for 14 CFR § 91.225 and 14 CFR § 91.227.

The Dynon Avionics SV-GPS-2020, as a high integrity GPS receiver, meets the specific performance requirements as defined in 14 CFR § 91.227.

Additional options for a GPS receiver that meets the specific performance requirements as defined in 14 CFR § 91.227 include (that are supported by direct input to the SV-XPNDR-261):

- Avidyne IFD440 and IFD540.
- FreeFlight 1201 and 1203.
- Garmin GNS (WAAS only).
- Garmin GTN.
- Trig Avionics TN70.

14.4.1 Installation of SV-GPS-2020 for FAA 2020 ADS-B Out Mandate Compliance

The most common GPS position source for compliance for performance requirements for GPS data for FAA 2020 ADS-B Out mandate is the SV-GPS-2020 GPS Antenna/Receiver Module (High Integrity GPS - meets FAA 2020 ADS-B Out requirements). Installation is described in SV-GPS-2020 GPS Antenna/Receiver earlier in this manual. For compliance, the SV-GPS-2020 must be installed in conjunction with an installed SV-XPNDR-261 with up-to-date Software (see SV-XPNDR-261 Software Updates later in this section), and SkyView Software v14.0 (or later).

If you have already installed and configured the serial port setup for an SV-GPS-2020, perform the following steps to complete the SV-GPS-2020 installation:

SETUP MENU > TRANSPONDER SETUP > GPS DATA (OK) and select DYNON SV-GPS-2020.

14.4.1.1 Determining SkyView System's with FAA 2020 ADS-B Out Mandate Compliance

SkyView can provide guidance as to whether your ADS-B Out installation and configuration is compliant with the FAA ADS-B Out 2020 Mandate (SkyView Software v12.2 or later is required): SETUP MENU > TRANSPONDER SETUP – Note the second line.

14.4.1.2 FAA Report for FAA ADS-B OUT 2020 Mandate Compliance

After you have updated your SkyView system with a SV-GPS-2020 (or other IFR GPS connected directly to the SV-XPNDR-261), and updated your SV-XPNDR-261's Software to SW02.08 or later, you should fly within an ADS-B coverage area(s) for at least several hours (minimum), or days (optimum), before requesting the report below. This will give the ADS-B system some reasonable amount of data with your aircraft's *new* ADS-B configuration on which to assess your compliance with the FAA 2020 ADS-B mandate.

Go to <https://www.faa.gov/nextgen/programs/adsb/>

See the first highlighted section entitled:

ADS-B Out Equipped?

Enter your N-number, ADS-B transmitter and GPS make/model numbers to find out if your equipment is working properly.

The web address is:

<https://adsbperformance.faa.gov/PAPRRequest.aspx>

Include the following:

- (your N-number).
- ADS-B transmitter: Dynon Avionics SkyView SV-XPNDR-261 transponder.
- GPS: Dynon Avionics SV-GPS-2020.

The FAA will respond with a report showing whether you comply, or not, with the FAA 2020 ADS-B mandate. If you do not comply, there will be detailed information about your aircraft's issues in complying with the FAA 2020 ADS-B Out mandate.

14.4.2 Altitude Encoder Calibration

In most transponder systems, a calibration is normally carried out every 24 months, as part of the altimeter checks on the aircraft. The maximum allowed difference between the primary altimeter and the altitude encoder is 125 feet (38 meters) in ETSO C88a and TSO C88b. The primary altimeter in SkyView and the altitude encoder are the same device (SV-ADAHRS-200). It is therefore impossible for the encoder and the primary altimeter to exceed 125 feet (38 meters) of altitude difference. They will always be exactly the same as each other, thereby meeting the TSO requirements. Therefore, no altitude encoder calibration is possible or necessary.

At times it may be useful to know the altitude that is being reported to the transponder. Since SkyView sends pressure altitude to the SV-XPNDR-261, setting BARO to 29.92 will display the pressure altitude being transmitted to the transponder in the normal SkyView altitude display on the right side of the PFD page.

However, note that there is a single point altitude adjustment, located in SETUP MENU > HARDWARE CALIBRATION > ADAHRS CALIBRATION > ALTITUDE OFFSET that adjusts SkyView's barometric altimeter. This adjustment affects both the displayed altitude and the encoded altitude that is sent to other devices.

14.5 SV-XPNDR-261 Software Updates



If your SkyView system has more than one (1) SkyView display, before you commence with the SV-XPNDR-261 Software update, it is recommended to power off all but one (1) SkyView display. Doing so will reduce the power drain on your aircraft electrical system during the SV-XPNDR-261 Software update and minimize the chances of any interruptions to the update process while it is underway.

You can power off an individual display by pushing and holding Button 1 on the display to be powered off.

To determine your SV-XPNDR-261's Software version, go to SETUP MENU > TRANSPONDER SETUP and observe the STATUS line, as illustrated in the figure below.

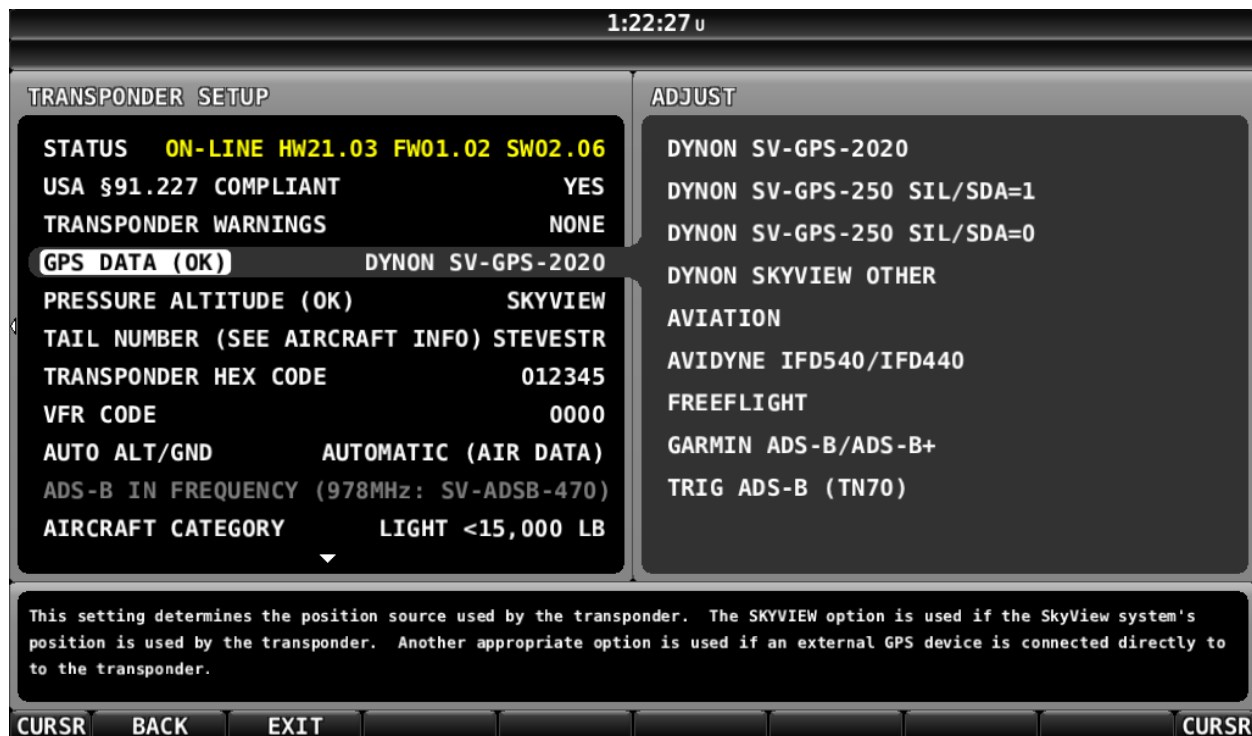

Figure 100: SV-XPDR-261 Software Update Available

If the STATUS line is shown in **YELLOW**, a Software update for the SV-XPDR-261 is available from the SkyView display.

If the STATUS line is shown in White (normal), as illustrated in the figure below, the SV-XPDR-261 Software is up-to-date with the Software update available in the current version of SkyView Software currently installed on your SkyView display.

To update your SV-XPNDR-261, select STATUS and right-click. You will see the screen shown in the figure below.

Note the reference to "LOAD WILL BE INITIATED BY MASTER SCREEN". In a SkyView system, one (1) display is elected "Master" behind the scenes, and the "Master" display will be the one (1) to actually load the new Software onto the SV-XPNDR-261, which may not be the display that you began the Software update on (if all displays remained powered on) – see the tip at the beginning of this procedure to power off all but one (1) SkyView display.

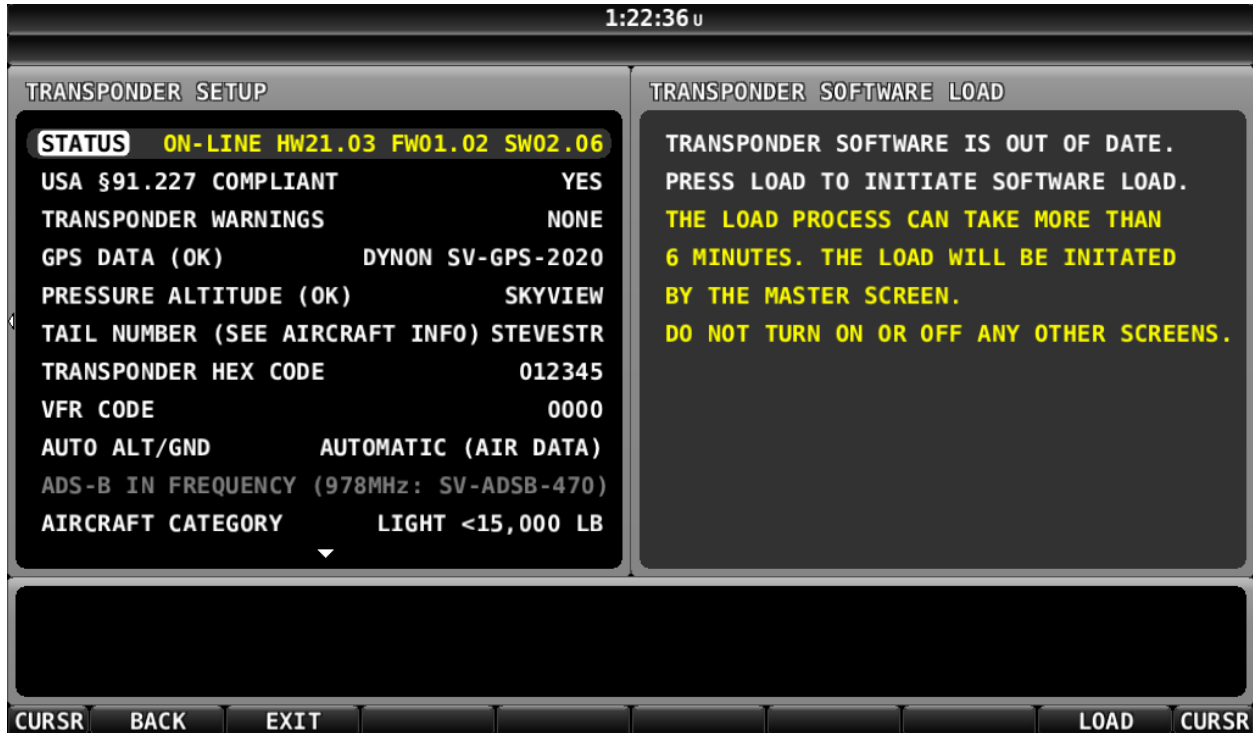

Figure 101: SV-XPNDR-261 Software Update Ready to Load

After pushing the LOAD button, the screen in the figure below appears. This is to ensure that you intended to perform a Software update to the SV-XPNDR-261. Push the YES button.



It is critical not to interrupt the Software update process, thus you should ensure that there is adequate electrical power for the SkyView display(s) and the SV-XPNDR-261 to operate uninterrupted for at least ten (10) minutes.

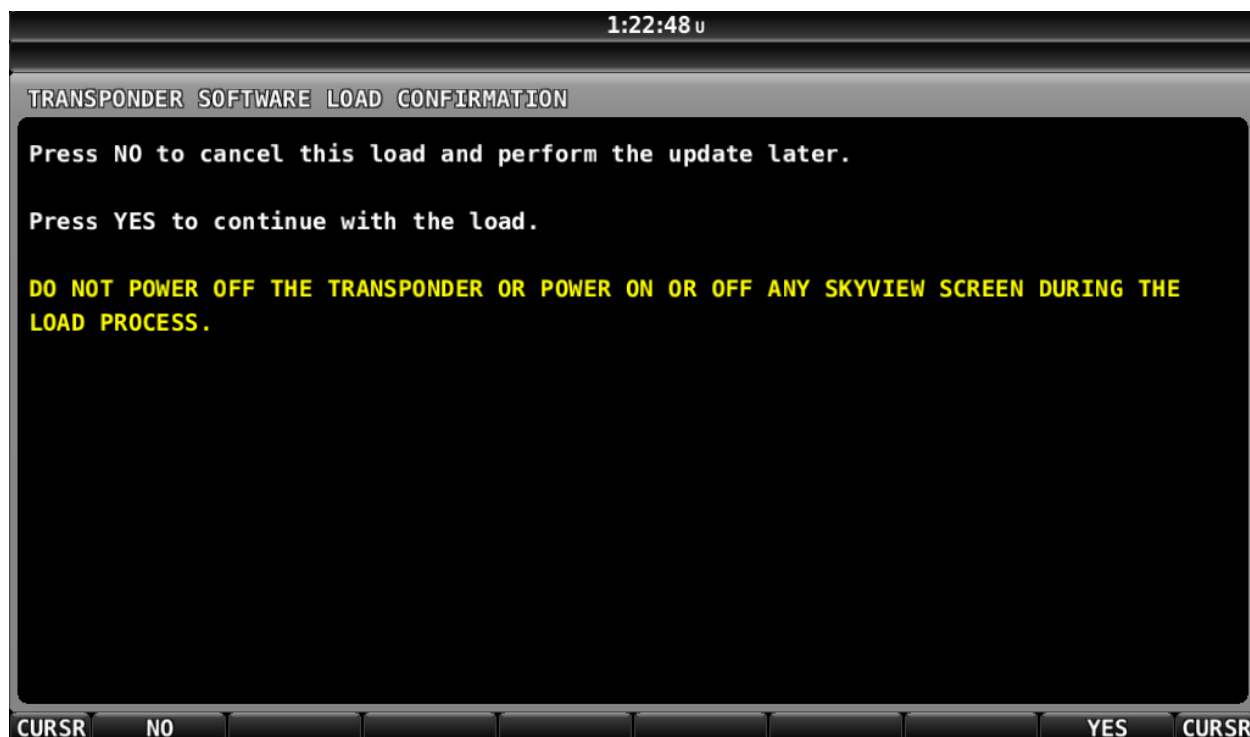

Figure 102: SV-XPNDR-261 Software Update Confirmation Screen

The figure below is the screen that appears after the Software update is complete. Once the Software update is complete, the SV-XPNDR-261 requires a power cycle to restart with the newer Software. Simply power down the SV-XPNDR-261, using the transponder switch, circuit breaker, etc. Or simply power off the MASTER or AVIONICS switch. A power-off of only a few seconds is required.

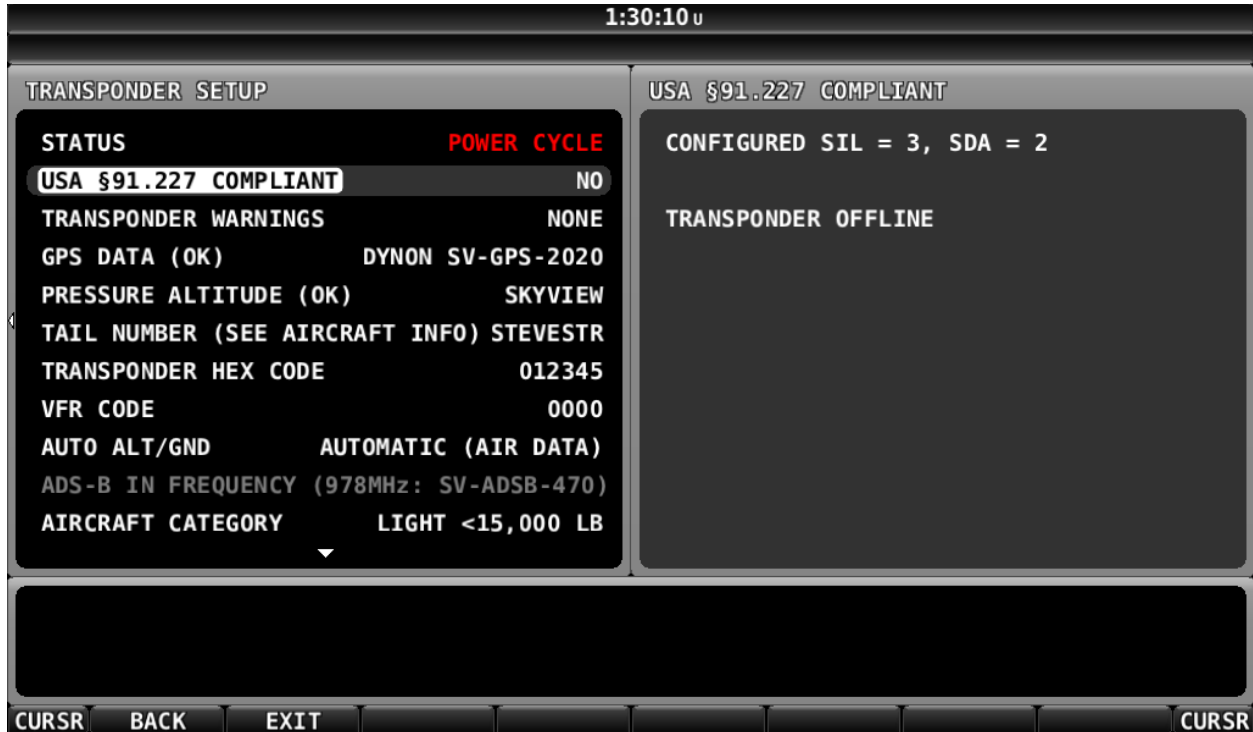

Figure 103: SV-XPNDR-261 Software Update Complete

After power-cycling the SV-XPNDR-261, the STATUS changes as shown in the figure below. The SV-XPNDR-261 is online, with the newer version of Software loaded.



Figure 104: SV-XPNDR-261 Online with Updated Software (Normal Operation)

14.6 SV-XPNDR-261 Post Installation Checks



If an SV-XPNDR-261 is newly-installed (has never flown), aviation authorities typically require that, prior to first flight, a newly-installed transponder be tested for proper operation (and pass).

Aviation authorities also typically require that a transponder be re-tested after any significant maintenance involving the transponder system (including the antenna), and tested periodically (even if no maintenance has occurred). For US pilots, transponders must be tested every twenty-four (24) months – reference FAR 91.413 (other sections, other regulations may apply).

It is the pilot's / aircraft owner's responsibility to ensure that the transponder has been initially, and periodically, tested per (and met) the requirements of your country's aviation authority.

Post installation checks should be carried out in accordance with your certification requirements. These checks should include:

- Mode S interrogations to verify correct address programming.
- Verification of the reported altitude using a static tester.

- Where installed, verification of correct squat switch ground/airborne indications. In an aircraft with a squat switch, setting the Mode switch to ALT when the aircraft is on the ground should leave the SV-XPNDR-261 in GND mode; when the aircraft becomes airborne, the mode should switch automatically to ALT.
- Interrogations to verify the receiver sensitivity. A Mode S transponder should have a minimum triggering level (MTL) of between -77 dBm and -71 dBm. Failure to meet this requirement usually indicates antenna or coaxial cable problems.
- Interrogations to verify the transmitted power. A Class 1 installation should have no less than 125 Watts at the antenna (and no more than 500 Watts). A Class 2 installation should have no less than 71 Watts at the antenna (and no more than 500 Watts). Failure to meet this requirement is also generally due to antenna or wiring issues.
- Where installed, verification of the GPS position source and ADS-B outputs. Whenever a valid position is received by the transponder and the transponder is in any mode other than Standby, ADS-B Extended Squitter should be observed on the transponder test set.
- Ensure all regulatory requirements are met. In the United States, the transponder must be tested and inspected per FAR 91.413.

14.7 Transponder Warnings (Transponder Self Diagnostics)

The SV-XPNDR-261 includes limited self-diagnostic capability. If an SV-XPNDR-261 fault is detected, a system message will be displayed: XPNDR WARNING MESSAGE. To see the detailed information on the fault, go to SETUP MENU > TRANSPONDER SETUP. The words **TRANSPONDER WARNING** will be displayed in Yellow; right-click the knob and see the specific warning. The table below provides a recommendation for each specific warning.

Table 41 – SV-XPNDR-261 Self Diagnostic Messages

Message	Message Explanation	Recommendation
ANT FAULT (value)	Antenna Fault: value is Power output.	Generally, this is an installation issue with antenna, feedline, or the connector. Check the antenna, feedline, or connector. A visual inspection is often not sufficient to find the fault with the antenna, feedline, or connector.
NO ADSB POSITION	GPS data is not being received by transponder.	Check connection to GPS receiver or transponder configuration.
DPSK UNLOCK	Internal diagnostic warning.	Internal fault, contact Dynon Avionics Technical Support to arrange for repair or replacement.

Message	Message Explanation	Recommendation
REMOTE HOT (value)	Transponder is receiving excessive heat; value is Temperature (°C).	Check location of transponder for exposure to excessive heat.
RX PSU FAIL	Internal diagnostic warning.	Internal fault, contact Dynon Avionics Technical Support to arrange for repair or replacement.
SQUITTER FAIL	Extended Squitter data not transmitted.	Internal fault, contact Dynon Avionics Technical Support to arrange for repair or replacement.
TX POWER LOW (value)	Transmit power output is low; value is Power output.	Generally, this is an installation issue with antenna, feedline, or the connector. Check the antenna, feedline, or connector. A visual inspection is often not sufficient to find the fault with the antenna, feedline, or connector.
TX PSU HIGH (value)	Transmitter power supply output is abnormally high; value is Volts.	Internal fault, contact Dynon Avionics Technical Support to arrange for repair or replacement.
TX PSU LOW (value)	Transmitter power supply output is abnormally low; value is Volts.	Check power being supplied to SV-XPNDR-261.
TX RESTART	Internal diagnostic warning	Remove and re-apply power to transponder.
TXPNDR FAULT	Generic fault message	Internal fault, contact Dynon Avionics Technical Support to arrange for repair or replacement.

14.8 Performing Transponder Checks

Transponder checks require manual switching to ALT and GND mode.

A Dynon Avionics SV-XPNDR-261 is normally configured to automatically switch between GND and ALT mode based on airspeed and other parameters – SETUP MENU > TRANSPONDER SETUP > AUTO ALT/GND > AUTOMATIC (AIR DATA). In this mode, in the XPNDR menu, the GND button does not appear, and the ALT button will not change mode unless you are in flight.

Note that some aircraft may be equipped with a squat switch for transponder mode control; before changing AUTO ALT/GND, record which squat switch configuration is set. You will need this information to restore AUTO ALT/GND to this setting after transponder testing is complete.

To be able to manually switch the SV-XPNDR-261 between ALT and GND mode, you must temporarily reconfigure the transponder: SETUP MENU > TRANSPONDER SETUP > AUTO ALT/GND > NONE > EXIT (button).

The SV-XNDR-261 can now be manually switched to ALT and GND modes: XPNDR > ALT and XPNDR > GND.



After transponder testing is complete, remember to return the transponder to its normal configuration: (typically) SETUP MENU > TRANSPONDER SETUP > AUTO ALT/GND > AUTOMATIC (AIR DATA) or the squat switch configuration as previously recorded.

Dynon Avionics SV- SV-GPS-2020 Compliance Statements

Use of Dynon Avionics SV-GPS-2020 as a GPS Position Source for US ADS-B Out

A SkyView system equipped with an SV-GPS-2020 as a position source and an SV-XPNDR-261 as the ADS-B transmitter meets the minimum performance requirements in 14 CFR § 91.227 for operation in the airspaces as defined by 14 CFR § 91.225 when installed and configured per the instructions in this document.

Figure 105: SV-GPS-2020 14 CFR § 91.227 Compliance Statement

15 SV-ARINC-429 ARINC Module

SkyView can connect to advanced GPS/NAV devices like the Garmin GNS 430/530 and similar via the SV-ARINC-429 module.

15.1 Mechanical Installation

Observe the following guidelines when choosing a location for the SV-ARINC-429 module:

- Avoid locations that are subject to severe vibration.
- Avoid locations that are subject to extreme humidity.
- Leave ample working room for electrical connections.
- SkyView systems support one (1) or two (2) SV-ARINC-429 per network.
- A common location for the SV-ARINC-429 is behind the instrument panel, keeping it close to the display and associated ARINC-429 capable device.

The diagram below shows the important mounting dimensions of the SV-ARINC-429 module with electronic connections.

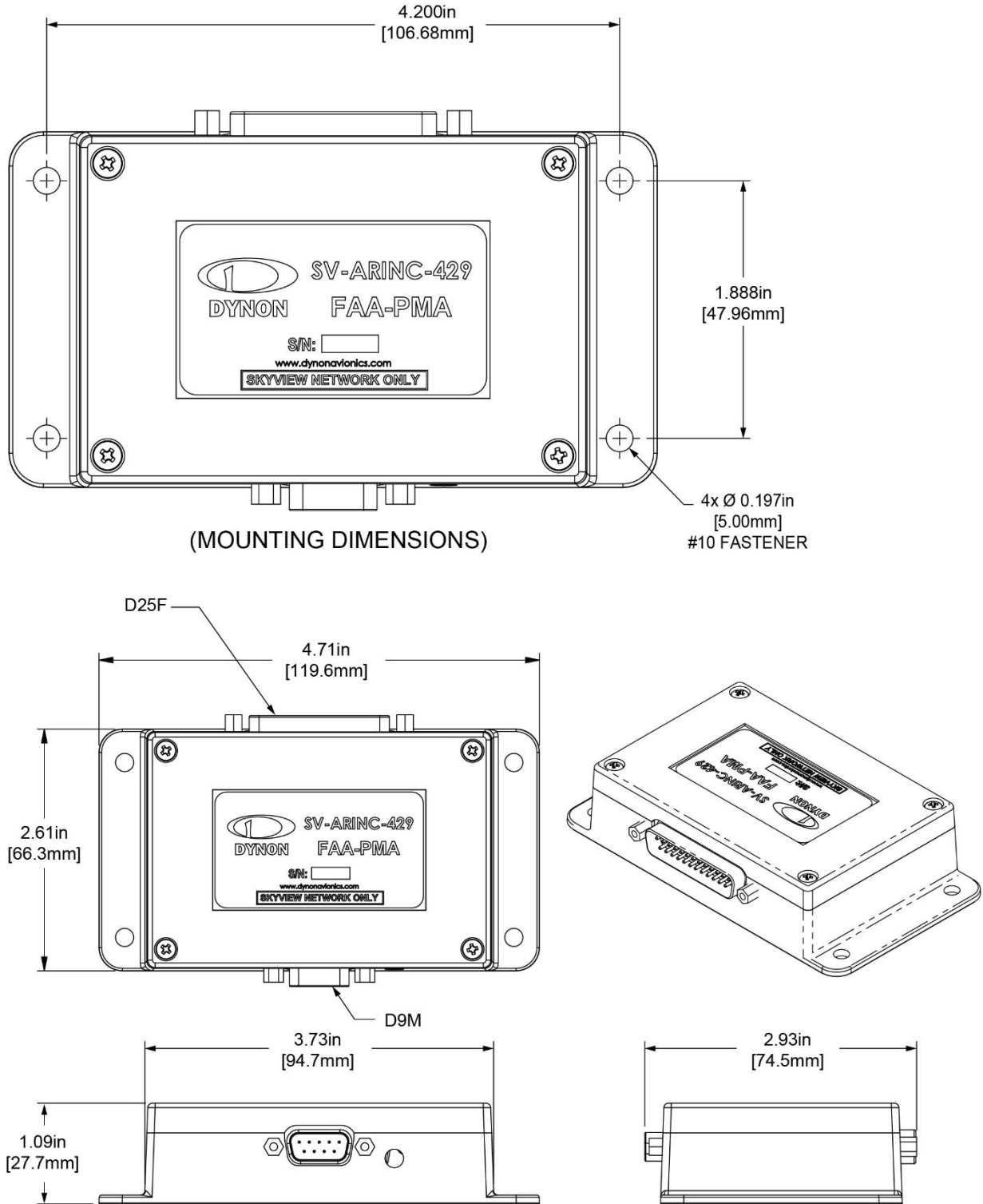

Figure 106: SV-ARINC-429 Mounting Dimensions with Electrical Connections

The SV-ARINC-429 does not provide mounting hardware. The mounting tabs on each side of the module have holes sized for #10 fasteners, but it is up to the installer to decide how the SV-ARINC-429 will be secured to the aircraft.

Follow recommended torque practices when tightening the mounting hardware. *Do not rivet the SV-ARINC-429 to the aircraft as this will hinder future removal if necessary.*

15.2 Electrical Installation

Connect the SV-ARINC-429 module to the SkyView network the cabling mentioned in Section 3.4: Wire Harnesses & Network Cables or using equivalent.

If you have to install a connector on the end of a network cable, insert all pins into the D9 connector. Refer to Section 31 *Appendix C: Wiring and Electrical Connections* for details on connector pinouts and wire colors.

15.2.1 ARINC-429 SkyView Connection

15.2.1.1 Harness Construction

Because the SV-ARINC-429 can be connected to a variety of devices, the harness requirements will vary from airplane to airplane. Therefore, Dynon Avionics does not supply pre-manufactured harnesses for the SV-ARINC-429 module. Instead, your SV-ARINC-429 shipped with enough connectors and pins to generate a wide variety of harness configurations. Refer to the sections below for detailed wiring information.

If you do not own a DSUB machined-pin crimping tool, they can be obtained from many electronics or avionics dealers. You may also find it helpful to own a pin insertion/extraction tool as well.

Additional harness construction and wiring information can be found in Section 31 *Appendix C: Wiring and Electrical Connections*.

The SV-ARINC-429 has a single D25F connector which is used for all data connections to your compatible ARINC-429 device. The pin out depicted in Figure 107 below depicts the view from the rear of your D25M connector – the view you will have of your harness connector as you are inserting pins into the harness. Note that the pin numbers are labelled on the face of both the female and male connector.

15.2.1.2 SV-ARINC-429 Pinout

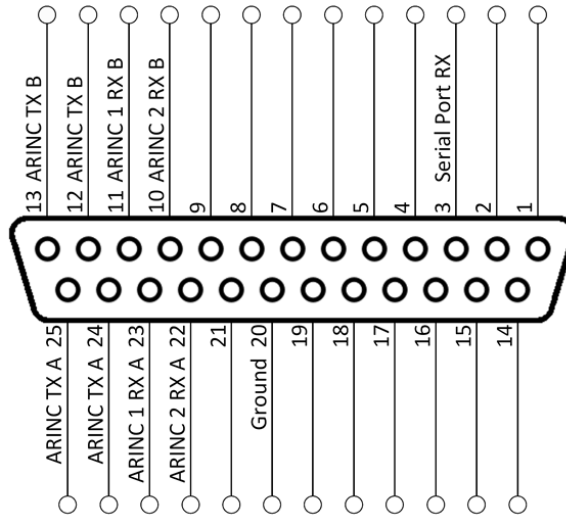

Figure 107: SV-ARINC-429 D25M Pin Insertion View (Rear)

Table 42: SV-ARINC-429 Pinout

Pin	Function	Notes
1	No Connect	-
2	No Connect	-
3	Serial RX	Aviation Format Only from Connected ARINC-429 GPS
4	No Connect	-
5	No Connect	-
6	No Connect	-
7	No Connect	-
8	No Connect	-
9	No Connect	-
10	ARINC 2 RX B	-
11	ARINC 1 RX B	-
12	ARINC TX B	Pins 12/13 are the same TX signal. Provided for convenience when connecting to multiple ARINC receivers.
13	ARINC TX B	Pins 12/13 are the same TX signal. Provided for convenience when connecting multiple ARINC receivers.
14	No Connect	-
15	No Connect	-
16	No Connect	-
17	No Connect	-
18	No Connect	-
19	No Connect	-
20	Ground	-
21	No Connect	-
22	ARINC 2 RX A	-

Pin	Function	Notes
23	ARINC 1 RX A	-
24	ARINC TX A	Pins 24/25 are the same TX signal. Provided for convenience when connecting multiple ARINC receivers.
25	ARINC TX A	Pins 24/25 are the same TX signal. Provided for convenience when connecting multiple ARINC receivers.

15.2.2 ARINC-429 Third-Party Connection

See the 104215-000 SkyView Third Party Connection and Configuration Reference for information about ARINC-429 connection to third-party devices.

15.3 SV-ARINC-429 Related Settings

Go to the ARINC-429 SETUP under SETUP MENU > SYSTEM SETUP > ARINC-429.

SkyView supports up to two (2) SV-ARINC-429 modules, but since most aircraft will only have one (1) installed, the "MODULE 2" section is normally disabled. If your aircraft does actually have two (2) SV-ARINC-429 modules, note that the serial numbers of each module are provided so you can determine which module is which.

For each module, Set INPUT1 to the type of device connected to the SV-ARINC-429's ARINC-429 RX 1 A and B inputs, any of GPS 1, 2, 3, 4 or NAV 1, 2, 3, 4. Optionally, you can specify a "friendly" name for each navigation source using the NAVIGATION SOURCE DISP NAME and specifying up to 7 characters. Examples include "430NAV", and "430GPS". If a NAVIGATION SOURCE DISP NAME is specified, that will be displayed on the HSI. If NAVIGATION SOURCE DISP NAME is not specified, GPS 1,2,3,4 / NAV 1, 2, 3, 4 will be displayed in the info item next to the HSI. For IFR GPS navigators, particularly the Garmin GNS and GTN series, it is also used to describe the device at the top of the Flight Plan window. Note that any GPS/NAV slots that are highlighted in red are already being used for other devices. Also note that though POS X is a possible setting, it should generally not be used for ARINC devices.

Next set the INPUT SPEED parameter (HIGH or LOW), based on the output speed of your two (2) ARINC devices.

The SV-ARINC-429 has one (1) ARINC output channel with 2 sets of pins on the connector for wiring convenience. If one (1) or both of your ARINC devices can accept commands, configure OUTPUT SPEED appropriately.

If you have connected a device to ARINC-429 RX 2 A and B, repeat the above configuration for the INPUT2 parameter; otherwise, leave it set to NONE.

ALLOW AUTO SWITCH: YES (LABEL 100P) / NO: If set to YES (LABEL 100P), SkyView will automatically change whether data from INPUT1 or INPUT2 will be displayed.

- If the source transmits the "100P" label (such as Garmin 430/530/GTN series), SkyView will automatically switch inputs per the label. This allows the inputs to be remotely switched by data from the source, either when the CDI is changed, or automatic transition on approach.

- If data is being transmitted to INPUT1, but no data is being transmitted to INPUT2, INPUT1 will be displayed.
- If data is being transmitted to INPUT2, but no data is being transmitted to INPUT1, INPUT2 will be displayed.

Your ARINC-429 capable GPS and/or NAV will need to be configured appropriately as well.

16 SV-ADSB-472 ADS-B IN Receiver

SkyView can receive traffic and weather via the SV-ADSB-472 UAT Dual Band ADS-B Traffic and Weather Receiver. The SV-ADSB-472 is a remote mounted module that connects to SkyView via a serial port on your SkyView display(s). It also requires the installation of a dedicated antenna for ADS-B signal reception.



The SV-ADSB-472 receives weather via the 978 MHz UAT ADS-B frequencies, which are only utilized in the US. Therefore, weather is only available in the US. Dynon Avionics does not recommend the use of the SV-ADSB-470 outside the US. However, the SV-ADSB-472 does show 1090 MHz ADS-B traffic from other ADS-B equipped aircraft outside the US.



Although weather and TFR information (FIS-B services) available any time the SV-ADSB-472 is in an ADS-B ground station coverage area, ADS-R TIS-B traffic is only available if an SV-XPNDR-261 with ADS-B OUT capability is installed and is providing ADS-B OUT position reports into the ADS-B system.



To enable ADS-B Traffic information on the SV-ADSB-472 with an ADS-B OUT device other than the Dynon Avionics SV-XPNDR-261:

1. SETUP MENU > SYSTEM SETUP > AIRCRAFT INFORMATION > TRANSPONDER HEX CODE > (enter the HEX Code assigned to your aircraft) > ACCEPT (button)
2. SETUP MENU > SYSTEM SETUP > TRAFFIC SETUP > NON-DYNON ADS-B OUT ONBOARD > YES

Only ADS-B OUT devices that comply with TSO C166b or later of the ADS-B spec will allow traffic to be displayed properly. The ADS-B OUT device must be set up to tell the ADS-B system that the aircraft is receiving on 978 MHz.

16.1 Mechanical Installation

The SV-ADSB-472 is designed to be mounted on the avionics tray. If it's not possible to mount on avionics tray, any convenient location in the cockpit, the cabin, or an avionics bay.

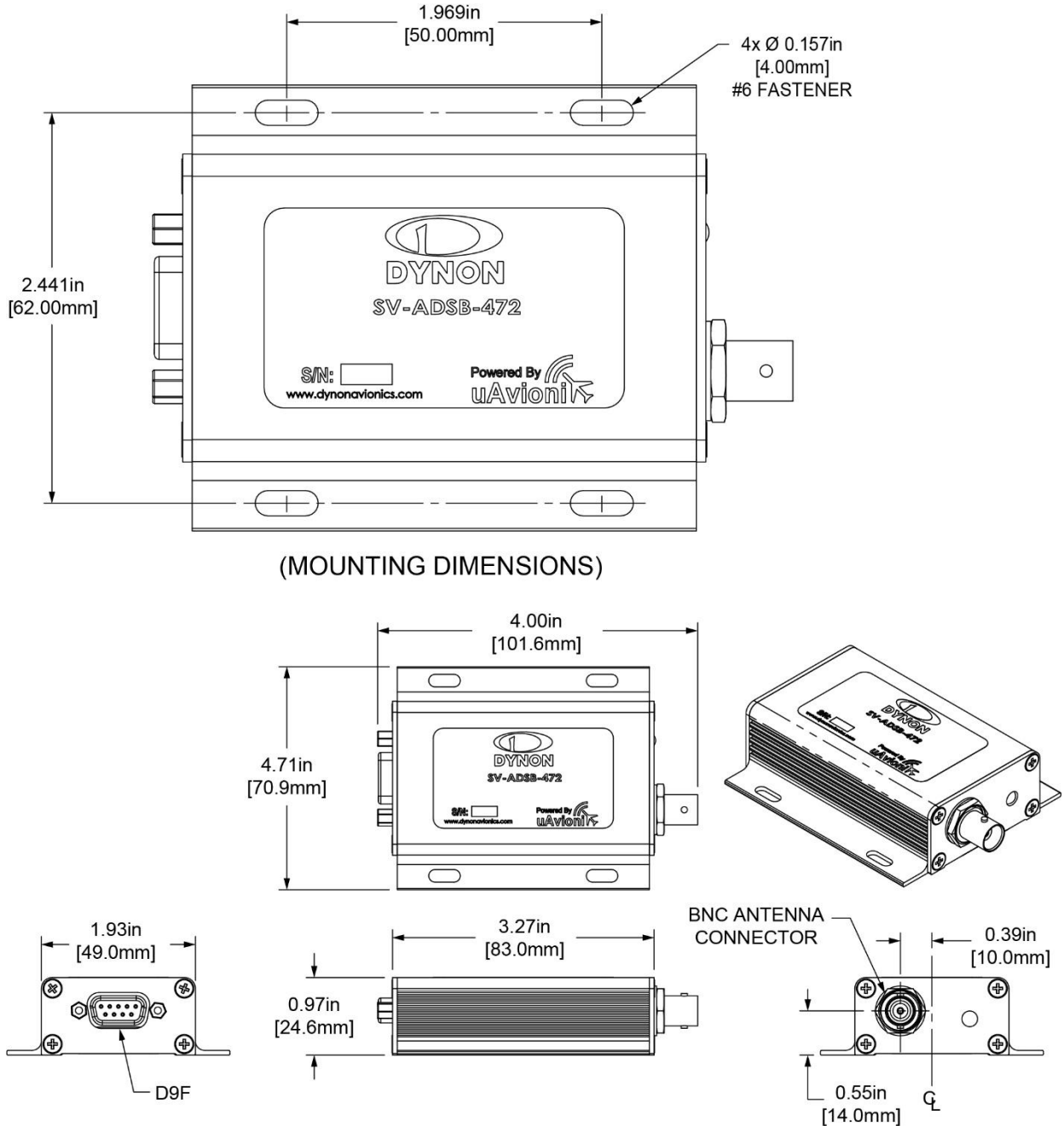

Figure 108: SV-ADSB-472 Mounting Dimensions with Electrical Connections

The following guidelines should be followed, remembering to allow adequate space for installation of cables and connectors:

- Select a position in the aircraft that is not too close to any high external heat source. (The SV-ADSB-472 is not a significant heat source itself and does not need to be kept away from other devices for this reason).
- Avoid sharp bends and placing the cables too near to the aircraft control cables.
- Avoid locations that are subject to severe vibration.
- Avoid locations that are subject to extreme humidity.
- Leave ample working room for electrical connections.

16.1.1 Installation Instructions

The SV-ADSB-472 is designed to be mounted in any convenient location in the cockpit, the cabin, or an avionics bay.

The following installation procedure should be followed, remembering to allow adequate space for installation of cables and connectors:

- Select a position in the aircraft that is not too close to any high external heat source. (The SV-ADSB-472 is not a significant heat source itself and does not need to be kept away from other devices for this reason).
- Avoid sharp bends and placing the cables too near to the aircraft control cables.
- Secure the SV-ADSB-472 to the aircraft using its four (4) mounting holes. The device should be mounted to a flat surface. The mounting tabs on each side of the module have holes sized for #8-32 fasteners. It is up to the installer to decide how the module will be secured to the aircraft.

Additional items you will require, but which are not in the SV-ADSB-472 package, include:

- SV-HARNESS-ADSB (or equivalent harness assembled by installer)
- Antenna and fixing hardware. Antenna selection suggestions are available in the following section.
- Antenna cable and BNC Male connector. You need to supply and fabricate all required antenna cables (or provided as part of your ADS-B antenna). Guidance on cable types is given below.
- Mounting hardware: To secure the SV-ADSB-472 to the aircraft.

16.2 Electrical Installation

For connecting the SV-ADSB-472 to your SkyView system, Dynon Avionics offers the optional SV-HARNESS-ADSB harness (pictured at right). This harness is not included with the SV-ADSB-472. It comes with 15 feet (4.572 m) of wire, and the connector is pre-wired. If required, the harness can be shortened, or lengthened (length is not critical). Table 43: SV-HARNESS-ADSB (below) reflects the wiring colors of the SV-HARNESS-ADSB.



Figure 109: SV-HARNESS-ADSB

Additional harness construction and wiring information can be found in Section 31 *Appendix C: Wiring and Electrical Connections*.

The SV-ADSB-472 has a single D9F connector which provides the data and power inputs to the module. A single BNC connector attaches to the antenna.

16.2.1 SV-HARNESS-ADSB – Pinout (D9F on module / D9M on harness)

Table 43: SV-HARNESS-ADSB Wiring

Pin	Color	Function	Notes
1	Red	10-30V DC	Connect to Aircraft Power
2	Orange	SV-ADSB-472 Serial RX	Data Input from SkyView Display(s): Serial 1 – Pin 4 (Brown / Orange), or Serial 2 – Pin 6 (Yellow / Orange), or Serial 3 – Pin 8 (Green / Orange), or Serial 4 – Pin 10 (Blue / Orange)
3	Violet	SV-ADSB-472 Serial TX	Data Output to SkyView Display(s): Serial 1 – Pin 3 (Brown / Violet), or Serial 2 – Pin 5 (Yellow / Violet), or Serial 3 – Pin 7 (Green / Violet), or Serial 4 – Pin 9 (Blue / Violet)
4	Black	Ground	Connect to Aircraft Ground
5	N/A	No Connection	-
6	N/A	No Connection	-
7	N/A	No Connection	-
8	N/A	No Connection	-
9	N/A	No Connection	-

The pin out depicted in Figure 110 depicts the view from the rear of your D9M connector – the view you will have of your harness connector as you are inserting pins into the harness. Note that the pin numbers are labelled on the face of both the female and male connector.

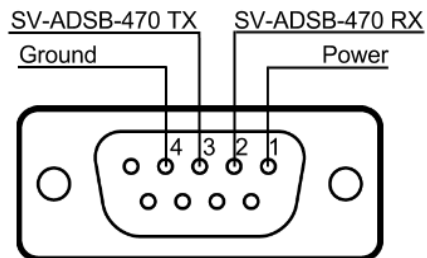

**Figure 110: SV-ADSB-472 Connector Diagram
(From Rear of D9M Connector on the SV-ADSB-HARNESS)**

The information in the table below shows the connections for each of SkyView’s nominally available serial ports (serial port 5 is usually used for connection to the SV-GPS-2020 module). Only ONE (1) of the following serial ports will be used:

Table 44: Example SkyView/SV-ADSB-472 Serial Port Connections

Serial Port	SkyView D37	SV-ADSB-472 D9
1	Pin 3 (RX) Brown/Violet	Pin 3 (TX)
	Pin 4 (TX) Brown/Orange	Pin 2 (RX)
2	Pin 5 (RX) Yellow/Violet	Pin 3 (TX)
	Pin 6 (TX) Yellow/Orange	Pin 2 (RX)
3	Pin 7 (RX) Green/Violet	Pin 3 (TX)
	Pin 8 (TX) Green/Orange	Pin 2 (RX)
4	Pin 9 (RX) Blue/Violet	Pin 3 (TX)
	Pin 10 (TX) Blue/Orange	Pin 2 (RX)

16.2.2 Power/Ground Input

The SV-ADSB-472 can be powered by 10-30 Volts DC. 22 AWG wire is sufficient for wire runs up to 50 feet (15.24 m) for this application. Note that the SV-ADSB-472 must be connected to aircraft power – none of SkyView’s voltage outputs can provide enough power to power the SV-ADSB-472.

Table 45: SV-XPNDR-261 Power Consumption

Power Specifications	Approximate current consumption at 12 volts DC	Approximate current consumption at 24 volts DC
SV-ADSB-472	0.1 amps	0.05 amps

16.2.3 Serial RX/TX

All communication between the SV-ADSB-472 module and SkyView is accomplished via a single bidirectional serial connection. To accomplish this:

- Choose an unused serial port on each display to connect the SV-ADSB-472 to. Note that both the TX and RX sides of the serial port are needed, and both the RX and TX lines must be connected to all displays in parallel. The same numerical serial port must be used on each display.
- Connect the SV-ADSB-472 TX wire (pin 3) to the SkyView serial RX of your choosing. If you have multiple displays, the SV-ADSB-472 TX wire must be connected to the same serial RX wire on each display.
- Connect the SV-ADSB-472 RX wire (pin 2) to the SkyView serial TX of your choosing. If you have multiple displays, the SV-ADSB-472 RX wire must be connected to the same serial TX wire on each display.
- Record the SkyView serial port that you have chosen on each display as you will need to configure it later for use with the SV-ADSB-472.



The SV-ADSB-472 communicates with the SkyView system using serial ports, not SkyView Network. Thus, the SV-ADSB-472 will not be listed as a device in the list of SkyView Network devices (such as SV-ADAHRS-200/201, SV-EMS-220, etc.) This is normal.

16.3 Antenna Selection and Installation

Dynon Avionics offers a 978 MHz Rod type antenna (Part #503367-000) suitable for use with the SV-ADSB-472. The 978 MHz Rod type antenna is supplied with a BNC connector. Dynon Avionics does not supply coaxial cables for this antenna.



**Figure 111: Dynon Avionics
978 MHz Antenna**

The Dynon Avionics 978 MHz Rod type antenna is preferred for use with the SV-ADSB-472 receiver. However, any UAT 978 MHz antenna conforming to TSO-C74 is acceptable.

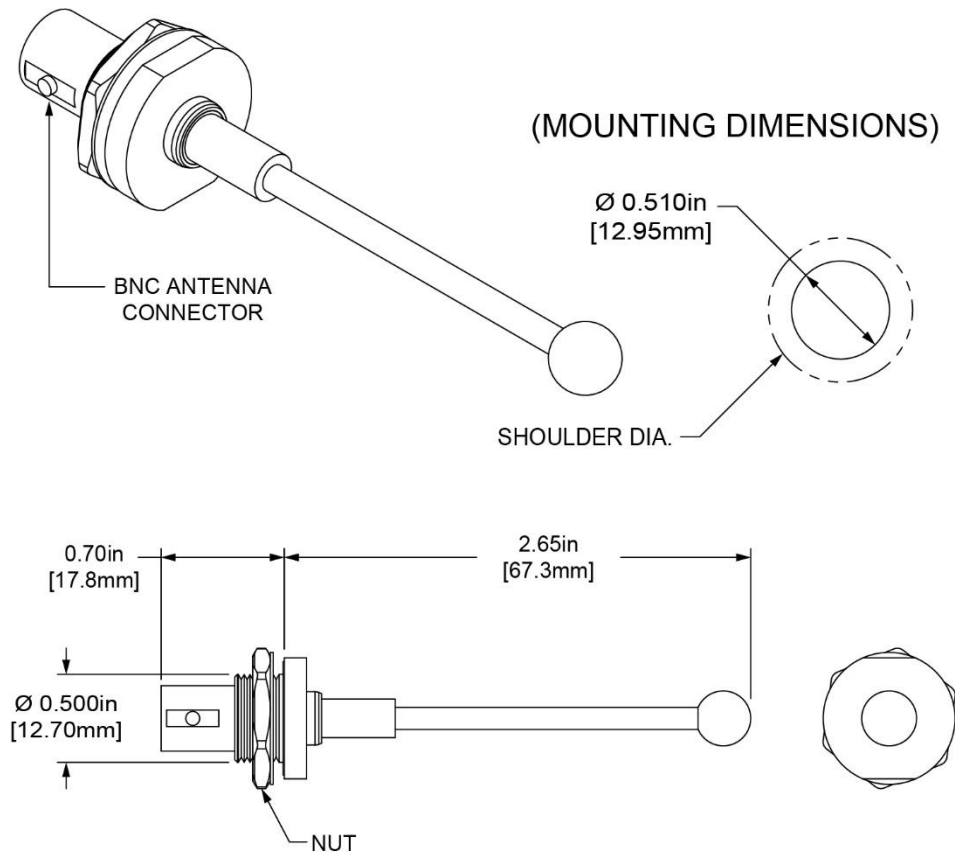

Figure 112: ADS-B Antenna Mounting Dimensions

The following considerations should be considered when siting the antenna:

- The antenna should be well removed from any projections, the engine(s) and propeller(s). It should also be well removed from landing gear doors, access doors or other openings which will break the ground plane for the antenna.
- The antenna should be mounted on the bottom surface of the aircraft and in a vertical position when the aircraft is in level flight.
- Where practical, plan the antenna location to keep the cable lengths as short as possible and avoid sharp bends in the cable to minimize the VSWR (voltage standing wave ratio).
- The SV-ADSB-472 antenna should not be installed within two (2) feet (60.96 cm) of a 1090 MHz transponder (including the SV-XPNDR-261) antenna.

16.3.1 Antenna Ground Plane

When a conventional aircraft monopole antenna is used it relies on a ground plane for correct behaviour. For ideal performance, the ground plane should be very large compared to the wavelength of reception, which is 12.01 inches (305 mm). In a metal skinned aircraft this is usually easy to accomplish but is more difficult in a composite or fabric skinned aircraft. In such cases, a metallic ground plane should be fabricated and fitted under the antenna.

As the ground plane is made smaller, the actual dimensions of the ground plane become more critical, and small multiples of the wavelength should be avoided, as should circles. Rectangles or squares are much less likely to create a critical dimension that resonates with the transmissions. The smallest practical ground plane is a square about 5.12 inches (13.0 cm) per side as the size increases the performance may actually get worse but will be better by the time the ground plane is 30.71 inches (78.0 cm) on each side. Anything much larger than that size is unlikely to show significant further improvement.

The thickness of the material used to construct the ground plane is not critical, providing it is sufficiently conductive. A variety of proprietary mesh and grid solutions are available. Heavyweight cooking foil meets the technical requirements, but obviously needs to be properly supported.

16.3.2 Antenna Cable

An acceptable cable:

- Has less than 3.0 dB loss for the run length needed. For runs less than 17 feet (5.18 m), RG58 is acceptable.
- Has a characteristic impedance of 50 Ω (50 Ohms).
- If running the antenna cable in a bundle with or in close proximity to the SV-XPNDR-261 antenna cable:
 - Has double braid screens or has a foil and braid screen. For runs less than 17 feet (5.18 m), RG400 is acceptable.

When routing the cable, ensure that you:

- Route the cable away from sources of heat.
- Route the cable away from potential interference sources such as ignition wiring, 400Hz generators, fluorescent lighting, and electric motors.
- Keep the cable run as short as possible.
- Avoid routing the cable around tight bends.
- Avoid kinking the cable even temporarily during installation.
- Secure the cable so that it cannot interfere with other systems.

16.3.3 Antenna BNC Female Connector

This section describes the technique for attaching the antenna cable to a BNC Male connector. A BNC Male connector is not supplied with the SV-ADSB-472. The SV-ADSB-472 has a BNC Female connection. Therefore, you will need to source a BNC Male connector that is compatible with the antenna cable type that meets your aircraft’s needs.

A dual crimp style BNC connector can be completed using a wide range of commercial crimp tools (for example the Tyco 5-1814800-3). The die apertures for the inner pin and the outer shield should be approximately 0.069 inches (1.72 mm) and 0.213 inches (5.41 mm) respectively.

- Strip back the coax cable to the dimensions in the table, as shown in the diagram below. Slide 1 inch (25.4 mm) of heat shrink tubing over the cable.
- Slide the outer crimp sleeve over the cable – it must go on before securing the center contact.

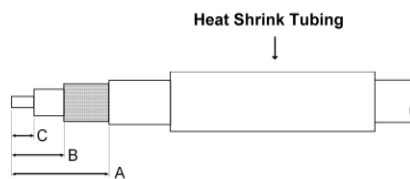

Figure 113: ADSB-472 COAX

Table 46: Example figure of a dual crimp style BNC connector

Dimension	Cut size (mm)	Cut size (inches)
A	17.5	0.69
B	7.2	0.28
C	4.8	0.19

- Crimp the center contact to the cable.
- Insert the cable into the connector – the center contact should click into place in the body, the inner shield should be inside the body of the connector and the outer shield should be outside the body.
- Crimp the outer sleeve over the shield.

Slide heat shrink tubing forward (flush to connector) and heat to shrink the tubing.

16.4 SV-ADSB-472 Related SkyView Display Settings

Before the ADS-B STATUS menu can be accessed, the SV-ADSB-472 needs to be configured on the SkyView system:

SETUP MENU > SYSTEM SETUP > SERIAL PORT SETUP > SERIAL PORT x SETUP (the serial port you wired the SV-ADSB-472 to) > SERIAL IN DEVICE > SV-ADSB-472 > ACCEPT (button).

SETUP MENU > TRAFFIC SETUP > SHOW TAIL NUMBERS > YES > ACCEPT (button).

Other ADS-B Settings:

SETUP MENU > TRAFFIC SETUP > SHOW ADS-B GHOST TARGETS

- NO/YES – hides/shows ghost targets on Map (Default = NO).
- INITIAL RADIUS – radial distance from aircraft in which targets are hidden (Default = 0.25 NM)
- INITIAL ALTITUDE DIFFERENCE – altitude difference between aircraft and target in which target is hidden (DEFAULT = +/- 1000 FT).

16.5 Post Installation Checks

After the SV-ADSB-472 has been configured, confirmation that communication has been established with the module by performing the following procedure:

- Go to SETUP MENU > ADS-B STATUS.
- Confirm that the DEVICE line reads SV-ADSB-472.
- Use the STATUS line to determine whether the SV-ADSB-472 is successfully communicating with SkyView. It can also be used to determine whether the as well as if it is able to see any ADS-B ground stations. The status line can display any of the following states:
 - NOT FOUND: The device is not communicating with SkyView. This usually implies a connectivity/wiring problem between the SV-ADSB-472 and SkyView, or that the SV-ADSB-472 is not receiving power.
 - NO SIGNAL: The device is communicating with SkyView, but data is not being received from an ADS-B ground station. This may occur when you are on the ground and do not have line-of-sight reception of an ADS-B ground station, or if you are in the air and are out of range of all ADS-B ground stations. If there is an ADS-B ground station in range, and NO SIGNAL is persistently displayed, it may imply a connectivity problem with your ADS-B antenna or an installation issue that is preventing the ADS-B antenna from receiving ADS-B ground station broadcasts. Note that when in flight, the Map Page displays a status widget in its lower left corner that contains the same information as this menu status item. That widget will be more useful for ascertaining proper operation once you are in the air and are most likely to be receiving data from ADS-B ground stations.

- RECEIVING: The device is communicating with SkyView AND data is being received from an ADS-B ground station.



If SkyView is not (yet) receiving a valid GPS fix, ADS-B data that is received will not be processed / updated until SkyView does have a valid GPS fix.

- You may also observe the red LED indicator on the SV-ADSB-472 module to confirm proper hardware operation:
 - Flashing Fast: The SV-ADSB-472 is operating normally, is configured and communicating with SkyView over a correctly-configured serial port and is receiving GPS data from SkyView.
 - Flashing Slowly: The SV-ADSB-472 is receiving power and operating normally but is not fully communicating with SkyView.
 - Off: The SV-ADSB-472 is not receiving power.
 - On: The SV-ADSB-472 is receiving power but is not operating normally. Cycle power on the SV-ADSB-472 to try to clear this condition. If the indicator remains On (solid, no blinking), after cycling power, contact Dynon Avionics Technical Support (contact information can be found at the beginning of this manual).

17 SV-COM-X25 and SV-COM-X83 COM Radios

The SV-COM-X25 and SV-COM-X83 are integrated VHF COM radios consisting of two components: the SV-COM-PANEL control panel and the SV-COM-T25 or SV-COM-T8 transceiver. The control panel is installed on an instrument panel, and the transceiver is installed remotely in the airplane. The control panel is available in horizontal and vertical orientations.

The SV-COM-T25 operates at 118.000 MHz to 136.992 MHz with 25 kHz channel spacing. The SV-COM-T8 operates at 118.000 MHz to 136.992 MHz with configurable 8.33 kHz or 25 kHz channel spacing. Both COM radios provide button-touch and numerical frequency tuning. Up to two COM radios can be installed in a SkyView HDX system. If two COM radios are installed, only one can provide frequency information to the SkyView HDX display for presentation on the Info Bar.



Do not transmit without an antenna connected. Doing so will damage your SV-COM-X25/X83 transceiver.

17.1 Mechanical Installation

The figures on the following pages show recommended panel cutouts, mounting hole patterns, and mechanical dimension for the SV-COM-PANEL/V (vertical) and SV-COM-PANEL/H (horizontal). Use these diagrams to plan for the space required by the display.

To mount an SV-COM-PANEL, cut the opening in your panel, drill out the mounting holes, install nutplates, and use the included mounting screws to fasten the display to the panel.

Your SV-COM-X25/X83 is shipped with #6-32 hex-drive round head fasteners. Fasteners are 5/8" long and require a 5/64" hex drive tool. Dynon Avionics recommends fastening the included mounting screws to nut plates installed behind the panel. If access behind the panel allows, standard #6-32 lock nuts or nuts with lock washers can be used. *Do not rivet the SV-COM-PANEL to the panel as this will hinder future removal if necessary.*

The following installation procedure should be followed to install the remote transceiver module, remembering to allow adequate space for installation of cables and connectors.

- If you are installing two COM radios, it is acceptable to co-locate the two transceiver modules.
- Select a position in the aircraft for the transceiver that is not too close to any external high-heat source and where reasonable airflow is available. The transceiver is not a significant heat source itself and does not need to be kept away from other devices for this reason.
- Avoid sharp bends and placing the cables too near to the aircraft control cables.
- Secure the transceiver to the aircraft via the four (4) mounting holes. The unit should be mounted to a flat surface.

Additional items you will require for installation of SV-COM-X25/X83, but which are not in the SV-COM-X25/X83 package, include:

- Nutplates for mounting SV-COM-PANEL to the panel
- To secure the SV-COM-T25/T8 tray to the airframe you will need least 3 flat head screws and three self-locking nuts. If the aircraft does not have existing mounting provisions you may need to fabricate additional brackets to support the tray.
- Circuit breaker or fuse for power to SV-COM-T25/T8 and SV-COM-PANEL
- Power wires to SV-COM-T25/T8
- SV-COM-T25/T8 to SV-COM-PANEL wiring
- SkyView Network cables to connect the SV-COM-PANEL to SkyView Network
- COM Antenna, coaxial cable, terminated to TNC Male connector or cable and TNC Male connector is included with your COM antenna. The SV-COM-T25/T8 is compatible with aircraft COM antennas commonly available (may require a TNC Male to BNC Female adapter).

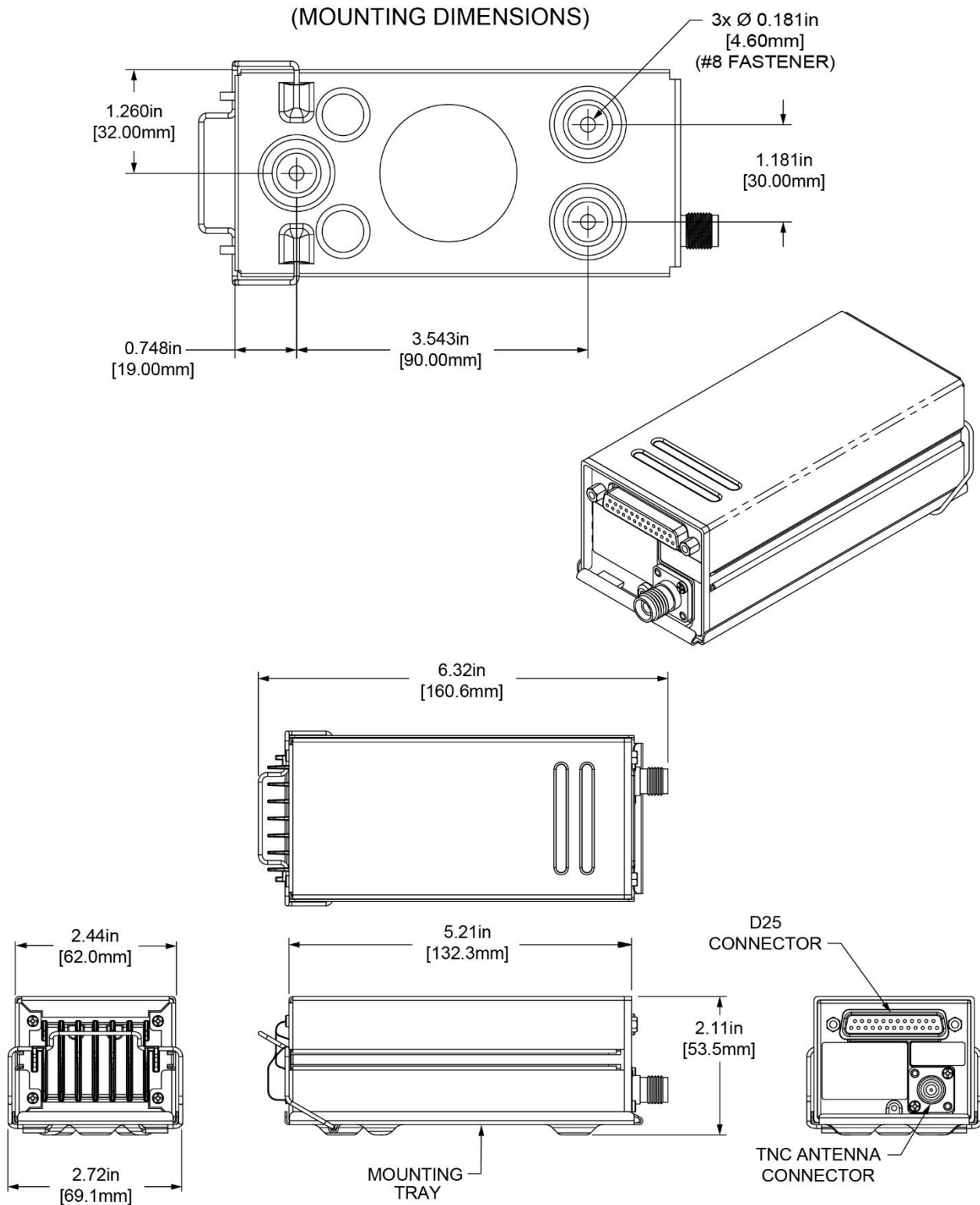

Figure 114: SV-COM-T25/T8 Mounting Dimensions

MOUNTING & CUT-OUT DIMENSIONS

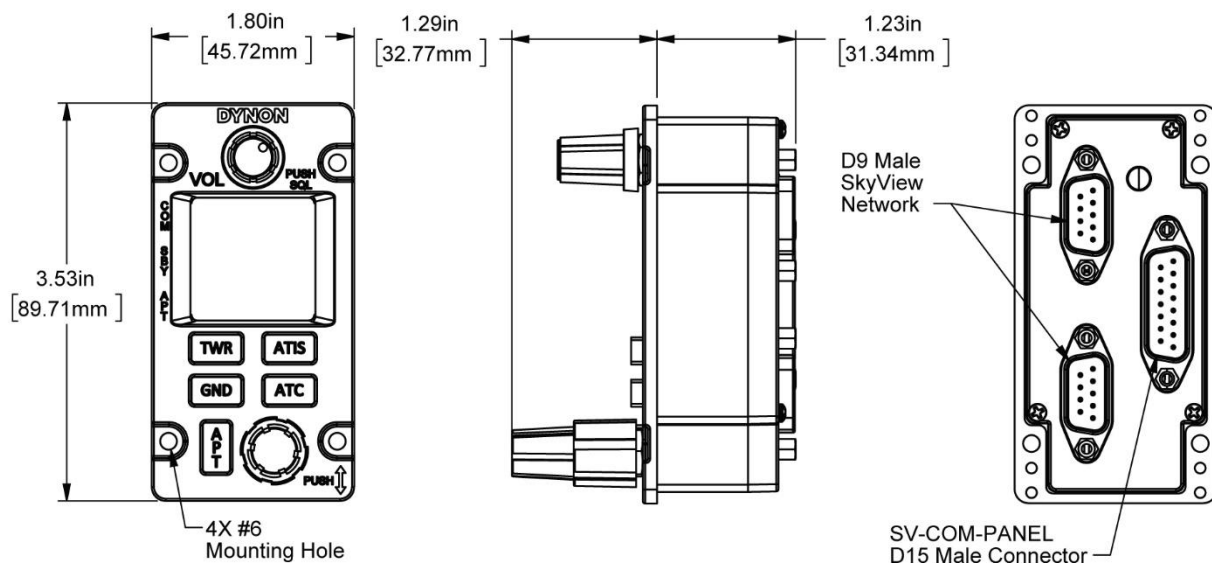
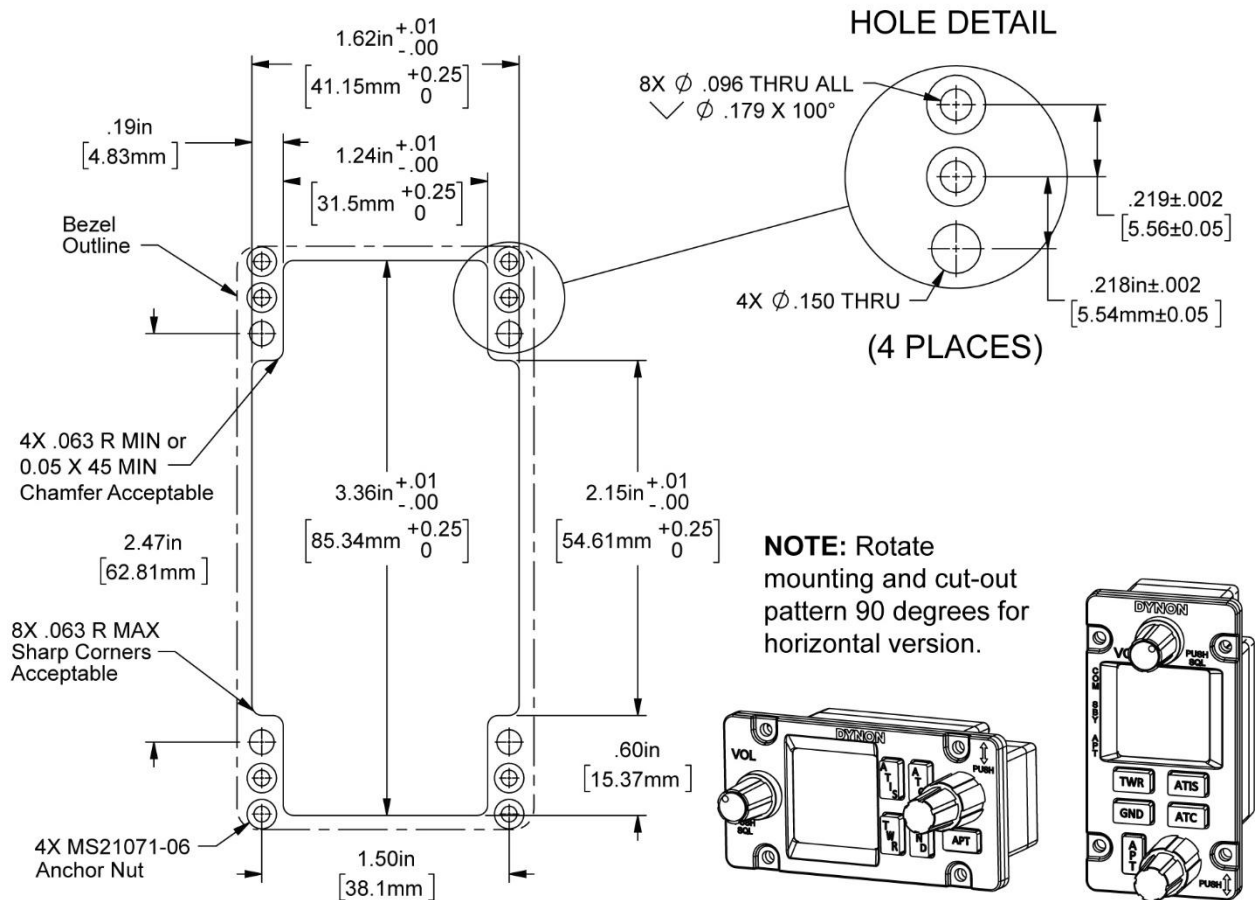

Figure 115: SV-COM-PANEL Mounting Dimensions

17.2 Electrical Installation

Use this section in conjunction with the information contained in Section 31 *Appendix C: Wiring and Electrical Connections*.

17.2.1 Power Input

SV-COM-X25/83 is compatible with 12-volt and 24-volt systems (10 to 30 volts DC). Power input is connected to the transceiver and the SV-COM-PANEL. See wiring diagrams and pinouts for details. Note that the transceiver has two pins for POWER input (Pins 24 and 25) and two pins for GROUND (Pins 19 and 22). Use *both* Pins 24 and 25 for POWER input to the transceiver and use *both* Pins 19 and 22 for GROUND to the transceiver.

17.2.2 Audio Signal Grounding

Ensure that audio input and output grounds terminate at a single point—typically the audio panel. Do not connect an audio input or output ground to aircraft frame ground or a power or data ground. You should run dedicated wires from audio devices to the single point audio input and output ground.

17.2.3 Audio Shielding

Shielded cable must be used for all audio connections. The shield should be connected to ground only at the single point audio ground.

17.2.4 SkyView Network Connectors

The two (2) D9 connectors on the back of an SV-COM-PANEL display are SkyView network connectors. They have identical pinouts and are electrically connected inside the SV-COM-PANEL (i.e., they are completely interchangeable). Installers may use either connector or both connectors in SkyView installations. Using both connectors allows installers to daisy-chain another SkyView Network module (such as the SV-EMS-220) that may be co-located behind the panel. Reference Page 332 for SkyView Network Connector pinout information.



Note that these connectors are not serial port connectors.

17.2.5 Electrical Connections

17.2.5.1 Harness Construction

Because the SV-COM-X25/X83 (SV-COM-PANEL connected to the transceiver) can be mounted in a variety of locations, the harness length requirements will vary from airplane to airplane. Thus, Dynon Avionics does not supply pre-manufactured harnesses for the SV-COM-X25/X83. Instead, your SV-COM-X25/X83 includes connectors and pins to generate a wide variety of harness configurations. Refer to the sections below for detailed wiring information. Additional harness construction and wiring information can be found in Section 31 *Appendix C: Wiring and Electrical Connections*.

The SV-COM-PANEL has two (2) (electrically identical) D9M connectors for connection to SkyView Network and one (1) D15M connector for connection with the transceiver and an optional Frequency Flip/Flop pushbutton input.

The transceiver has one (1) D15M connector for connection to the SV-COM-PANEL, power, audio, and Push to Talk (PTT). A TNC connector attaches to the antenna.

17.2.5.2 SV-COM-PANEL – D15M Pinout

Table 47: SV-COM-PANEL D15M Pinout

Pin	Function	Notes
1	Power In	10-30V DC @ 5A
2	Ground In	Connect to Ground Bus
3	Ground Out	Optional - For Grounding Pin 7 (Flip/Flop Switch). Switch may also be grounded locally.
4	Panel RX / Trans TX	From SV-COM-T25/T8 Pin 6
5	Panel TX / Trans RX	From SV-COM-T25/T8 Pin 5
6	Enable	From SV-COM-T25/T8 Pin 13
7	External Flip/Flop (optional)	Push Button Normally Open to Ground (Pin 3 or local ground)
8	No Connection	(Pin not used)
9	No Connection	(Pin not used)
10	No Connection	(Pin not used)
11	No Connection	(Pin not used)
12	No Connection	(Pin not used)
13	No Connection	(Pin not used)
14	No Connection	(Pin not used)
15	No Connection	(Pin not used)

17.2.5.3 Transceiver – D25M Pinout**Table 48: SV-COM-PANEL D25M Pinout**

Pin	Function	Notes
1	Phones Ground	To Audio Panel
2	Phones Out	To Audio Panel
3	-	Not Used
4	-	Not Used
5	Data RX	SV-COM-PANEL pin 5
6	Data TX	SV-COM-PANEL pin 4
7	-	Not Used
8	-	Not Used
9	MIC/PTT Ground	MIC/PTT shield
10	Ground	
11	-	Not Used
12	-	Not Used
13	SV-COM-PANEL Enable	SV-COM-PANEL pin 6
14	-	Not Used
15	PTT In	Push button normally open (PBNO) to ground
16	-	Not Used
17	-	Not Used
18	Transmit Interlock	Dual SV-COM-X25/X83 installation only
19	Ground In	Airframe ground
20	-	Not Used
21	-	Not Used
22	Ground In	Airframe ground
23	MIC In	From Audio Panel
24	Power In	10-30v dc from source
25	Power In	10-30v dc from source

17.2.5.4 Power/Ground Input

The transceiver and SV-COM-PANEL require 10-30V DC. 20 AWG wire is recommended for power and ground wires for the transceiver. For all other connections, 22 AWG wire is recommended.

Table 49: SV-COM-X25/X83 Power Consumption

Power Specifications	Approximate current consumption at 12 volts DC	Approximate current consumption at 24 volts DC
SV-COM-T25/T8 – Transmit	3.0 Amps (average)	1.5 Amps (average)
SV-COM-T25/T8 – Receive	0.2 Amps (average)	0.1 Amps (average)

Table 50: SV-COM-PANEL to SV-COM-T25/T8 Interconnections

Transceiver Pin	SV-COM-PANEL Pin	Notes
13	6	ENABLE Transceiver -> SV-COM-PANEL
5	5	DATA OUT Transceiver -> SV-COM-T25/T8)
6	4	DATA IN Transceiver -> SV-COM-PANEL

17.2.6 Antenna Installation

Dynon Avionics does not supply COM antennas, radio coaxial cable, or antenna BNC connectors. The antenna (including coaxial cable and connector) should be installed according to the manufacturer’s instructions.

The following considerations should be considered when siting the antenna:

- The antenna should be well removed from any projections, the engine(s) and propeller(s). It should also be well removed from landing gear doors, access doors or other openings which will break the ground plane for the antenna.
- Separation of COM antenna(s) from transponder(s) and GPS receivers / antennas: 1 foot (30.5 cm).
- Separation of COM antenna(s) from Automatic Direction Finder (ADF) or 121.5 MHz Emergency Locator Transmitter (ELT): 4 feet (48 inches) (1.22 m).
- Separation of COM antenna from another COM or NAV antenna: Recommended separation between COM antenna(s), NAV antenna(s), and ELT antennas is 6 feet (72 inches) (1.83 m). Minimum required separation between antennas is 4 feet (48 inches) (1.22 m). Ideally, install the primary COM antenna on the lower fuselage, and install the secondary / standby COM antenna on the upper fuselage.
- The COM antenna(s) should not be installed near SkyView displays, modules, or servos to avoid RF interference.

- Where practical, plan the antenna location to keep the cable lengths as short as possible and avoid sharp bends in the cable to minimize the VSWR (voltage standing wave ratio).
- Double-shielded coaxial cable is superior to single shield coax – more of the transmit power will be coupled to the antenna, and less received signal will be lost.
- Electrical connection to the antenna should be protected to avoid loss of efficiency because of the presence of liquids or moisture. All antenna feeders shall be installed in such a way that a minimum of RF energy is radiated inside the aircraft.

17.2.6.1 Antenna Ground Plane

When a conventional aircraft monopole antenna is used it relies on a ground plane for correct behaviour. For ideal performance, the ground plane should be very large compared to the wavelength of the transmission, which is approx. 7.5 feet (2.29 m). In a metal skinned aircraft this is usually easy to accomplish but is more difficult in a composite or fabric skinned aircraft. In such cases, a metallic ground plane should be fabricated and fitted under the antenna.

As the ground plane is made smaller, the actual dimensions of the ground plane become more critical, and small multiples of the wavelength should be avoided, as should circles. Rectangles or squares are much less likely to create a critical dimension that resonates with the transmissions. The thickness of the material used to construct the ground plane is not critical, providing it is sufficiently conductive. A variety of proprietary mesh and grid solutions are available. Heavyweight cooking foil meets the technical requirements, but obviously needs to be properly supported.

17.2.6.2 Antenna Cable

When routing the cable, ensure that you:

- Route the cable away from sources of heat.
- Avoid routing antenna cables together.
- Route the cable away from potential interference sources such as ignition wiring, 400Hz generators, fluorescent lighting and electric motors.
- Allow a minimum separation of 1 foot / 12 inches (30.5 cm) from an ADF antenna cable.
- Keep the cable run as short as possible.
- Avoid routing the cable around tight bends.
- Avoid kinking the cable even temporarily during installation.
- Secure the cable so that it cannot interfere with other systems.

17.3 SkyView System Settings for SV-COM-X25/X83

17.3.1 Network Setup

As with all other SkyView Network devices, the SV-COM-X25/X83 must be configured into the SkyView Network:

- Go to SETUP MENU > SYSTEM SETUP > SKYVIEW NETWORK SETUP > CONFIGURE > (right click) > DETECT (button).
- The SV-COM-X25/X83 will be listed as SV-COM-PANEL.
- FINISH (button) > EXIT (button).

17.3.2 COM RADIO Setup

To adjust Squelch, Sidetone, and Microphone Gain, go to SETUP MENU > COM RADIO SETUP:

> SQUELCH LEVEL – Adjust squelch level so that the audio is heard during transmissions, and muted when transmissions are not present.

> SIDETONE VOLUME – Adjust for your personal preference of how much microphone audio is heard in the headset when transmitting.



For example, an "unpowered" (conventional) headset may require a MIC GAIN setting of 70 for acceptable audio quality / audio level being transmitted. A noise-cancelling headset with a microphone adjustment may require a MIC GAIN setting of 30 for acceptable audio quality / audio level being transmitted.

> MIC GAIN – The default setting of 50 should work for most installations.

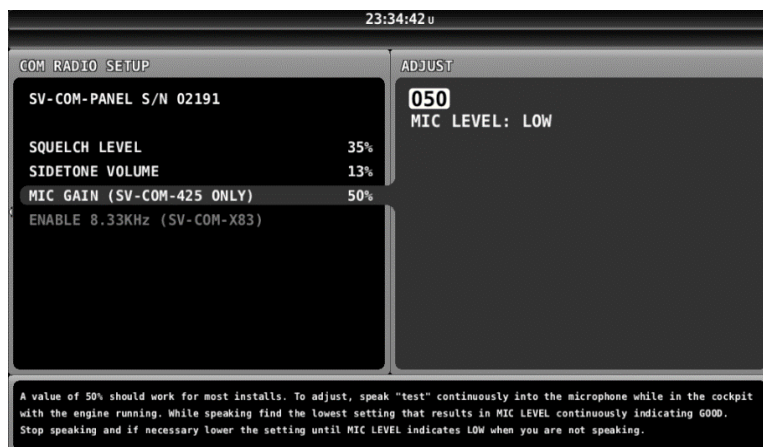

To assist in setting SV-COM-T25/T8 microphone gain, the COM RADIO SETUP > MIC GAIN (SV-COM-T25/T8 ONLY) menu includes a diagnostic feature (MIC LEVEL: LOW / GOOD / HIGH), as shown on screen.

Figure 116: Headset Jack Schematic Interpretation

To adjust, speak "test" continuously into the microphone while in the cockpit with the engine running.

While speaking, find the lowest setting that results in MIC LEVEL continuously indicating GOOD. Stop speaking and if necessary lower the setting until MIC LEVEL indicates LOW when you are not speaking.

In practice, a more reliable method to determine the correct setting of MIC GAIN is to ask a helper to listen on another radio while you talk in brief intervals, allowing for other transmissions to be heard by the helper. For such a test to be valid, depending on the radio, aircraft, antennas, and terrain (buildings), it may be necessary to have some distance between you and the helper (being right next to each other will not be a valid test). With the helper listening on your (not heavily in use) test frequency, adjust MIC GAIN slowly up or down, pausing between transmissions.

For example, set MIC GAIN to 55, speak "*Test1, Test2, Test3, Test4, Test5*", then pause a minute or so for other transmissions to be heard. The helper should reply whether your transmission was weaker, or stronger than the other transmissions. If the helper indicated your transmission was stronger than the other transmissions, adjust MIC GAIN lower, and do another set of transmissions. When the helper hears your audio to be about the same volume as the other transmissions, MIC GAIN is set correctly.

If other people report that your transmissions fade off at the end or can't be heard at all, you may need increase MIC GAIN. If your transmissions are reported to sound "hollow", "robotic" or if they have a lot of background noise, you may need to decrease MIC GAIN. Also note these issues can only be heard on real transmissions by third parties.



The audio you hear in your headset (Sidetone) when you transmit is unaffected by the MIC GAIN setting. As explained above, the best method to set MIC GAIN correctly is to work with a helper who is listening to your transmissions on a different radio.

17.3.2.1 Displayed COM (Top Bar)

The status of one (1) COM radio can be displayed on the top bar. The radio that is selected here is also the radio that you can send airports and frequencies to via SkyView's Map Menu APT>COM and TUNE COM buttons. See the SkyView Pilot's User Guide for additional details.

- Go to **SETUP MENU > SYSTEM SETUP > DISPLAYED COM** and select which COM radio status to display on the Top Bar (or NONE). (To display status of a non-Dynon Avionics radio, a serial port connection must be installed FROM the radio TO the SkyView display(s).

17.4 Post Installation Checks

On ground:

- Do all SV-COM-PANEL buttons and knobs function normally?
- Verify dim commands from SkyView display dim the backlighting of the SV-COM-PANEL.
- Does the (optional) FLIP/FLOP pushbutton swap the STBY and COM frequencies?
- Does pushing the PTT switch cause the SV-COM-X25/X83 to transmit (only) when pushed?



Do not transmit without an antenna connected. Doing so will damage your SV-COM-T25/T8 transceiver.

- (Optional, if two (2) SV-COM-X25/X83s installed) Does the PTT Select Switch cause only the selected radio to transmit when PTT switch is pushed?
- Temporarily install a VSWR meter between the SV-COM-X25/X83 and the antenna. Using brief test transmissions, is the VSWR 3:1 or below? A good installation should have VSWR of 2:1 or even 1:1. *The maximum acceptable VSWR for SV-COM-X25/X83 is 3:1.*
- When transmitting on SV-COM-X25/X83, is there any interference to other aircraft systems?
- Power off the SkyView display(s) by pushing and holding Button #1 on the display. The SV-COM-X25/X83 should continue to operate normally, with the exception that auto-population of the button's frequencies will not occur, and a NO SV error message will appear approx. three (3) seconds after SV is not operating.

In Flight

- Does the SV-COM-X25/X83 receive other aircraft and ground transmissions at reasonable ranges?
- Does the SV-COM-X25/X83 receive other aircraft and ground transmissions equally well at the low end, middle, and high end of the Aviation band?
- Is received audio clear at most volume levels on the SV-COM-X25/X83? (Distortion at high volume levels is normal.)
- Are transmissions from the SV-COM-X25/X83 heard by others at reasonable ranges? (Keep in mind that the power output of the SV-COM-X25/X83 is 6 watts.)
- Are transmissions from the SV-COM-X25/X83 clear (when received by others)?

18 Autopilot Servos

18.1 Overview

The installation of autopilot servos is aircraft-model specific. Not every airplane can receive a Dynon SkyView autopilot. Refer to the AML associated with STC SA02594SE to see if your make and model airplane is eligible for an autopilot installation.

If your airplane is eligible for an autopilot installation, refer the Servo Installation Manual specific to your make and model of airplane for instructions.

18.1.1 Wire Sizing and Installation

While it is beyond the scope of this installation manual to advise on specific types of wiring for a particular aircraft, choice of wiring should be sized to 1) minimize voltage drop over the length of the wiring run, and 2) conduct the amount of current required by the subsystem without the wiring becoming warm to the touch. Section 31 *Appendix C: Wiring and Electrical Connections* contains information and suggested resources for wiring and electrical connections. Generally, 20 AWG wire is a suitable gauge for the servo power / ground wires for lengths up to 20' (6.10 m) of wire.

Care should be taken such that aircraft wiring is not subjected to chafing, excessive flexing, or connections/junctions subjected to excessive vibration which may cause the connection/junction to fail or short-circuit.

18.1.2 Autopilot Master Power

The Autopilot system requires a power supply of 10–30V DC, and power input must be protected with an aviation-grade 10A circuit breaker. (Refer to the *SkyView HDX Wiring Diagram – Single Engine* or the *SkyView HDX Wiring Diagram – Twin Engine* document for more information.)



The Autopilot system must include a switch labeled AP POWER that can remove power from all servos.



The AP POWER switch must be in a prominent position that is easy for the pilot to find and reach in the event of an Autopilot malfunction.

18.1.3 Configuration Files

Airplane-specific servo settings are available for download as configuration files at dynoncertified.com/docs. The configuration file for the airplane needs to be loaded into the SkyView HDX display unit prior to Initial Autopilot Setup. (Refer to Section 27.5: Software Updates and File Operations for file loading instructions.) The file will configure the autopilot servo performance settings to meet applicable certification regulations.

18.2 Autopilot Servo Initial Setup

There are several parameters in the Autopilot Setup Menu (SETUP MENU > AUTOPILOT SETUP) that allow you to tune the behavior of the SkyView autopilot system. This section describes these adjustable parameters. *Note that the Autopilot Setup Menu is only accessible after a successful servo test procedure.*

18.2.1 Autopilot Setup Options

18.2.1.1 Autopilot Controls

SkyView's autopilot can be operated using one (1) of two (2) very distinct control schemes:

SIMPLIFIED: Two (2) button streamlined autopilot controls: TRK+ALT for flying in the direction and at the altitude you choose, HSI+ALT for following navigation sources like GPS flight plans.

EXPERT: Autopilot controls containing the features that IFR pilots need. Includes VNAV, IAS hold, TRK mode, fully-coupled approaches, mode sequencing, and a flight director.



Setting the SkyView AP to EXPERT mode requires that two (2) SkyView AP servos (Roll *and* Pitch) are installed. If only one (1) servo (either Roll only, or Pitch only) is installed, the SkyView AP can only be set to SIMPLIFIED mode.

For more details on the differences between these two (2) sets of controls, see the SkyView Pilot's User Guide.

To set the Autopilot Control scheme:

1. Go to the Autopilot Controls Adjust Page (SETUP MENU > AUTOPILOT SETUP > AUTOPILOT CONTROLS).
2. Choose SIMPLIFIED or EXPERT controls.
3. Press ACCEPT to save the value or press CANCEL to return to the Autopilot Setup Menu.

18.2.1.2 Flight Director (Expert Controls Only)

When Expert controls are used, SkyView displays a flight director that provide autopilot control cues to the pilot. It can be set to one (1) of two (2) visual styles:

SINGLE CUE (INVERTED-V): Uses a single "inverted V" symbol to indicate pitch and roll angles that the autopilot will use to meet its goals. When the autopilot is not engaged, pitch and roll the aircraft to align this symbol with the waterline to fly the airplane like the autopilot would.

DUAL CUE (CROSS BARS): Uses separate horizontal and vertical bars across the attitude indicator to indicate the pitch and roll angles that the autopilot will use to meet its goals. When the autopilot is not engaged, pitch and roll the aircraft to center both the horizontal and vertical bars with the waterline to fly the airplane like the autopilot would.



Figure 117: Flight Director - Single Cue (Inverted-V)



Figure 118: Flight Director - Dual Cue (cross bars)

For more details on Flight Director behavior, see the SkyView Pilot's User Guide.

To set the Flight Director style:

1. Go to the Autopilot Flight Director Adjust Page (SETUP MENU > AUTOPILOT SETUP > FLIGHT DIRECTOR).
2. Choose SINGLE CUE or DUAL CUE.
3. Press ACCEPT to save the value or press CANCEL to return to the Autopilot Setup Menu.

18.2.2 Roll Axis Configuration

18.2.2.1 Roll Axis Torque

The roll axis torque parameter specifies how much torque the servo will exert before slipping. Servo slip is indicated by the word SLIP in black letters in a yellow box on the Top Bar for the roll axis as shown in Figure 119.

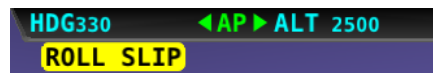

Figure 119: Example Roll Axis Servo Slip Warning

Torque must be set high enough to prevent any slip due to air loads, but low enough that the pilot can comfortably override the autopilot should the need arise. *If the servo slips continuously, the autopilot cannot fly the aircraft.* Torque is specified in percent (%) of maximum the servo is capable of exerting. The minimum is 10%, the maximum is 100%, and the default value is 100%. If you can override the servo at 100% torque, use this default value.

To test roll axis servo override force:

1. Return to the Main Menu.
2. Center the aircraft controls.
3. Enter the Autopilot Menu (MAIN MENU > AUTOPILOT).
4. Press the LEVEL button to engage the autopilot.

Now, take the controls and override the servo by moving to either roll left or roll right. Ensure that you are comfortable with the amount of force it takes to override the servo. If you are not, decrease the roll servo torque value by 10% and repeat the test.

18.2.3 Pitch Axis Configuration

18.2.3.1 Default Climb Vertical Speed

When using simplified autopilot controls, the default climb vertical speed parameter sets the initial vertical speed the autopilot will command for climbs when an altitude change is requested. You may also control the climb vertical speed after a climb is in progress with the vertical speed bug. If you set this parameter above a vertical speed the aircraft can achieve, the autopilot will run into the airspeed limiter in a climb.

When using expert autopilot controls, the Default Climb Vertical Speed is only used when NOSE UP is pressed while ALT HOLD mode is already engaged. This activates VS mode at the Default Climb Vertical Speed.

The default climb vertical speed parameter is specified in the units set in the Measurement Units Menu (i.e., feet per minute or meters per second; reference Page 279 for more information regarding configuring the measurement units). The default value is 500 feet (152.4 m) per minute.

To adjust the default climb vertical speed:

1. Go to the Pitch Axis Default Climb Vertical Speed Adjust Page (SETUP MENU > AUTOPILOT SETUP > PITCH AXIS > DEFAULT CLIMB VERTICAL SPEED).
2. Adjust the default climb vertical speed.
3. Press ACCEPT to save the value or press CANCEL to return to the Pitch Axis Menu.

18.2.3.2 Default Descent Vertical Speed

When using simplified autopilot controls, the default descent vertical speed parameter sets the initial vertical speed the autopilot will command for descents when an altitude change is requested. You may also control the descent vertical speed after a descent is in progress with the vertical speed bug. If you set this parameter below the vertical speed the aircraft can achieve, the autopilot will run into the airspeed limiter during descent.

When using expert autopilot controls, the Default Descent Vertical Speed is only used when NOSE DOWN is pressed while ALT HOLD mode is already engaged. This activates VS mode at the Default Climb Vertical Speed.

The default descent vertical speed parameter is specified in the units set in the Measurement Units Menu (i.e., feet per minute or meters per second; reference Page 279 for more information regarding configuring the measurement units). The default value is 500 feet (152.4 m) per minute.

To adjust the default descent vertical speed:

1. Go to the Pitch Axis Default Descent Vertical Speed Adjust Page (SETUP MENU > AUTOPILOT SETUP > PITCH AXIS > DEFAULT DESCENT VERTICAL SPEED).
2. Adjust the default descent vertical speed.
3. Press ACCEPT to save the value or press CANCEL to return to the Pitch Axis Menu.

18.2.3.3 Maximum Airspeed



If the AP is engaged and the Maximum Airspeed limit is changed to a value that is lower than the current airspeed, the AP will immediately act to reduce the airspeed to the new maximum airspeed setting and may do so aggressively. Dynon Avionics recommends that this setting only be adjusted with the AP disengaged.

The pitch axis maximum airspeed parameter is the highest airspeed at which the pilot may engage the autopilot. If the autopilot is engaged at the time the aircraft's airspeed exceeds the maximum, the autopilot enters an airspeed hold mode and pitches the aircraft up to prevent increasing airspeed. SkyView simultaneously indicates that the aircraft has exceeded the parameter by displaying SPD indicators in the Top Bar as illustrated in Figure 120.



Figure 120: Top Bar SPD Indicator

If the aircraft's altitude rises above the target altitude bug and the autopilot cannot pitch the aircraft down without going above the maximum airspeed, SkyView presents the prompt:

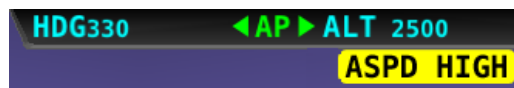

Figure 121; Top Bar Airspeed High Indication

The maximum airspeed parameter cannot be set to a value above 95% of Vne, which should be set to the specifications of your aircraft in the Airspeed Limitations Menu (reference Airspeed Limitations for more information) and is specified in the units set in the Measurement Units Menu (i.e., miles per hour, knots, or kilometers per hour). As mentioned previously, the maximum value for this parameter is 95% of Vne. This is also the default value.

To set the maximum airspeed:

1. Go to the Pitch Axis Maximum Airspeed Adjust Page (SETUP MENU > AUTOPILOT SETUP > PITCH AXIS > MAXIMUM AIRSPEED).
2. Adjust the maximum airspeed.
3. Press ACCEPT to save the value or press CANCEL to return to the Roll Axis Menu.

18.2.3.4 Minimum Airspeed



If the AP is engaged and the Minimum Airspeed limit is changed to a value that is higher than the current airspeed, the AP will immediately act to increase the airspeed to the new minimum airspeed setting. Dynon Avionics recommends that this setting only be adjusted with the AP disengaged.

The pitch axis minimum airspeed is the lowest airspeed at which the pilot may engage the autopilot. *The autopilot cannot be engaged at airspeeds below the minimum airspeed, except for 0 knots (0 km), allowing for ground testing.*

When flying at airspeeds lower than the minimum airspeed or when the autopilot is engaged, and the aircraft airspeed drops below the minimum, SkyView indicates that the aircraft has dropped below the parameter by displaying SPD indicators in the Top Bar as illustrated in Figure 120 above.

If the aircraft's altitude drops below the target altitude bug and the autopilot cannot pitch the aircraft up without dropping below the minimum airspeed, SkyView presents the prompt:

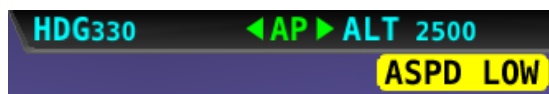

Figure 122: Top Bar Airspeed Low Indication

The minimum airspeed parameter must be set to at least (and defaults to) 30% above VS1, which should be set to the specifications of your aircraft in the Airspeed Limitations Menu (reference Airspeed Limitations for more information) and is specified in the units set in the Measurement Units Menu (i.e., miles per hour, knots, or kilometers per hour). As previously mentioned, the minimum value for this parameter is 30% above VS1. This is also the default value.

To set the minimum airspeed:

1. Go to the Pitch Axis Minimum Airspeed Adjust Page (SETUP MENU > AUTOPILOT SETUP > PITCH AXIS > MINIMUM AIRSPEED).
2. Adjust the minimum airspeed.
3. Press ACCEPT to save the value or press CANCEL to return to the Roll Axis Menu.

18.2.4 Disengage Button Options

Configure the function of the Autopilot Disconnect (Disengage) Button:

1. Go to the Disengage Button options (SETUP MENU > AUTOPILOT SETUP > DISENGAGE BUTTON).
2. Configure Disengage Button settings:
 - A. HOLD TO ENGAGE: NO (default).
 - This feature is prohibited for certified installations.
 - B. ENABLE BROKEN LINE DETECT: select YES or NO (default).
 - Set to YES an optional 5 k Ω resistor is installed across the two terminals of the Disengage Button. When set to YES, SkyView HDX continuously monitors the Disengage circuit for proper resistance. If a broken line is detected, SkyView will display the AP BROKEN DISCONNECT message. If the Autopilot is engaged when this condition is detected, it will remain engaged.
 - Set to NO if a resistor is not installed.
 - C. CONTROL WHEEL STEERING: NO (default).
 - This feature is prohibited for certified installations.
3. Press ACCEPT to save, or press CANCEL to return to the Disengage Button Menu.

19 SV-AP-PANEL Autopilot Control Panel

This section contains pre-installation considerations, installation instructions, and details to install the SV-AP-PANEL/H (Horizontal orientation) and SV-AP-PANEL/V (Vertical orientation). Physically, electronically, and operationally, the two (2) versions are identical, and hereafter referred to SV-AP-PANEL.

The SV-AP-PANEL is an optional control panel for a SkyView system that provides one-button controls for the SkyView Autopilot that are otherwise operated from the SkyView display menu buttons (which are still accessible after the installation of an SV-AP-PANEL). As the SV-AP-PANEL allows for expert autopilot mode controls including IAS, VNAV, and approach sequencing, the buttons on the SV-AP-PANEL are enabled only when the SkyView AP is set to EXPERT mode (SETUP MENU > AUTOPILOT SETUP > AUTOPILOT CONTROLS > EXPERT). Up to two (2) SV-AP-PANELs can be installed in a SkyView system.



Setting the SkyView AP to EXPERT mode requires that two (2) SkyView AP servos (Roll *and* Pitch) are installed.

SV-AP-PANEL NOSE UP and NOSE DN BUTTONS:

The NOSE UP button on the SV-AP-PANEL commands the AP System, if engaged, to incrementally pitch the AP "Nose Up" via IAS or VS adjustments depending on what mode the AP is in.

Similarly, the NOSE DN button on the SV-AP-PANEL commands the AP system, if engaged, to incrementally pitch the AP "Nose Down" via IAS or VS adjustments depending on what mode the AP is in.

The SV-AP-PANEL NOSE UP and NOSE DN buttons command the AP; *these buttons do not command trim controls.*



Figure 123: SV-AP-PANEL UP / DN Buttons

19.1 Mechanical Installation

(MOUNTING & CUT-OUT DIMENSIONS)

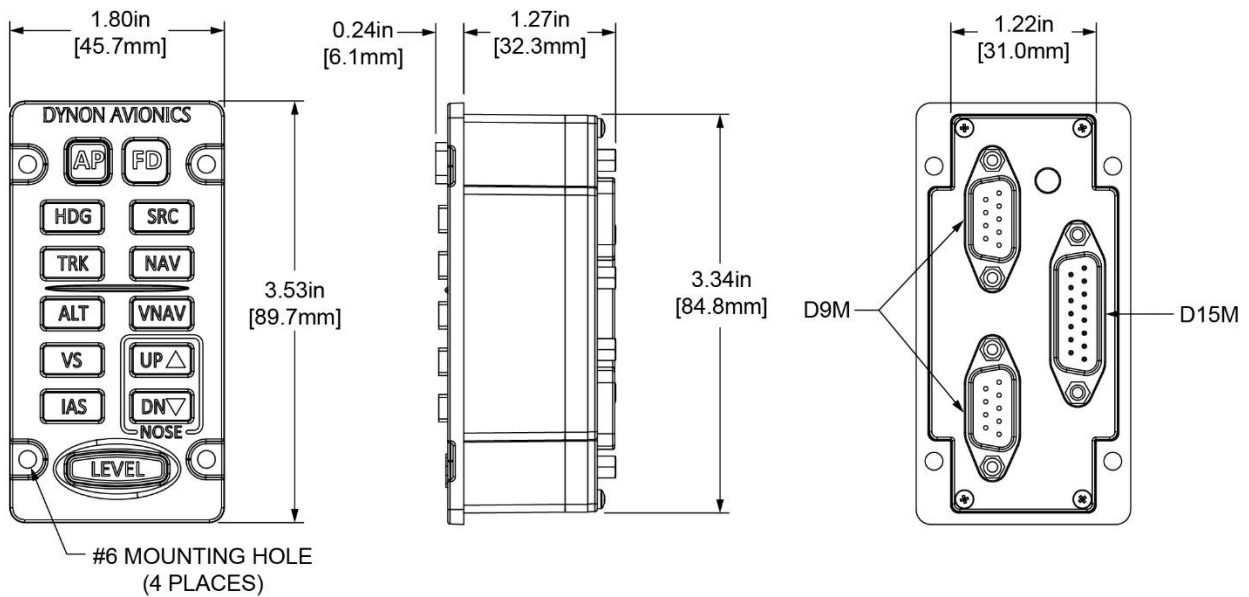
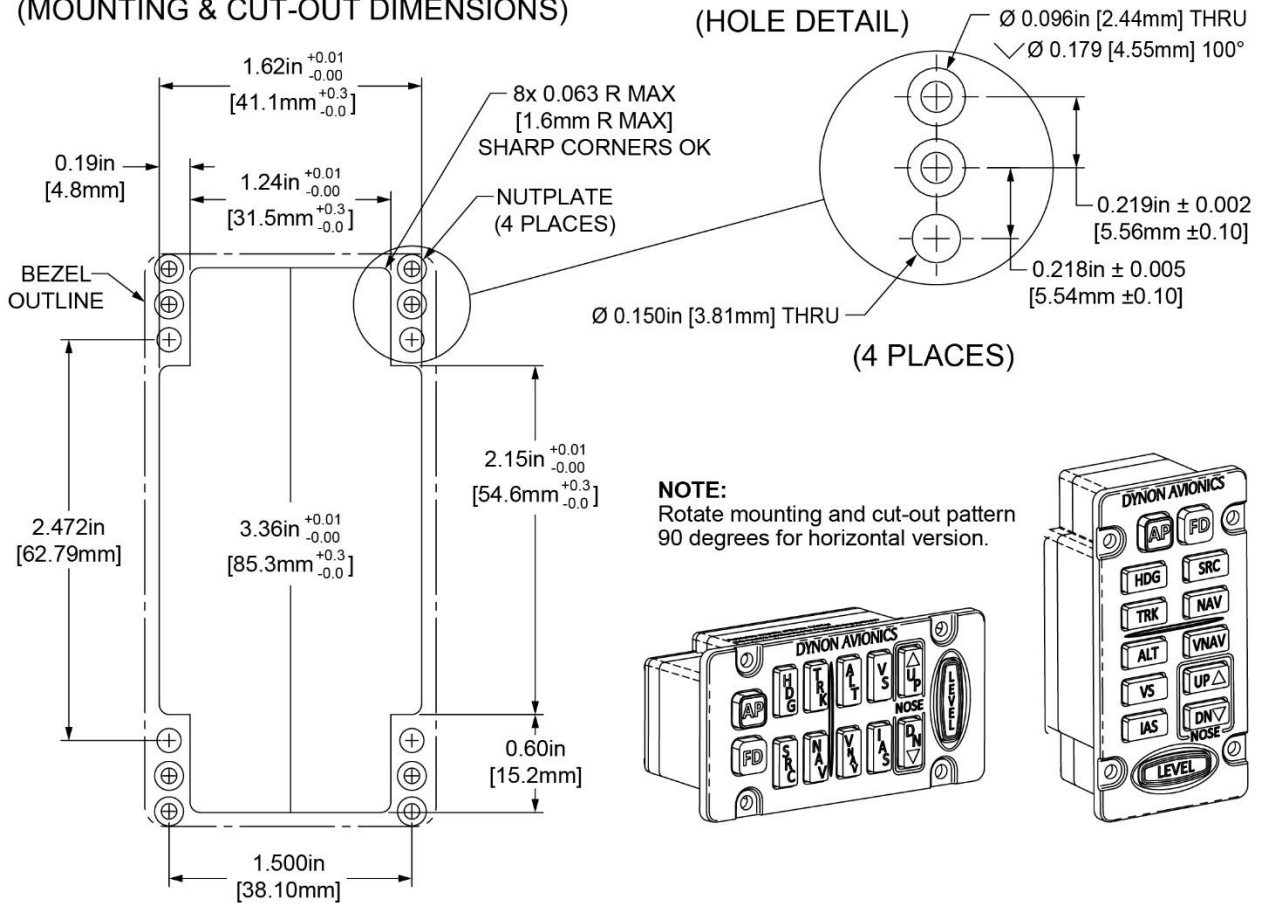

Figure 124: SV-AP-PANEL Panel Cutout and Mounting Hole Dimensions

19.2 Electrical Installation

The SV-AP-PANEL has two (2) SkyView Network connections (D9M connectors). Both connectors are electrically identical and are internally connected. Thus, the SV-AP-PANEL can be installed in the SkyView Network as a "pass-through" device, or "daisy chained" from one (1) SkyView Network device, through the SV-AP-PANEL, to the next SkyView Network device. The SV-NET-1.5CC is an 18-inch (45.72 cm) SkyView Network cable that is ideal for such situations. The SV-AP-PANEL receives power (for operation of the buttons) from SkyView Network. Dimming of the SV-AP-PANEL is controlled by the SkyView display(s).

If the installation includes an SV-AP-TRIMAMP Autopilot Trim Amplifier, installers need to create a D15F wire harness for connection to the SV-AP-TRIMAMP module and the airplane's trim buttons/switches (see Section 31.6.9: SV-AP-PANEL Pinout (D15 connector) and Section 22.2: Electrical Installation for pin and wire connections).

20 SV-BUTTON-LEVEL Autopilot Level Button

To provide a prominent LEVEL button on the panel the SV-BUTTON-LEVEL kit. Like most other Dynon Avionics panel units, the SV-BUTTON-LEVEL is backlit, and the degree of backlighting is controlled by SkyView. The SV-BUTTON-LEVEL is the same width, and similar appearance, as Dynon Avionics panel units such as SV-AP-PANEL, SV-COM-PANEL, and SV-KNOB-PANEL.

Pressing an External LEVEL Button such as the SV-BUTTON-LEVEL, the SkyView's AP LEVEL mode is engaged.

In SkyView, this is equivalent to pressing MAIN MENU > AUTOPILOT > LEVEL and the LEVEL button on the (optional) SV-AP-PANEL.



Figure 125: Level Button
SV-LEVEL-BUTTON



Figure 126: SV-BUTTON-LEVEL Kit

20.1 Mechanical Installation

The following diagram shows the mounting dimensions of the SV-BUTTON-LEVEL.

(MOUNTING & CUT-OUT DIMENSIONS)

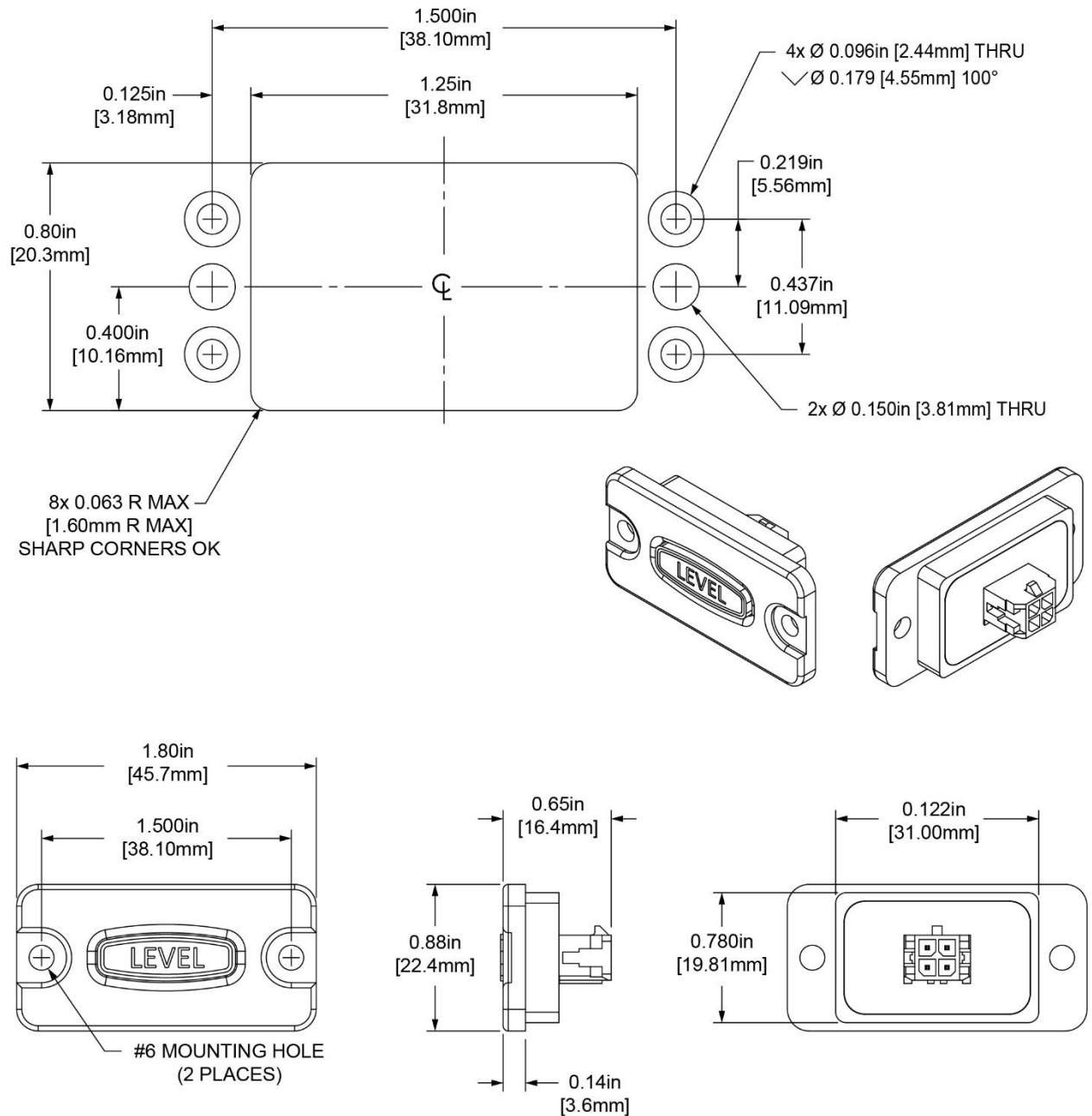

Figure 127: SV-BUTTON-LEVEL Installation Dimensions (Not to Scale)

20.2 Electrical Installation

Table 51: Connections for SV-BUTTON-LEVEL

Pin	Wire Color	Connection Points / Notes
1	Red	Aircraft Power; connect to same point as SkyView display Power (Red) wires, Pins 1 and 20.
2	White	SkyView Pin 26 – White wire 24V electrical systems require a 1.1KΩ resistor (included in the kit) in series with the SV-BUTTON-LEVEL's white wire and the SkyView display's Pin 26 white wire. If you have multiple SkyView displays, connect this wire to only one (1) display.
3	Orange / Black	SkyView Pin 28 – Orange / Black Connect wire. If you have multiple SkyView displays, see the note below – Considerations for SV-BUTTON-LEVEL.
4	Black	Aircraft Ground; connect to the same point as SkyView display Ground (Black) wires, Pins 21 and 22.

20.3 Considerations for SkyView Systems with Multiple SkyView Displays



Prior revisions of the SkyView System Installation Guide recommended that in SkyView systems with multiple displays, for redundancy the External LEVEL Button should be connected to all SkyView displays in parallel. The following recommendations supersede that earlier guidance.

Do not connect the Orange / Black wire of the SV-BUTTON-LEVEL *directly* to the Orange / Black Wire (Pin 28) of multiple SkyView displays. If you do so, when one (1) display is powered off, it will cause displays that are powered on to see the LEVEL input as being pushed (the display powered off will "ground" this input). This could cause the unintentional activation of LEVEL mode or could prevent the SV-BUTTON-LEVEL from operating.

20.4 Installation Options on Multiple SkyView Displays

Choose one (1) of these options if you have multiple SkyView displays and you want to connect SV-BUTTON-LEVEL to all displays for failover / redundancy:

- Connect the SV-BUTTON-LEVEL to only one (1) display. The SV-BUTTON-LEVEL will operate for all displays in the SkyView system if the display the SV-BUTTON-LEVEL is wired to is powered on and operating normally. As a non-flight-critical function, the loss of the SV-BUTTON-LEVEL in some display failures may be acceptable for your installation.
 - In SkyView, use of the LEVEL function via the soft keys via any operating SkyView display is still possible, as well as pushing the LEVEL button on the (optional) SV-AP-PANEL.
- Install a diode for each individual display's connection to the SV-BUTTON-LEVEL (not included in the SV-BUTTON-LEVEL kit). The diode should be installed with

the cathode end (painted band on the diode) oriented towards the SV-BUTTON-LEVEL and should be installed in-line with the contact wire between the SkyView display and the SV-BUTTON-LEVEL. One (1) diode is needed per button, per display. Any diode will work for this application. An example diode is the very common 1N914, available from Radio Shack (P/N 276-1122). With a diode installed for each display, the SV-BUTTON-LEVEL will work correctly with any combination of displays powered on and powered off.

20.5 Troubleshooting

During bootup, SkyView checks the status of the External LEVEL Button input (SV-BUTTON-LEVEL). If SkyView detects that the External LEVEL Button is pressed (the input is grounded) during bootup, the External LEVEL Button is assumed to be stuck (or incorrectly installed), resulting in:

- A Message is displayed: EXT LEVEL BUTTON STUCK.
- The External LEVEL Button input is ignored for the remainder of the time SkyView is operational (will be checked again at next bootup).



Figure 128: EXT LEVEL BUTTON STUCK Message

21 Autopilot Disconnect Button

The primary purpose of the Autopilot Disconnect button (AP DISC) is to immediately disengage the Autopilot.



Installation of an Autopilot Disconnect button is required.



If Autopilot installation includes an SV-AP-TRIMAMP Trim Motor Adapter, the Autopilot Disconnect switch should be installed on the yoke/wheel grip.



Yoke/wheel grip-mounted Autopilot Disconnect buttons should be installed on the opposite side of the yoke/wheel from the throttle control.

21.1 Yoke-mounted Button

This button should be a red single pole, normally open, momentary button with a positive click when closed. Verify that two (2) terminals of the button are shorted when the button is pressed and open (no-connect) when the button is released. One (1) terminal of the button should connect to the servos' yellow wires, and the other should connect to ground.

A 4.7 - 5.3k ohm resistor across the yoke-mounted AP DISC is required. This allows SkyView to detect a break in this circuitry and alert the pilot if this resistor is present in the installation. Set SETUP MENU > AUTOPILOT SETUP > DISENGAGE BUTTON > ENABLE BROKEN LINE DETECT to "YES."

During bootup, SkyView checks the status of the A/P DISC button. If SkyView detects that the button is pressed (the input is grounded) during bootup, the A/P DISC button is assumed to be stuck (or incorrectly installed), resulting in:

1. A CAUTION message is displayed: AP DISCONNECT STUCK, and
2. The Autopilot (AP) cannot be engaged for the remainder of the time SkyView is operational (the system will be checked again at next bootup).

21.2 Panel-mounted Button

The SV-BUTTON-APDISC Autopilot Disconnect button can be installed in the instrument panel and wired to SkyView.

This button is backlit, and the degree of backlighting is controlled by SkyView. It is the same width, and similar appearance, as Dynon Avionics panel units such as SV-AP-PANEL, SV-COM-PANEL, SV-KNOB-PANEL.

The Autopilot Disconnect button will disengage the autopilot when depressed.

21.2.1 Mechanical Installation

The following diagram shows the mounting dimensions of the SV-BUTTON-APDISC.

(MOUNTING & CUT-OUT DIMENSIONS)

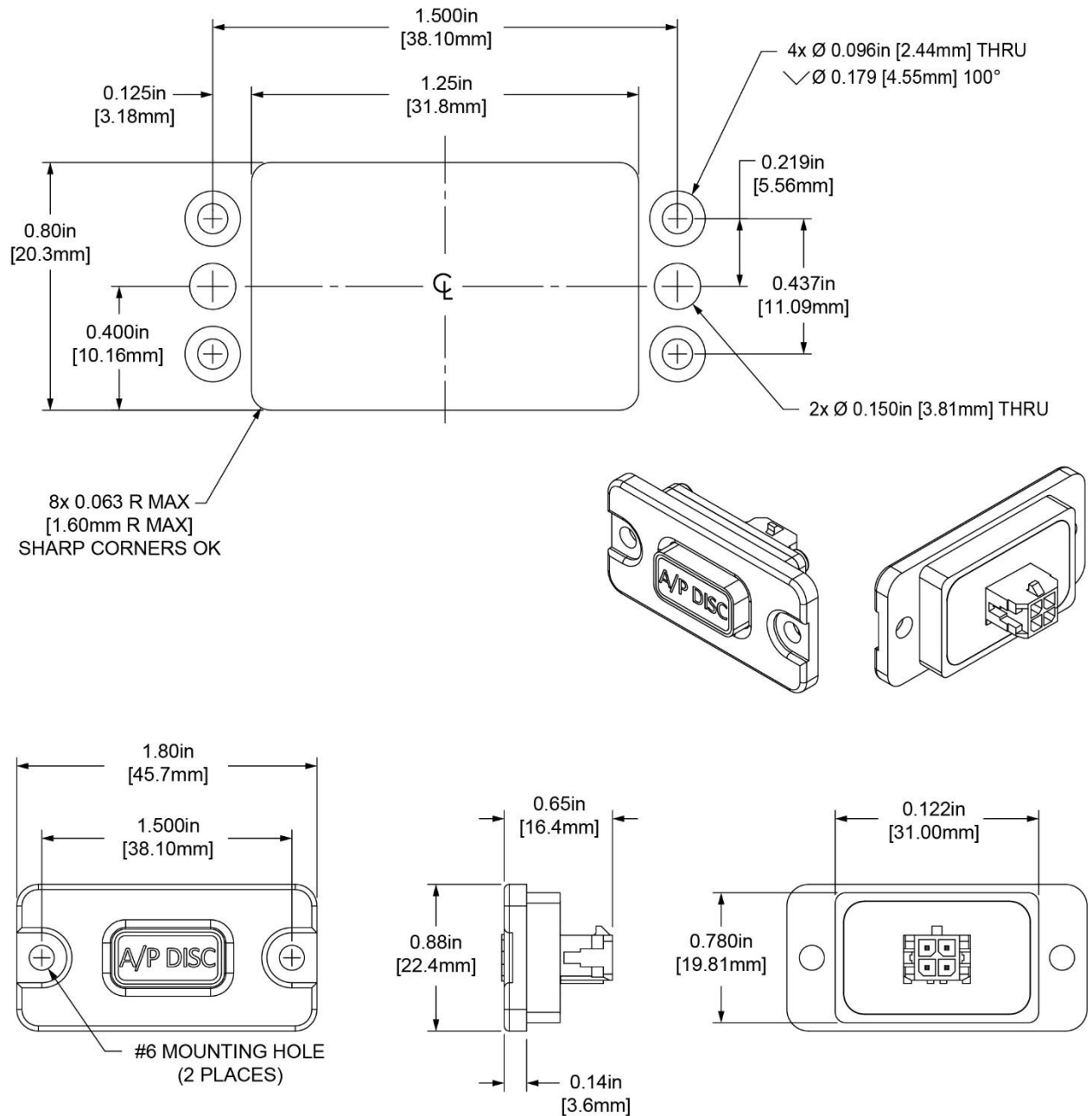

Figure 129: SV-BUTTON-APDISC Mounting Dimensions (Not to Scale)

21.2.1.1 Electrical Installation

Table 52: Connections for SV-BUTTON-APDISC

Pin	Wire Color	Connection Points / Notes
1	Red	Aircraft Power; connect to same point as SkyView display Power (Red) wires, Pins 1 and 20.
2	White	SkyView Pin 26 – White wire If you have multiple SkyView displays, connect this wire to only one (1) display.
3	Yellow	Servo Disengage (D9M Connector Pin 3)
4	Black	Aircraft Ground; connect to the same point as SkyView display Ground (Black) wires, Pins 21 and 22.

22 SV-AP-TRIMAMP Trim Motor Adapter

The SV-AP-TRIMAMP Trim Motor Adapter allows the SkyView HDX Autopilot system to interface with factory-installed or certified trim systems (see Dynon's Approved Model List (AML) at dynoncertified.com/docs for applicable aircraft).

22.1 Mechanical Installation

The following is a list of guidelines for installing the SV-AP-TRIMAMP:

- Mounting orientation is not critical. Unit can be mounted horizontally or vertically.
- Mounting location should have adequate space for module, electrical connections, and servicing (see Figure 130 for mounting dimensions).
- Mounting location should not be close to any sources of high heat. Unit is not a significant heat source and does not need to be kept away from other devices for this reason.
- Avoid mounting locations that are subject to severe vibration and extreme humidity.
- Consider locating the SV-AP-TRIMAMP so the original wiring from the instrument panel to the trim motor can be reused.
- *DO NOT* mount unit on engine side of the firewall.
- *DO NOT* rivet unit directly to airplane structure, as this will hinder future removal if necessary.



Mounting hardware is not included with the SV-AP-TRIMAMP. Use AN/MS aviation standard screws and locknuts or nutplates to mount the SV-AP-TRIMAMP.

To mount the SV-AP-TRIMAMP to the airplane's structure:

1. Select mounting location (see guidelines listed above).
2. Use Figure 130 and mounting holes on unit as template to mark hole locations on airplane structure.
3. Drill and deburr holes for fasteners.
4. Secure unit to airplane structure with AN/MS aviation standard hardware.

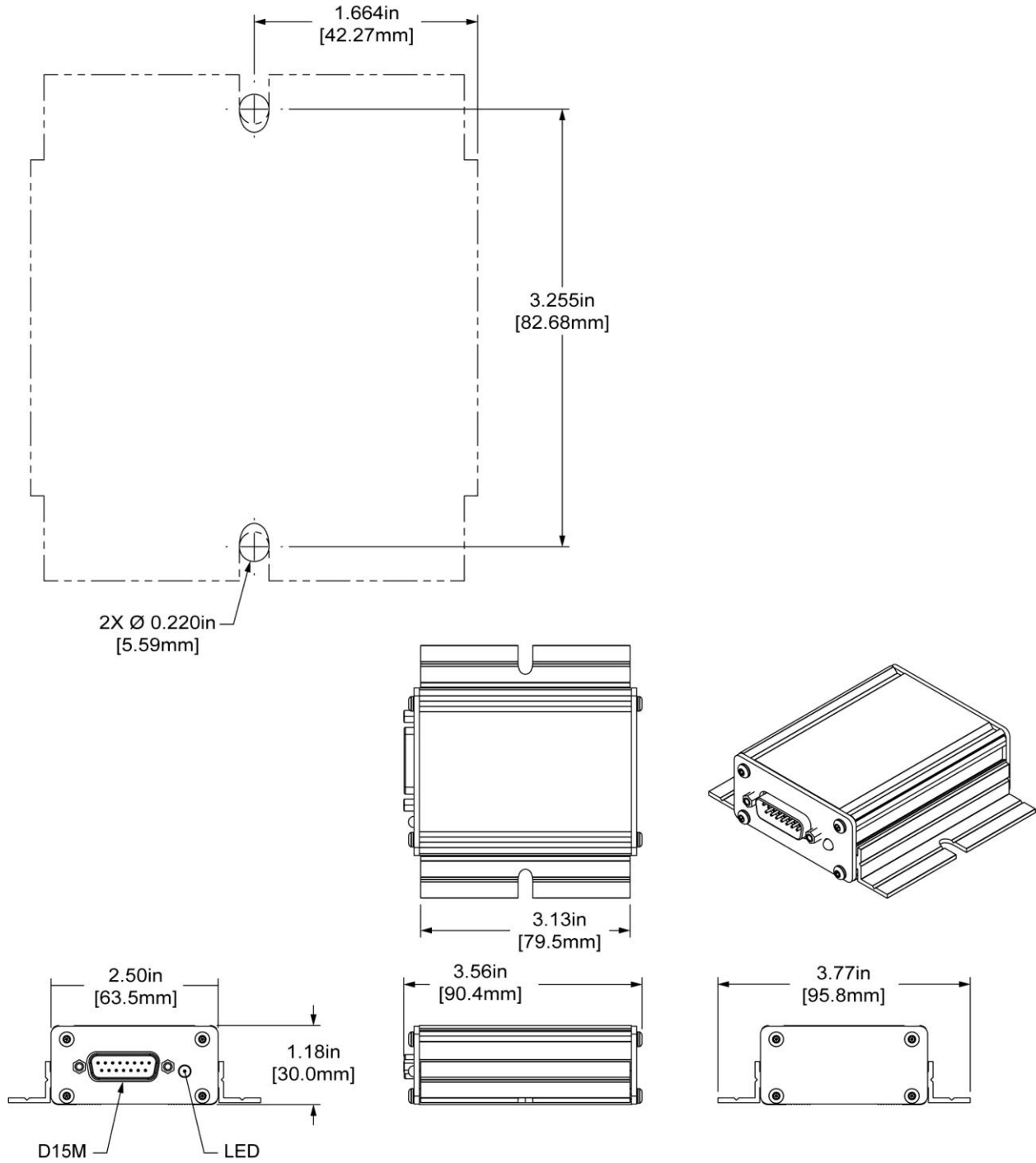

Figure 130: SV-AP-TRIMAMP Installation Dimensions

22.2 Electrical Installation

To connect an SV-AP-TRIMAMP, installers need to create a D15F wire harness (see Table 53 for pin/wire connections). Installers also need to create a D15F wire harness for the SV-AP-PANEL control panel (see Section 31.6.9: SV-AP-PANEL Pinout (D15 connector)). 20 AWG wire is recommended for power and ground wires; 22 AWG wire is recommended for all other connections.

Table 53: SV-AP-TRIMAMP, Pin/Wire Connections

D15 Pin #	D15 Wire Function	D15 Wire Color	Connection / Notes
1	N/A	No Wire	No Connection
2	Trim - Activity	Installer Determined	Pin 14 on Display D37 Connector
3	Trim Motor - In B	Installer Determined	Pin 8 on SV-AP-PANEL D15 Connector
4	Trim Motor - In A	Installer Determined	Pin 7 on SV-AP-PANEL D15 Connector
5	Ground	Installer Determined (use Black)	Pin 2 on SV-AP-PANEL D15 Connector
6	Trim - Interrupt	Installer Determined	AP Disconnect Button
7	Ground	No Wire	No Connection
8	Ground	Installer Determined (use Black)	Common Airframe Ground, or: Pin 21, 22 on Display D37 Connector
9	Trim Motor -Clutch Ground	Installer Determined	Ground Terminal on Trim Motor Clutch
10	Trim Motor - Clutch	Installer Determined	Positive Terminal on Trim Motor Clutch
11	Trim Motor - B	Installer Determined	Either Terminal on Trim Motor
12	Trim Motor - A	Installer Determined	Either Terminal on Trim Motor
13	Power	Installer Determined (use Red)	Pin 9 on SV-AP-PANEL D15 Connector
14	Power	No Wire	No Connection
15	Power	Installer Determined (use Red)	Electrical Bus, 5A Breaker/Fuse

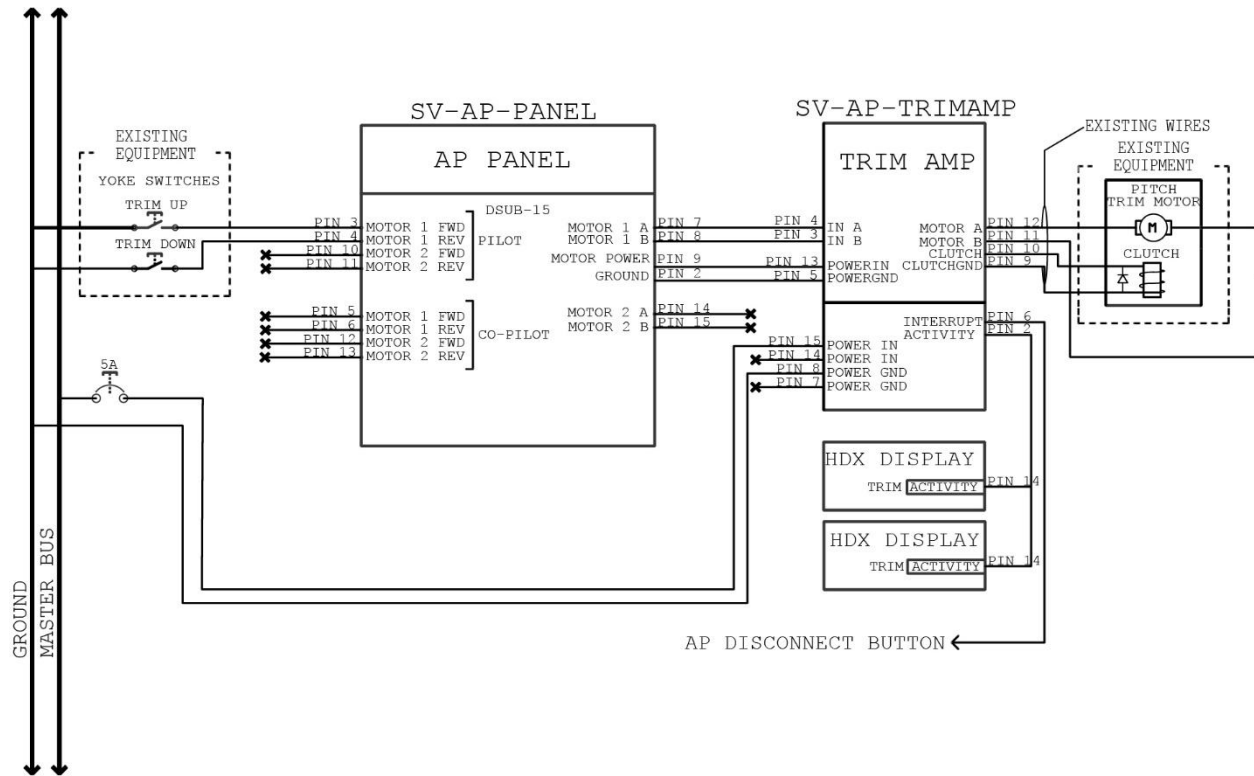

Figure 131: SV-AP-TRIMAMP Electrical Installation

22.2.1 SV-AP-TRIMAMP Wire Harness

The SV-AP-TRIMAMP is connected to the airplane's electrical system, the airplane's trim motor, the Autopilot Disconnect button, and SkyView HDX display units using a fabricated D15F wire harness. The SV-AP-TRIMAMP is also connected to the SV-AP-PANEL (see Section 19: SV-AP-PANEL Autopilot Control Panel).

The SV-AP-TRIMAMP requires a power supply of 10–30V DC, and power input must be protected with an aviation-grade 5A circuit breaker. See Section 30.11: SV-AP-TRIMAMP Specifications for specific motor and clutch requirements.



The Trim system must include a switch labeled TRIM POWER that can remove power from all electric trim motors.



The TRIM POWER switch must be in a prominent position that is easy for the pilot to find and reach in the event of an Autopilot malfunction.



The Autopilot Disconnect switch should be installed on the yoke/wheel grip. (See Section 21 for more information.)



Yoke/wheel grip-mounted Autopilot Disconnect buttons should be installed on the opposite side of the yoke/wheel from the throttle control. (See Section 21 for more information.)

The ground connection needs to be common with all devices that interface with the SkyView HDX system.

To connect the SV-AP-TRIMAMP wire harness:

1. Make sure airplane power is disconnected.
2. If needed, connect a dedicated 5A circuit breaker to appropriate electrical bus (see airplane manufacturer's documentation for guidance).
3. Route SV-AP-TRIMAMP harness as follows (also see Figure 131):
 - *Power In* wire (pin 15) to power supply circuit breaker.
 - *Ground* wire (pin 8) to common airframe ground.
 - *Interrupt* wire (pin 6) to Autopilot Disconnect button.
 - *Activity* wire (pin 2) to all SkyView HDX display units (splice wire as needed).
 - *Motor A* wire (pin 12) to Pitch Trim Motor.
 - *Motor B* wire (pin 11) to Pitch Trim Motor.
 - *Clutch* wire (pin 10) to Pitch Trim Motor Clutch (if equipped).
 - *Clutch Gnd* wire (pin 9) to Pitch Trim Motor Clutch (if equipped).

4. Support and secure wires to avoid high heat and entanglement with moving components.
5. Use insulated connectors to connect SV-AP-TRIMAMP harness as follows (also see Figure 131):
 - *Power In* wire (pin 15) to power supply circuit breaker terminal.
 - *Ground* wire (pin 8) to common airframe ground terminal.
 - *Interrupt* wire (pin 6) to Autopilot Disconnect button terminal.
 - *Activity* wire (pin 2) to Trim Activity (pin 14) on all SkyView HDX display unit harnesses.
 - *Motor A* wire (pin 12) to one terminal on Pitch Trim Motor.
 - *Motor B* wire (pin 11) to the other terminal on Pitch Trim Motor.
 - *Clutch* wire (pin 10) to positive terminal on Pitch Trim Motor Clutch (see airplane manufacturer's documentation for guidance).
 - *Clutch Gnd* wire (pin 9) to ground terminal on Pitch Trim Motor Clutch (see airplane manufacturer's documentation for guidance).



The SV-AP-TRIMAMP is designed to work with Trim Motors with and without a clutch.

22.2.2 SV-AP-PANEL Wire Harness

The SV-AP-PANEL is connected to the SV-AP-TRIMAMP and the airplane's trim buttons/switches using a fabricated D15F wire harness (see Section 31.6.9: SV-AP-PANEL Pinout (D15 connector)).

To connect the SV-AP-PANEL's wire harness:

1. Make sure airplane power is disconnected.
2. Plug D15F wire harness into matching D15M connector on SV-AP-PANEL.
3. Route SV-AP-PANEL harness as follows:
 - *Motor Power* wire (pin 9) to SV-AP-TRIMAMP.
 - *Ground* wire (pin 2) to SV-AP-TRIMAMP.
 - *Motor 1 A* wire (pin 7) to SV-AP-TRIMAMP.
 - *Motor 1 B* wire (pin 8) to SV-AP-TRIMAMP.
 - *Motor 1 Fwd* wire (pin 3) to Trim Up button/switch.
 - *Motor 1 Rev* wire (pin 4) to Trim Up button/switch.

4. Support and secure wires to avoid high heat and entanglement with moving components.
5. Use insulated connectors to connect SV-AP-PANEL harness as follows:
 - *Motor Power* wire (pin 9) to *Power In* wire (pin 5) on SV-AP-TRIMAMP harness.
 - *Ground* wire (pin 2) to *Power Ground* wire (pin 13) on SV-AP-TRIMAMP harness.
 - *Motor 1 A* wire (pin 7) to *In A* wire (pin 4) wire on SV-AP-TRIMAMP harness.
 - *Motor 1 B* wire (pin 8) to *In A* wire (pin 3) wire on SV-AP-TRIMAMP harness.
 - *Motor 1 Fwd* wire (pin 3) to Trim Up button/switch terminal.
 - *Motor 1 Rev* wire (pin 4) to Trim Down button/switch terminal.

22.3 Configuration

After the entire Autopilot system has been installed, installers need to configure and test the Trim system. This involves performing a trim motor calibration, configuring Auto-Trim settings, and then testing Auto-Trim in flight.



The following configuration procedures assume the SV-AP-TRIMAMP, SV-AP-PANEL, and trim motor have been electrically connected as detailed in Section 22.2. This ensures that MOTOR 1 in the TRIM MOTOR CONFIGURATION menu is associated with the Pitch Trim Motor in the airplane.

To calibrate SkyView HDX for the airplane's trim motor:

1. Make sure all trim tabs on airplane are centered.
2. Press and hold Button #7 and #8 simultaneously to enter SETUP MENU.
3. Navigate to HARDWARE CALIBRATION > TRIM MOTOR CONFIGURATION > MOTOR 1 > AUTO-TRIM FUNCTION, and then push START.
4. Follow on-screen instructions. When complete, trim for pitch axis is enabled.
5. Press BACK or EXIT.

To configure Auto-Trim for airplane:

1. Press and hold Button #7 and #8 simultaneously to enter SETUP MENU.
2. Navigate to HARDWARE CALIBRATION > TRIM MOTOR CONFIGURATION > MOTOR 1.
3. Set and/or confirm following configuration parameters:
 - QUICKEST TRIM SPEED > TRIM MOTOR SPEED = 100%
 - QUICKEST TRIM SPEED > AT AND BELOW AIRSPEED = (keep default)

- SLOWEST TRIM SPEED > TRIM MOTOR SPEED = 100%
- SLOWEST TRIM SPEED > AT AND ABOVE AIRSPEED = (keep default)
- TRIM MOTOR PULSE RATE = 4

4. Press BACK or EXIT.



Fine-tuning the responsiveness of Auto-Trim involves adjusting the TRIM MOTOR PULSE RATE parameter. For more information, see the *SkyView HDX General Maintenance Manual* document.

23 Angle of Attack Probe

Dynon offers an Angle of Attack (AoA) probe that is two probes in one. It has an AoA line for AoA measurement and a pitot line for IAS measurement. In certified installations, only the AoA line is used. Both lines are labelled for identification. For simplification, this document refers to the probe as an AoA probe only.

Dynon Avionics does not provide mounting hardware for installing an AoA probe because installations vary from airplane to airplane. An AoA system installation is subject to approval of the Authorized Inspector prior to returning the airplane to service.



For certification and to ensure airworthiness, an AoA system must be installed and configured following the instructions in this section.



The pitot line in the AoA probe must be plugged and remain unconnected in certified installations.

23.1 Mechanical Installation

The Dynon Avionics AoA probe is generic, allowing it to be installed in any aircraft, providing the correct methods and materials are used. Follow the guidance below when installing an AoA probe and plumbing:

- Probe:
 - The Dynon AoA probe will fit in a standard pitot mast.
 - Use the same mast (same part number) for installing the AoA probe as the manufacturer used to install the pitot sensor.
 - Mount the mast for the AoA probe to the airplane using the same methods as manufacturer used to install the mast for pitot sensor.
 - Locate the AoA mast and probe in a similar position as the pitot mast and sensor:
 - outside of propeller blast (usually mounted to underside of wing on single-engine airplanes and to fuselage on twin-engine airplanes),
 - in free-flowing air, not behind obstructions such as a wing strut,
 - at same distance from the leading edge of the wing as the pitot mast,
 - at same distance below the wing as the pitot mast,
 - at same angle to underside of the wing as the pitot mast,
 - in area with adequate internal access for installation of mast and sensor.
 - The Dynon AoA probe is not certified for use as a pitot sensor.

- Plumbing:
 - The plumbing of pneumatic systems, such as an AoA system, typically utilize thin-walled seamless aluminum tubing, combined with flexible rubber and/or neoprene tubes around the instruments to facilitate easy removal.
 - If in doubt about the correct material to use, utilize the same materials and methods used by the airplane manufacturer for similar systems such as pitot and static. The most reliable source of information on the material used in a particular airplane is the manufacturer’s maintenance manual. If that source is not available, AC 43.13-1B, Chapter 8 provides inspection and maintenance guidance on fuel lines, while Chapter 9 provides the same level of information on hydraulic systems.
 - When installing metal tubing and/or flexible hoses, do so in accordance with guidance in AC 43.13-1B, Chapter 9. Aircraft Systems and Components; Section 2. Hydraulic Systems 9-30, Hydraulic Lines and Fittings.
 - Make sure the pitot line in the AoA probe is plugged. Do not connect the pitot line to any instrument or SkyView component.

23.2 AoA System Configuration

To properly configure the Angle of Attack system, enter the SETUP MENU > PFD SETUP > ANGLE OF ATTACK menu, and then select AUDIO ONLY, as shown in Figure 132.

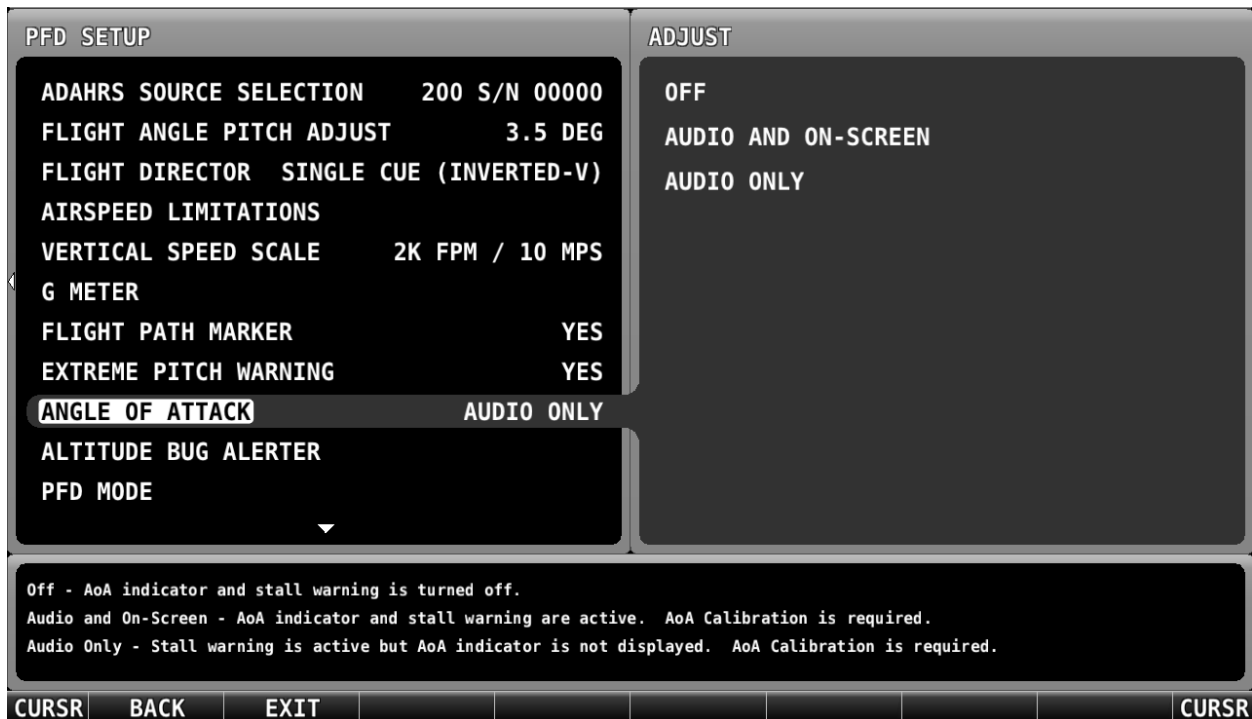

Figure 132: Angle of Attack System Configuration

24 SV-NET-HUB

The SV-NET-HUB is designed to ease component connection to the SkyView HDX Network. It is an optional component for SkyView HDX Systems.

24.1 Mechanical Installation

The following is a list of guidelines for mounting an SV-NET-HUB:

- Mounting orientation is not critical—it can be mounted horizontally or vertically.
- Mounting location should have adequate space for unit, electrical connections, and servicing (see Figure 133 for mounting dimensions).
- Avoid locations that are subject to severe vibration and extreme humidity.
- Mounting location should not be close to any sources of extreme heat.
- *DO NOT mount unit on engine side of the firewall.*
- *DO NOT rivet unit directly to airplane structure, as this will hinder future removal if necessary.*



Mounting hardware is not included with the SV-NET-HUB. Use #4 or #6 screws and locknuts or nutplates to mount the SV-NET-HUB. Fasteners must be AN/MS aviation standard hardware.

To mount the SV-NET-HUB to an airplane's structure:

1. Select mounting location (see guidelines listed above).
2. Use Figure 133 and mounting holes on unit as template to mark hole locations on airplane structure.
3. Drill and deburr holes for fasteners (see Figure 133 for hole size).
4. Secure unit to airplane structure using #4 or #6 fasteners.

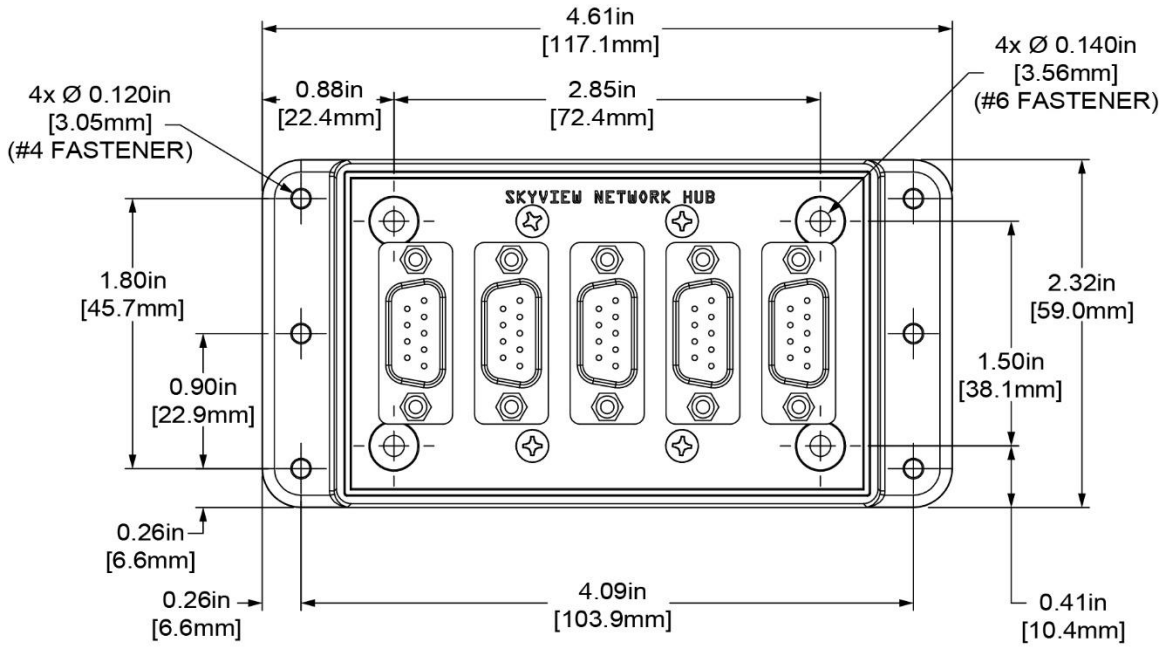

(MOUNTING DIMENSIONS)

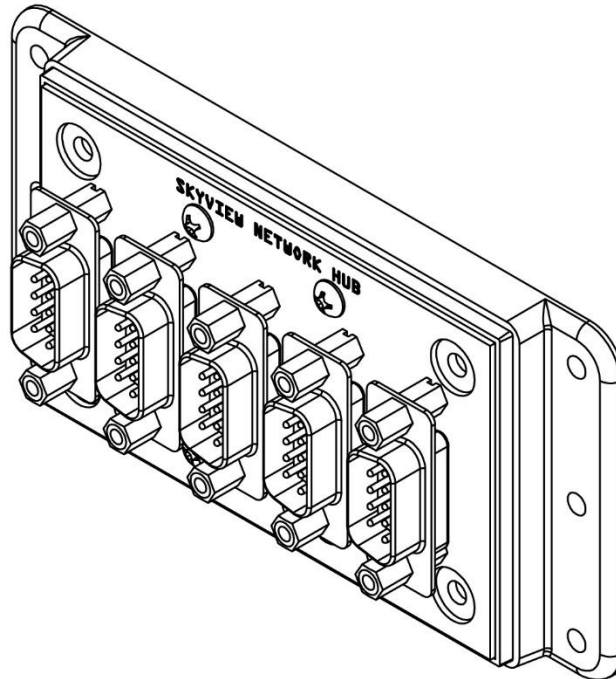
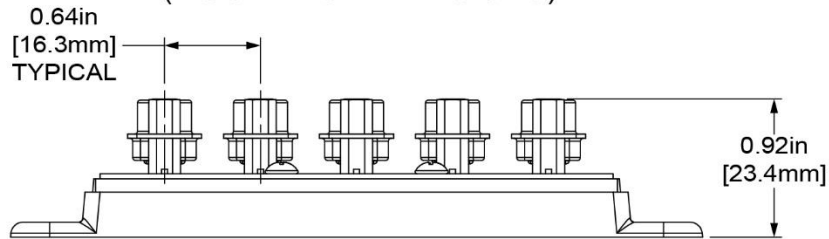

Figure 133: SV-NET-HUB, Mounting Dimensions

24.2 Electrical Installation

The SV-NET-HUB has five D9M network connectors. The connectors are identical and internally connected, providing a hub for network devices to connect to the SkyView HDX Network. Connect the SV-NET-HUB network hub to the SkyView HDX Network with a D9F network cable.

25 Panel-Mount USB Port

The Panel-Mount USB Port extends a SkyView HDX display's USB port to the instrument panel. USB ports are used for transferring files to and from a SkyView HDX display. The Panel-Mount USB Port is available in three cable lengths (12", 24", 36"). It is an optional component for a SkyView HDX System.

25.1 Mechanical Installation

The Panel-Mount USB Port mounts directly to the instrument panel. Before installing the Panel-Mount USB Port, read and understand the information in Section 4: Instrument Panel Design.



Mounting hardware is not included with the Panel-Mount USB Port. Use #4 screws and locknuts to mount the port.

To mount the Panel-Mount USB Port to an instrument panel:

1. Use Figure 134 as a guide to prepare instrument panel for cutting.
2. Cut an opening for unit in instrument panel. Make sure instrument panel opening includes necessary margins for paint or other applied finishes.
3. Drill (#30) and deburr holes for fasteners.
4. Secure unit to instrument panel with #4 fasteners.

(MOUNTING & CUT-OUT DIMENSIONS)

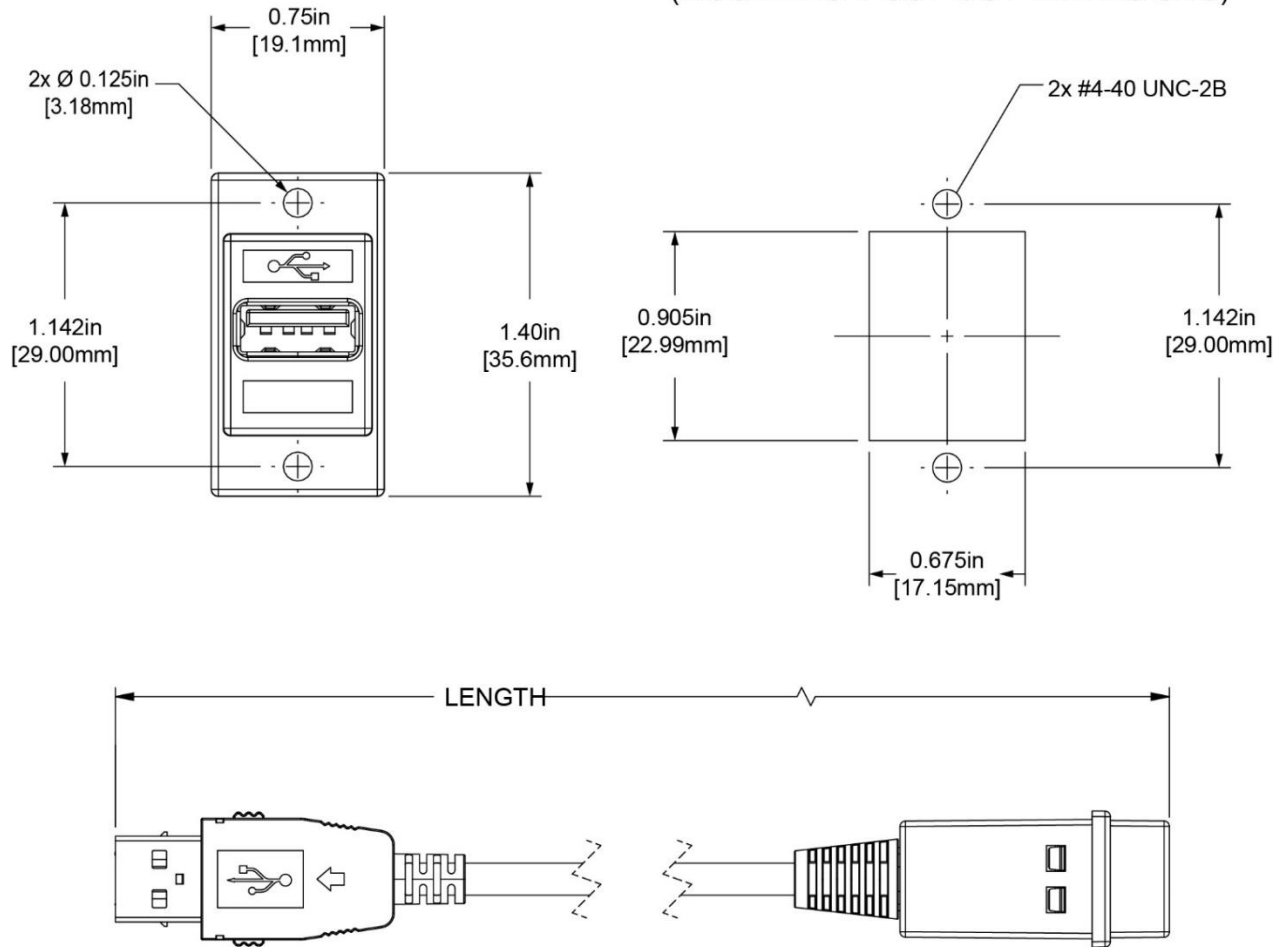

LENGTH		WEIGHT
INCHES	MM	LBS
12.0	[304.8]	.05
24.0	[609.6]	.10
36.0	[914.4]	.15

Figure 134: Panel-Mount USB Port, Mounting Dimensions

25.2 Electrical Installation

Connect the Panel-Mount USB Port cable to one of two USB ports on the rear of a SkyView HDX display unit.

26 Standby Flight Display

See the *EFIS-D10A Installation and Maintenance Manual* document or the *D30 Installation and Maintenance Manual* document.

27 Display Operation

After reading this section, you should be familiar with basic SkyView display operation including how to use knobs and buttons, how to turn displays on and off, how to access and navigate menus, how to configure the SkyView network, and how to perform Software updates and other file operations.



The SkyView SV-HDX800 and SV-HDX1100 displays are identical in functionality and presentation. The only difference is in the size of the screen.

27.1 Function Control

Although operation of the primary functions of the SkyView HDX system is intuitive, it does require a reasonable degree of familiarity to utilize all its functions without compromising attention to other flying tasks. Users are encouraged to read the *SkyView Pilot's User Guide* thoroughly before flight and to take advantage of the training videos available on [youtube.com/DynonAvionics](https://www.youtube.com/DynonAvionics).

27.1.1 Knobs and Buttons

Knobs and buttons are used for various functions including powering the unit on and off, entering and navigating menus, and adjusting values.

Knobs are located on the left and right sides of the display. They can be rotated both directions and pushed. The current knob function is indicated by the "soft" label above the knob. Knob function is contextual and can change when the contents of the screen are changed by the pilot (see Figure 135).

Eight buttons are located across the bottom of each display. The area immediately above the buttons is the Main Menu, which shows "soft" labels that identify the function of each button. Buttons have different functions depending on the information being shown on the display. The labels for each button on the Main Menu will change accordingly (see Figure 135).



Figure 135: SkyView HDX Display Front Bezel Layout

SkyView HDX knobs do not move (click) up, down, left, or right – they only rotate clockwise and counter-clockwise. SkyView HDX knobs incorporate a pushbutton function.

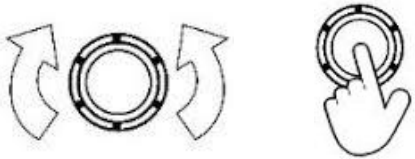

Figure 136: SkyView HDX Knob Rotation and Pushbutton Action

A keypad button has a function if there is a label above it. If there is no label, there is no function. The figure below shows an example button label.

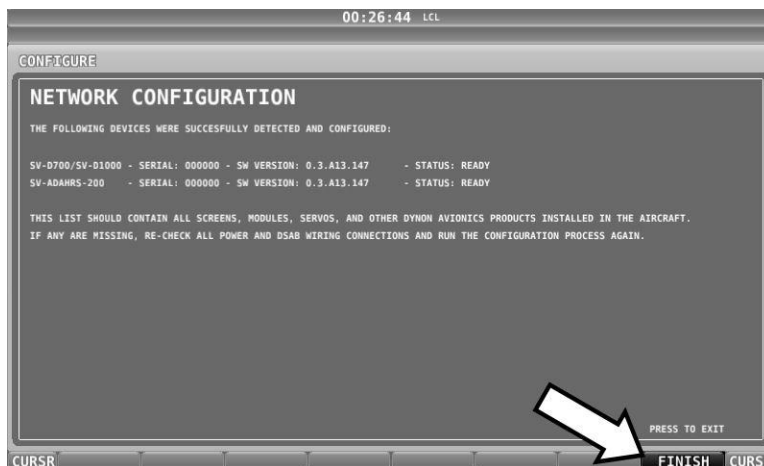

Figure 137: Example Button Label

When you press a button, its label is highlighted. When you let go, that button's action is invoked.



Button labels are called out in all capital letters such as BACK, EXIT, FINISH, and CLEAR. This manual directs users to press a button by using its label. For example, when this manual asks you to press FINISH, it is asking you to press the button with the FINISH label above it.

When a parameter needs to be adjusted, the SkyView HDX's knob / button is used to change the parameter. When setting values with the knob, each character (symbol, letter or digit) must be selected and adjusted successively.

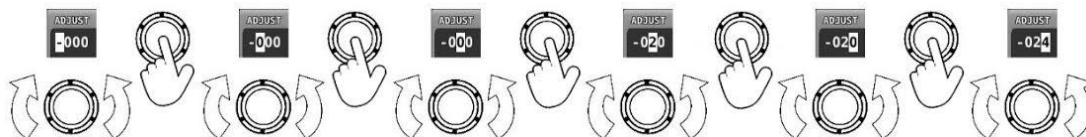

Figure 138: Adjusting Successive Characters in SkyView HDX

When the parameter is first displayed, the most significant (left-most) field is highlighted. Rotate the knob clockwise to increment the parameter, or counter-clockwise to decrement the parameter. In this example, the first time you rotate the knob, you toggle between the "-" and "+" symbols.

After changing the parameter to the desired value, push the knob (pushbutton) to accept the desired value. The cursor will automatically change to the next field (to the right). Once you have adjusted the value appropriately (finished entering the desired data), pushing the knob will generally accept the entire value and return to the menu. Occasionally, it is necessary to press ACCEPT button (on the keypad).

When in a list of menu items, to move up and down the menu, simply rotate the knob *clockwise* to move *down* the menu, and *counter-clockwise* to move *up* the menu. When the desired menu is highlighted, push the knob (pushbutton) to enter the desired menu.

27.1.2 Touch Controls

SkyView HDX displays contain touchscreen functionality. Touching various items on the display allows for the item to be selected and the value adjusted. For example, touching the HSI data source allows for alternate sources to be selected.

Pilot-selectable choices for the layout of each screen can be selected by pressing DISPLAY button on Main Menu. This allows the pilot to choose whether a display should show PFD, Map, or Engine information, or some combination thereof.

See [Figure 139](#) for details for the touchable screen areas of main flight functions. Additionally, the Timer function has touchscreen control, and if a compatible NAV device is connected, the Course (CRS) functions as well.

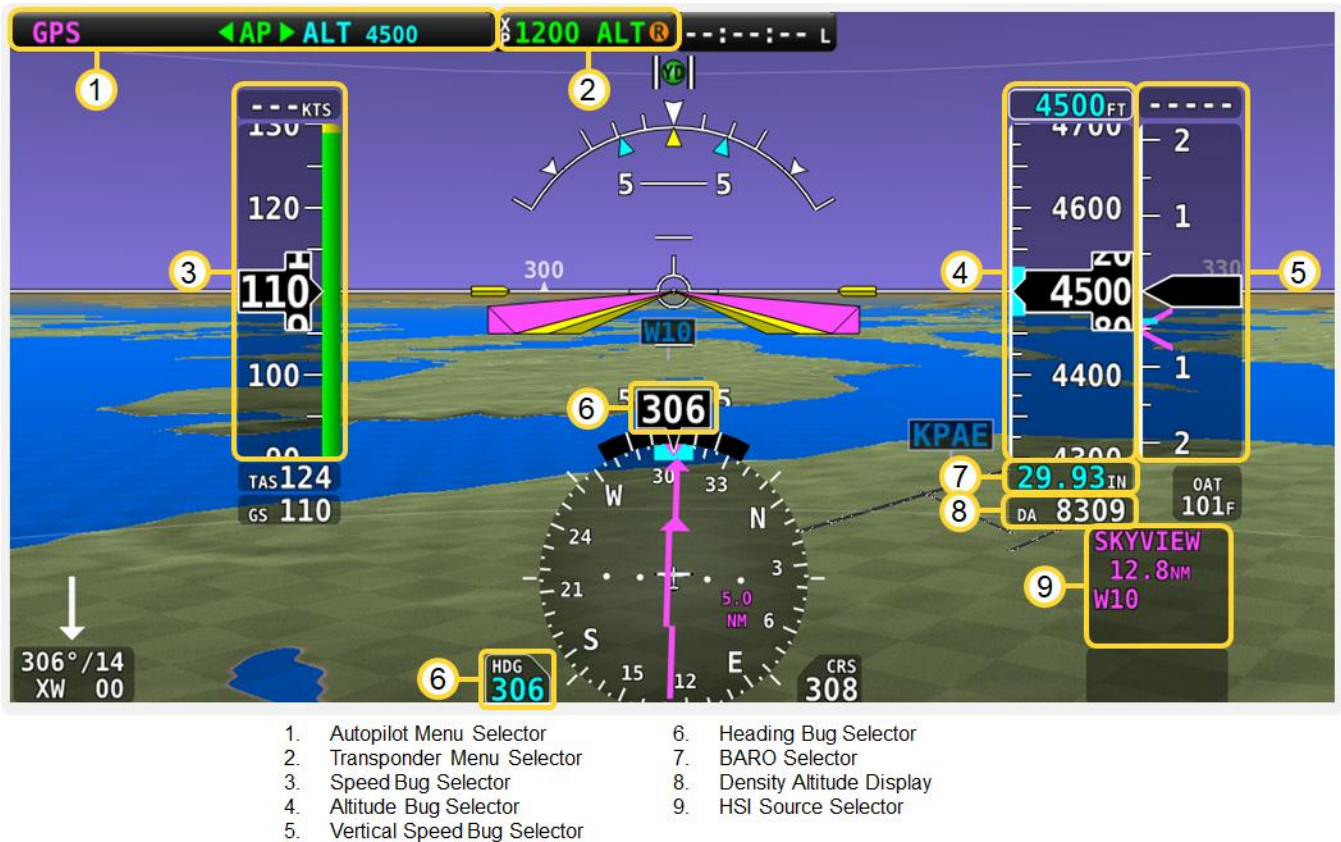

Figure 139: HDX Touch Controls

27.1.3 Menu Navigation

After the display turns on, you will see a screen like the screen below. This manual refers to the label bar at the bottom of the screen as the *Main Menu*.

Throughout this manual, the ">" character is used to indicate a sequence of menu selections or other actions you would take as you navigate the menu system. Menu selections which are followed by "..." indicate full-screen wizard interfaces which manual you through the appropriate steps. These wizard interfaces are not described in detail in this manual, as the on-screen instructions provide adequate information.

SkyView menus follow this structure: SETUP MENU > MENU > ... > MENU > PAGE or WIZARD. The setup menus (In Flight Setup or Setup) are the root of most menu navigation. Each nested menu is more specific than the previous one (1) and there is no set limit for the number of nested menus before reaching a page. A page or wizard is at the end of the chain, and it is where the user can perform a specific action such as change a specific setting, configure a SkyView network, or set up the layout of the onscreen engine gauges. Wizards employ easy-to-follow onscreen instructions.

For example, SETUP MENU > SYSTEM SETUP > MEASUREMENT UNITS > BAROMETER indicates entering the SETUP MENU, then selecting SYSTEM SETUP, then selecting MEASUREMENT UNITS, and then entering the BAROMETER Menu to select INHG, MBAR, or MMHG.

Table 54: Menu Navigation Summary

Desired Menu Action	User Action
Enter the Setup Menu	Simultaneously press and hold buttons 7 and 8 (if airspeed is greater than zero (0), you will enter the In Flight Setup Menu)
Scroll through different menus	Rotate knob
Enter menu	SkyView HDX: Push the knob (pushbutton)
Return to previous menu	Press BACK (saves settings) OR Press CANCEL (does not save settings)
Save adjusted value	Press ACCEPT
Reset adjustable value	Press DEFAULT
Save settings and return to Main Menu	Press EXIT

27.2 Screen Synchronization

SkyView HDX is designed to operate as an integrated system. SkyView configurations with more than one (1) display automatically share and synchronize settings on all displays. In-flight settings such as Baro and bugs are synchronized in real time as they are adjusted. Setup menu items are synchronized when the user exits the setup menu and also at boot up. Aviation and obstacle databases are synchronized when they are loaded on any screen if Ethernet is connected.

It is not possible to have displays on the same network that do not share configurations, settings, and real-time items. Even if a unit is off when settings are adjusted, they will be synchronized when they boot up.



For displays to properly synchronize settings their tail numbers must be the same and SkyView Network must be configured correctly. See Sections 6.3 and 6.4 for information about these required setup steps.

Only one (1) setup menu in the network may be open at once. If you try to open a setup menu on a display while it is open on another display, you will see OTHER SCREEN IN SETUP on the screen and thus cannot open the setup menu. There is no "master" in the system; changes made on any screen in the system will be automatically reflected on all other screens.

Some things are purposefully not synchronized on displays: Software, sensor configuration files (.sfg), and local display settings. You must ensure that each display is running the appropriate Software, up-to-date databases, and sensor configuration file. All of these files are available for download at dynoncertified.com/download. Also ensure that each display's local settings are appropriately configured.

27.3 Display Operation Procedures

This subsection covers basic operation procedures for displays. Detailed instructions for various menus and individual menu items are described later in this manual.

27.3.1 How to Turn the System On or Off

Table 55: Toggling SkyView System Power

SkyView System Displays	Toggle SkyView System Power
One (1) display	Toggle primary power state OR Toggle display power by pressing and holding button 1
Multiple displays	Toggle primary power state OR Toggle all displays off or on by pressing and holding button 1 on each display.

27.3.2 Loss of Aircraft Power with SV-BAT-320 Connected

If external power is lost to a display that is connected to an SV-BAT-320 Backup Battery, it will either stay on for an additional 30 seconds or stay on indefinitely depending on whether or not the aircraft is in flight. This feature minimizes SV-BAT-320 discharge when on the ground and the master/external power is shut off normally while simultaneously reducing pilot workload during an actual in-flight power loss.

If the aircraft is not in flight, SkyView displays the message "POWERING DOWN IN xx SECONDS" while counting down from 30 seconds. During this countdown, the menu displays the buttons STAY ON and PWR OFF at the bottom of the screen. Press PWR OFF to turn off the SkyView display immediately. Press STAY ON to keep the SkyView display on via the connected SV-BAT-320. If STAY ON is pressed, the display will continue to use the SV-BAT-320 to power itself until the battery's charge is depleted or the display is turned off manually pressing and holding button number 1. Finally, if neither button is pressed before the countdown expires, the display will automatically turn off after 30 seconds to conserve the SV-BAT-320 charge.

If the aircraft is in flight, SkyView displays the message "AIRCRAFT POWER LOST" with no additional count down. This ensures that active pilot action is required to turn off a display when power is lost in-flight and SV-BAT-320 power is available. The STAY ON and PWR OFF buttons are still offered, but the display will stay on indefinitely unless PWR OFF is pressed.

27.3.3 How to Reboot the Display

Press and hold buttons 1, 2, and 5 simultaneously to instantly reboot the system. This may be helpful if you need to cycle power after changing certain settings and for general troubleshooting.

27.3.4 How to Manually Adjust the Screen Brightness

A SkyView display's backlighting (brightness) is primarily controlled by its ambient light sensor. If you have more than one (1) SkyView display, each display's ambient light sensor is incorporated. You can adjust the brightness / dimming to your preference by SCREEN > DIM to access the DIM Menu. To decrease or increase the backlight brightness press DEC- or INC+, respectively or simply rotate the knob labeled DIM – clockwise to brighten, counter-clockwise to dim. To set the backlight brightness to 100%, press FULL. SkyView will not allow you to dim the display(s) to a level that would cause it to be illegible for the ambient lighting conditions.

Reference Section 6.4.3 of this manual for instructions on specifying the display's backlight brightness control method.

27.3.5 How to Enter the Knob Function Menu

The Knob Function menus are used to specify which bug that knob adjusts if rotated. For example, Knob 1 could be set to adjust the Heading bug and Knob 2 could be set to adjust the Altitude bug.



Figure 140: Knob Menu

To set the function of a knob:

1. Push the knob (pushbutton) to enter the knob's Function Menu.
2. Choose the knob function by rotating the knob clockwise or counter-clockwise.
3. Confirm the highlighted function by pushing the knob (pushbutton),

OR

Wait approximately seven (7) seconds; the Function Menu will close, and the highlighted function will be selected.

If the Map Page is onscreen, the knob closest to the Moving Map is labeled (RNG) and is used to adjust the map's range. It cannot be assigned a different function.



If the Knob Function menu does not display all the Bugs that you wish to select from, it means some of the Bugs are disabled. To enable the desired Bugs, go to the PFD menu and select BUGS. In the BUGS menu, enable the desired bugs. Then the desired Bugs will be selectable in Knob menu.

27.3.6 How to Enter the Setup Menus

There are two (2) setup menus: The *Setup Menu* and the *In-Flight Setup Menu*. Simultaneously pressing and holding buttons 7 and 8 will open one (1) of these menus.

If the airspeed is zero, the Setup Menu will open. If the airspeed is greater than zero (0), the In-Flight Setup Menu will open.

You may also access the Setup Menu from the In-Flight Setup Menu by using the ENTER FULL SCREEN SETUP MENU option.

27.3.7 How to Adjust Time Zone Offset

First, configure the Top Bar to display time in SETUP MENU > LOCAL DISPLAY SETUP > TOP BAR SETUP > TIME: ZULU | LOCAL.

Then, adjust your preferred offset from the time currently displayed on the Top Bar – SETUP MENU > SYSTEM SETUP > TIME.

27.3.8 How to Configure Units of Measure

Displayed units can be configured for altitude, distance, speed, temperature, barometer, pressure, and volume. Displayed units are configured on the Measurement Units Page (SETUP MENU > SYSTEM SETUP > MEASUREMENT UNITS).

27.4 In Flight Setup Menu

This menu contains links that may be useful during flight:

- ADAHRS SOURCE SELECTION.
- FLIGHT ANGLE PITCH ADJUST.
- COMPASS CALIBRATION.
- AOA CALIBRATION.
- AUTOPILOT SETUP.
- ENTER FULL SCREEN SETUP MENU.

Note that *this menu occupies only half of the screen* and that all the links in the In-Flight Setup Menu are accessible via the SETUP MENU.

27.4.1 SETUP MENU

This menu contains links to system configuration options:

- SYSTEM EVENT.
- SYSTEM SOFTWARE.
- SYSTEM SETUP.
- LOCAL DISPLAY SETUP.
- PFD SETUP.
- EMS SETUP.
- MAP SETUP.
- AUTOPILOT SETUP.
- TRANSPONDER SETUP.

- TRAFFIC SETUP.
- ADS-B STATUS.
- COM RADIO SETUP.
- HARDWARE CALIBRATION.

Note that this menu occupies the entire screen. The menus above have menus of their own. The information in this section contains information on the purposes of each of the above menus, as well as a list of each menu's respective menus and their functions.



Pages and wizards that require users to do something have explicit onscreen instructions. Most actions are simple enough and onscreen instructions are more than adequate. In these cases, explicit instructions are not contained in this manual. In cases where onscreen instructions are not present, instructions are included in this manual.

The menu options descriptions in *this* section are intended to be *introductory / overview*, not comprehensive. Comprehensive explanations of menu options can be found *onscreen*, in the SkyView system, in the installation instructions in the specific section of this manual for each subsystem, such as SV-EMS-220 or SV-XPNDR-261.

27.4.2 SYSTEM EVENT Menu

The SYSTEM EVENT menu will only appear if the SkyView display detects that a "system event" has occurred on (one (1) of your) SkyView display(s).



Figure 141: System Event Display

If no critical system events have occurred on your SkyView display, "SYSTEM EVENT" will not appear as a menu item.

If a SYSTEM EVENT does appear, it will contain instructions on what to do next.

27.4.3 SYSTEM SOFTWARE Menu



You must have a USB flash drive that is recognizable by the display in one (1) of the USB slots to open this menu. All of the functions under this menu either write to or read from the flash drive.

Detailed instructions for all of the menus listed below are included in the Software Updates and File Operations Section of this manual.

The SYSTEM SOFTWARE Menu contains links to the following wizards:

- **UPGRADE SYSTEM SOFTWARE.** – Use this wizard to update Software on your SkyView system.
- **LOAD FILES** – Use this wizard to load files such as settings or configuration files or delete files from the USB flash drive.
- **EXPORT SETTINGS** – Use this wizard to export the settings on your SkyView system to a USB flash drive. Note that (as of V6.0) calibration settings are not exported, including servo calibrations, fuel tank calibrations, and compass calibrations.
- **EXPORT USER DATA LOGS** – Use this wizard to export user data logs in human-readable CSV format. See Appendix F: User Data Logs for further information about user data logs.
- **EXPORT USER WAYPOINTS** – Use this wizard to export all of the User Waypoints that are currently stored in your SkyView system.
- **EXPORT DYNON DIAGNOSTIC FILE** – This specialized data log can only be interpreted by Dynon Avionics personnel; there is no data in it that can be interpreted by SkyView pilots. Dynon Avionics Technical Support may request this log during troubleshooting, especially for issues related to AP performance. Note that this log is very big – over 500 MB – and takes minutes to save to a USB flash drive. Unless directed to export this log by Dynon Avionics, there is no reason to do so.

If you have more than one (1) SkyView display in your system, you may be requested to save the Dynon Avionics Diagnostic File from each of your SkyView displays, as each display can sometimes contain different diagnostic data. If you save the Dynon Avionics Diagnostic File from multiple displays onto the same USB flash drive, use the 33-character name field to distinguish the two (2) files, such as naming one file "LEFT" and the other file "RIGHT."

27.4.4 SYSTEM SETUP Menu

This menu contains menus and pages related to the entire SkyView system. When a setting is changed in one (1) of these menus, it is synchronized to other SkyView displays.

- SKYVIEW NETWORK SETUP – Enter this menu to configure your SkyView network or to check on network status (i.e., display important SkyView module information).
- WI-FI SETUP – Enter this menu to configure the Wi-Fi system – password, etc.
- SERIAL PORT SETUP – Enter this menu to configure the five (5) general purpose serial ports on all displays.
- AUDIO SETUP – Enter this menu to configure the options and volume for SkyView's audio output capability.
- AIRCRAFT INFORMATION – Enter this page to record important information regarding your aircraft. Specifically, enter the tail number of your aircraft – it is used to create unique SkyView configuration files. It is also used for other purposes. Note that for US planes, the leading N is a required part of the TAIL NUMBER. The TAIL NUMBER should not include dashes (-) or spaces.

Examples:

Correct: N12AB

Incorrect: N-42SV
or N 42SV

- MEASUREMENT UNITS – Enter this page to configure displayed units (e.g., feet or meters).
- TIME – First, configure the Top Bar to display time in SETUP MENU > LOCAL DISPLAY SETUP > TOP BAR SETUP > TIME: ZULU | LOCAL. Then, in this menu, adjust your preferred offset from the time currently displayed on the Top Bar.
- ARINC-429 – Enter this page to set up ARINC-429 devices connected to SV-ARINC-429 modules.
- SCREEN LAYOUT SETUP – Enter this page to configure the availability of the PDF Page, Engine Page, and Map Page on this display and throughout the system (when more than one (1) display is installed).
- PRIMARY COM – Select the COM radio to be displayed on the Top Bar and receive a frequency setting when the APT→COM button is pushed in the MAP MENU. If only one (1) COM radio is installed, this must be set. If two (2) COM radios are installed, only one (1) can be displayed on the Top Bar and receive a frequency setting when the APT→COM button is pushed in the MAP MENU.
- DISPLAY COM IN TOP BAR – Selects whether, or not, frequencies, PTT status, etc. from the COM radio (selected in PRIMARY COM, above) is displayed.
- DATA LOG SETUP – Enter this page to configure the recording frequency of SkyView's internal data logging feature, or to clear recorded data. See the User Data Logs Appendix for further information about user data logs.

27.4.5 LOCAL DISPLAY SETUP Menu

This menu contains menus and pages related to the individual SkyView display on which this menu is displayed. These settings can be different on one display from another display.

- **INSTALLED DATABASES** – Shows the various databases that are installed on this display and their respective versions.
- **DISPLAY HARDWARE INFORMATION** – Shows important hardware status information, such as the "Edition" of your SkyView display, the serial number of your display, and the voltage of the attached SV-BAT-320. Reference the Returning SkyView Components to Service after Repair Section of this manual for more information about the Display Hardware Information Page.
- **BRIGHTNESS SETUP** – Choose between manual, automatic, or external screen backlight control. Manual screen backlight control is managed by the user in the DIM Menu with the DEC-, INC+, and FULL buttons. Automatic screen backlight control is managed by a default dimming profile in the display. A compatible external control signal is required for external backlight control. Refer to the Brightness Setup Section for more information.
- **TOP BAR SETUP** – Configures the top bar on the SkyView display's screen.
- **GPS FIX STATUS** – Shows fix quality information for the GPS source that is being used as the active position source for SkyView's moving map and synthetic vision. Note that this does not show information about other GPS sources that may be available for HSI and backup position use.
- **BATTERY BACKUP (SV-BAT-320) STATUS** – Shows the status of automated tests of the SV-BAT-320.
- **LICENSE** – Shows the status of Software products that can be purchased and licensed to add features to SkyView. This page is also the place where license codes can be redeemed to activate features on your SkyView System.
- **VIDEO INPUT SETUP** – If a SkyView Video Input Adapter (USB) is connected to this display, options such as video input format and orientation can be selected. If a SkyView Video Input Adapter (USB) is not installed, this selection is grayed out and not accessible.

27.4.6 PFD SETUP Menu

This menu contains menus and pages related to Primary Flight Display page and data source (ADAHRS module).

- **ADAHRS SOURCE SELECTION**–This page has a list of all configured SkyView ADAHRS modules and their respective status. The ADAHRS module used as the PFD's source of data can be selected.

- FLIGHT ANGLE PITCH ADJUST – This page allows you to adjust the displayed pitch of the waterline symbol (aircraft reference on the attitude indicator) to compensate for the aircraft's attitude in level flight. That attitude can change depending on aircraft loading. This setting is not intended to compensate for an ADAHRS module that is not installed correctly.
- AIRSPEED LIMITATIONS – Enter this menu to configure the V-speeds and specify optimal flight parameters, such as the best angle of climb speed, the best rate of climb speed, and the optimum maneuvering speed.
- VERTICAL SPEED SCALE – Enter this page to configure the vertical speed tape's scale.
- G METER – Enter this page to configure G values that will cause the G Meter to be automatically displayed when exceeded; to set the yellow/red cautionary color ranges of the G meter; and whether or not the max/min recorded G's are reset at each SkyView boot-up.
- FLIGHT PATH MARKER – Enter this page to enable/disable display of the flight path marker.
- EXTREME PITCH WARNING – Enter this page to enable/disable display of the extreme pitch warning indicators.
- ANGLE OF ATTACK – Enter this page to enable/disable display of the Angle of Attack indicator.
- ALTITUDE BUG ALERTER – Enter this page to configure the altitude alerter, an audible alert when you are approaching or departing the altitude set in the ALT bug.
 - CAPTURE BAND: When the altitude of the aircraft flies within this range of feet/meters of the altitude bug (when displayed), SkyView will announce "approaching altitude" aurally (if audio output is configured).
 - DEVIATION BAND: When the altitude of the aircraft climbs above or descends below the altitude bug by the range of feet or meters set here, SkyView will announce "departing altitude" aurally (if audio output is configured).
- PFD MODE
 - LAYOUT
 - ALWAYS EFIS – The EFIS layout will always be displayed. The EFIS / SIX-PACK button is *not* present in the PFD > MODE menu.
 - SELECTABLE – the EFIS / SIX-PACK button *is* present in the PFD > MODE menu, allowing either EFIS or SIX-PACK layout on PFD.
 - WIDE ANGLE VIEW
 - ALWAYS NORMAL – The NORMAL view of the horizon on the PFD will always be displayed. The WIDE ON / OFF button is not present in the PFD > MODE menu.

- ALWAYS WIDE – The WIDE view of the horizon on the PFD will always be displayed. The WIDE ON / OFF button is not present in the PFD > MODE menu.
- SELECTABLE – The WIDE ON / OFF button is present in the PFD > MODE menu, allowing either WIDE or NORMAL views of the horizon on the PFD.
- BARO MISMATCH WARNING – Enables / disables a warning message when the current SkyView BARO setting and nearest valid ADS-B METARS report barometric pressure are significantly different.

27.4.7 EMS SETUP Menu



This menu is not accessible if an SV-EMS-220 is not installed. Reference the Section 10 of this manual for more information.

This menu contains menus and pages related to Engine Monitoring System page and data source (EMS module).

- ENGINE INFORMATION – Set important information regarding the engine in your aircraft such as engine type and horsepower. The user-entered information here is used to calculate quantities such as % power and special operating limitations.
- SENSOR INPUT MAPPING... – This wizard configures the individual multipurpose pins of the SV-EMS-220(s) to specific engine and environmental sensors.
- SCREEN LAYOUT EDITOR – This wizard configures the placement and style of the onscreen EMS gauges on EMS pages. Reference the EMS Sensor Calibration
- Fuel level sensors and position potentiometers must be calibrated. Your SkyView display utilizes onscreen wizards that help you do this. Go to the EMS Calibration Menu to access these wizards (SETUP MENU > HARDWARE CALIBRATION > EMS CALIBRATION).
- EMS Screen Layout Editor section of this manual for instructions on how to use this wizard.
- SENSOR SETUP – Configures the ranges, alarm conditions, and graphical display properties of sensors. Reference the EMS Sensor Calibration
- Fuel level sensors and position potentiometers must be calibrated. Your SkyView display utilizes onscreen wizards that help you do this. Go to the EMS Calibration Menu to access these wizards (SETUP MENU > HARDWARE CALIBRATION > EMS CALIBRATION).
- EMS Screen Layout Editor section of this manual for instructions on how to use this wizard.
- SENSOR DEBUG DATA – Displays diagnostic / troubleshooting data for engine sensors. Also displays the version of the EMS Sensor Definitions file loaded on this SkyView display. See Appendix G: Sensor Debug Data for how to interpret the information displayed on this page.

27.4.8 MAP SETUP Menu

This menu contains menus and pages related to MAP page and data sources.

- TERRAIN WARNING COLORS – Sets whether Red and Yellow terrain warning are provided on the Map Page.
- RED AND YELLOW START – When the above setting is set to "YES", these settings how far above or below the aircraft's current altitude the red and yellow colors persist.

27.4.9 AUTOPILOT SETUP Menu



This menu is not accessible until the autopilot servos in the system have been successfully calibrated and tested. Reference Section 18 of this manual for more information.

This menu configures various aspects of the Dynon Avionics Autopilot system:

- STATUS – Displays diagnostic / troubleshooting information for the AP system.
- AUTOPILOT CONTROLS – Chooses the EXPERT or SIMPLIFIED mode. Note that the EXPERT mode must be selected for the Dynon Avionics SV-AP-PANEL to be active.
- ROLL AXIS – Roll axis setup and tuning parameters.
- PITCH AXIS – Pitch axis setup and tuning parameters.
- DISENGAGE BUTTON – Configure disengage button options such as 'hold to engage,' 'enable broken line detect,' and 'control wheel steering mode.'
- FLIGHT DIRECTOR – Chooses the SINGLE CUE (INVERTED V) or DUAL CUE (CROSS BARS) mode of flight director to be displayed on the PFD.

27.4.10 TRANSPONDER SETUP Menu



This menu is not accessible unless an SV-XPNDR-261 is setup and configured. Reference the SV-XPNDR-261 Transponder Section of this manual for more information.

This menu contains options that are used to set up and configure the SV-XPNDR-261 module.

27.4.11 HARDWARE CALIBRATION Menu

This menu contains links to the following menus:

- ADAHRS CALIBRATION – Enter this menu to make altitude adjustments (e.g., Baro and altitude offset) and access the compass and AOA calibration wizards.
- EMS CALIBRATION – Enter this menu for EMS sensor calibration. You will have options to calibrate fuel tanks and position potentiometers that have been mapped in the Sensor Input Mapping Wizard. Calibration wizards contain onscreen instructions.

- AP SERVO CALIBRATION – Enter this menu for autopilot servo calibration. Reference the Section of this manual for more details.
- TRIM MOTOR CONFIGURATION – Enter this menu to configure one (1) or two (2) trim motors (connected to / powered by the Dynon Avionics SV-AP-PANEL 15-pin connector) for automatic trim control (Autopilot Auto-trim) during AP operation.



Note that if ADAHRS, EMS, or Servos are not present on the SkyView network, this menu will note the absence by displaying "(EMS NOT DETECTED)", "(ADAHRS NOT DETECTED)", or "(SERVOS NOT INSTALLED)."

27.5 Software Updates and File Operations

Dynon Avionics continually provides new functionality and capabilities to your SkyView system via Software updates. Use the resources mentioned in the Contact Information Section of this document to stay current on Software availability for SkyView.

The airplane owner/operator can install preventative software updates, but only an FAA-credentialed mechanic or facility can install non-preventative software updates. Software updates are installed using a USB flash drive. See dynoncertified.com/download for more information.



USB Flash Drive Considerations

A 4 GB or 8 GB USB flash drive is shipped with each SkyView display. There is nothing unique about this USB flash drive, including the data on it. Dynon Avionics recommends that you have a variety of USB flash drives available for various purposes, to dedicate to a specific task. For example, maintain a separate USB flash drive for EXPORT SETTINGS files; another for updating Software, and another for updating Aviation / Obstacle databases, etc. While a high-resolution terrain database may require as much as 4 GB, a SkyView Software update may require only 50 MB. To display Seattle Avionics charts, a 16 GB USB flash drive is required. For most purposes, such as saving data logs and typical updates, A 1 GB or 2 GB USB flash drive will be adequate.

Dynon Avionics recommends the use of "name brand" USB flash drives – "house brand" USB flash drives can sometimes fail prematurely, causing corrupted files or lost data. If it is ever necessary to reformat a USB flash drive, the format that is compatible with SkyView is "FAT32."

In order to open the SYSTEM SOFTWARE Menu, you must have a USB flash drive plugged in to your SkyView display.



Updating the Software on a SkyView display automatically updates all the modules connected on the same SkyView network, except for other SkyView displays. Each display must be updated individually.

Prior to updating Software, all SkyView Network devices must be powered on and online. If all previously configured SkyView Network devices are not

detected, a warning screen will appear. The most common cause for this error is that power is off to the autopilot servos (AP switch not ON). As soon as the offline module(s) resume(s) communicating with SkyView, the Software update will automatically proceed. (SkyView Network devices do not include SV-ADSB-472/472 and SV-XPNDR-261 – those devices are connected via serial ports).

27.5.1 How to Update Software

1. Download the latest SkyView Software file from dynoncertified.com/download.
2. Copy the Software file onto your USB flash drive. *The Software file must be in the root directory of the drive, to be recognizable by the SkyView display.*
3. Insert the USB flash drive into one (1) of the SkyView display's USB ports.
4. SETUP MENU > SYSTEM SOFTWARE > UPGRADE SYSTEM SOFTWARE...)
> (one (1) more right click).



If some SkyView Network modules (or other displays) are not powered on or connected to the SkyView network, you will see a screen that is like below.



Figure 142: Some SkyView Network devices not online, cannot update

If you see a screen like the one (1) in Figure 142 above, power on or reconnect all SkyView Network devices. This error is typically caused by Autopilot servos or the SV-COM-X25/X83 radio not being powered on.

5. Update the Software on the unit by pressing UPDATE or press CANCEL to return to the SYSTEM SOFTWARE Menu.

6. To aid in troubleshooting, during the Software update process, your SkyView system's previous configuration files are automatically written to the USB flash drive in a subdirectory (folder) called "settings_archive":

TAILNUMBER_SNXXXX_SOFTWAREVERSION_SENSORS_SW_UPGRADE.sfg

TAILNUMBER_SNXXXX_SOFTWAREVERSION_SW_UPGRADE.sfg

27.5.2 How to Export System Settings



This operation creates a set of files on the USB flash drive that contain display settings, equipment settings, and important calibration information. All the filenames contain the tail number and the Software version.

1. Insert the USB flash drive into one (1) of the display's USB sockets.
2. Go to the Export Settings Wizard (SETUP MENU > SYSTEM SOFTWARE > EXPORT SETTINGS...).
3. Create a file name for the settings file.
4. Save the settings file onto the flash drive by pressing EXPORT or press CANCEL to return to the SYSTEM SOFTWARE menu.

27.5.3 How to Load and Delete Files

1. Download file from dynoncertified.com/download such as terrain or EMS files or use another source for the SkyView file.
2. Copy the file onto your USB flash drive. *The file must be in the root directory of the drive, to be recognizable by the display.*
3. Insert the USB flash drive into one (1) of the display's USB sockets.
4. Go to the Load Files Wizard (SETUP MENU > SYSTEM SOFTWARE > LOAD FILES...).
5. Select a file and press:
 - a. LOAD to load the file onto the system.
 - b. CANCEL to return to the SYSTEM SOFTWARE menu.
 - c. REMOVE to delete the file from the USB flash drive.

27.5.4 How to Export Data Logs and Waypoints

EXPORT DATA LOGS

Data logging, and how to export data logs is discussed in depth in Appendix F: User Data Logs.

EXPORT USER WAYPOINTS

This option exports all the User Waypoints that are currently stored in your SkyView system.

EXPORT DYNON DIAGNOSTIC FILE

This specialized data log can only be interpreted by Dynon Avionics Engineers; there is no data in it that can be interpreted by SkyView pilots. Dynon Avionics Technical Support may request this log during troubleshooting, especially for issues related to AP performance. Note that this log is very big – over 500 MB – and takes minutes to save to a USB flash drive. Unless directed to export this log by Dynon Avionics, there is no reason to do so. This file is too large to send in an email message.

If you have more than one (1) SkyView display in your system, you may be requested to save the Dynon Avionics Diagnostic File from each of your SkyView displays as each display can sometimes contain different diagnostic data. If you save the Dynon Avionics Diagnostic File from multiple displays onto the same USB flash drive, use the 33-character name field to distinguish the two (2) files, such as naming one (1) "LEFT" and the other one (1) "RIGHT."

If Dynon Avionics Technical Support has requested that you send a Dynon Diagnostic File, go to dynon.com/datalogs to transmit the file to Dynon Avionics. Please reference any previous communications with Dynon Avionics Technical Support such as Case number, RMA number, etc.

28 Navigation Mapping Setup

28.1 Features Overview

The following features are enabled if SkyView has a valid GPS position signal, the appropriate high resolution terrain database installed for the region of the world that you are flying in, and aviation database installed.

- Use of MAP menu and features, including:
 - Display of airport, airspace, obstacles, traffic, and other aviation data that is available (capabilities depend on available databases and other installed equipment).
 - Display of procedure charts, airport diagrams, enroute charts (sectionals), and other layers that can be overlaid on the map.
 - Display of base map features, including roads, city names, railroads, rivers, and political boundaries.
 - All Navigation Mapping features available via the MAP menu.
 - Display of obstacles and runways on Synthetic Vision (if Synthetic Vision is licensed).
 - All future updates to the SV-MAP-270 Navigation Mapping License.

28.2 Databases

SkyView utilizes a variety of databases to display information on the moving map and present options for navigation. These include:

- Charts: Scanned or electronic versions of procedure charts, airport diagrams, and enroute charts. Seattle Avionics data available for US SkyView pilots. PocketFMS, OzRunways, and AvPlan EFB data available for other worldwide SkyView pilots.
- Aviation data: Airports, navigation aids, airspace, airport information, etc. Available for free for US SkyView pilots from Dynon Avionics. Jeppesen and PocketFMS data available for all other SkyView pilots worldwide.
- Obstacles data: Available for free for US SkyView pilots from Dynon Avionics. Jeppesen and PocketFMS data available for all other SkyView pilots worldwide.
- Terrain data: A high resolution terrain database is used to display the topographic map. Available worldwide for free from Dynon Avionics.
- Base map (Cultural) data: Base map is available for free for all SkyView pilots from Dynon Avionics worldwide.
- Stadium TFR data: Available for free for US SkyView pilots from Dynon Avionics.

The airplane owner/operator or an appropriately-rated technician can install databases, charts, and diagrams. Data updates are installed using a USB flash drive. See dynoncertified.com/download for more information.

28.2.1 Viewing Information about Installed Databases

The Installed Databases Page (SETUP MENU > LOCAL DISPLAY SETUP > INSTALLED DATABASES) allows users to see the databases installed on their equipment as well as their respective versions and expiration dates. The sections below outline the various databases that are installed in SkyView.



When viewing INSTALLED DATABASES, the sections:

- PROCEDURE CHARTS AND AIRPORT DIAGRAMS,
- FLIGHT GUIDE AIRPORT DIAGRAMS, and
- ENROUTE CHARTS,

can only display information about these databases if the USB flash drive (with the PocketFMS / Seattle Avionics chart data) is plugged in. When the USB flash drive with this data is not plugged in, these sections are blank.

For any database which has an expiration date, if the expiration date has passed,

- On a SkyView display, a popup message will appear on the MAP page as shown in Figure 143. This message can be cleared by pushing the MAP button and then the ACCEPT button. The popup message is then cleared for the remainder of the time SkyView is powered on. Until the database whose expiration date has passed is updated, this popup message will continue to appear each time SkyView is powered on. The initial appearance of this popup message cannot be suppressed. Note that in the popup message, only the *first* database that is past its expiration date is listed.
- The presence, and status (including expiration dates) of all databases can be checked in the INSTALLED DATABASES page: SETUP MENU > LOCAL DISPLAY SETUP > INSTALLED DATABASES. Any database that has expired will be shown in **YELLOW** and appended with (EXPIRED), as shown in Figure 144. Note that in a SkyView system with multiple displays, it is possible for each display to have different, and different versions (expiration dates) of various databases. Thus, when verifying the presence, and expiration dates, of databases, check them on each SkyView display.



Figure 143: SkyView Database Expired Popup Message



Figure 144: Aviation Database Expired Caution Message (Lower Left Corner of Display)



Figure 145: SkyView INSTALLED DATABASES with Expired Database Shown in Yellow

28.2.2 Terrain Database

SkyView uses high resolution terrain databases to display the base topographic map on the MAP page, as well as to display Synthetic Vision on the PFD page. The Skyview HDX displays are shipped with terrain databases for North America (includes the continental United States, part of Alaska, most of Canada, Mexico, part of Central America, and the West Indies). Dynon Avionics offers downloadable high resolution terrain database files for other regions of the world on its website at dynoncertified.com/download.

To update the terrain databases in a SkyView display, download the appropriate file onto a USB flash drive (a 4 GB drive is included with every SkyView display) and then reference the How to Load and Delete Files Section of this manual for instructions on how to import the file onto a SkyView display. Because the terrain databases are large, only one (1) can be installed in a SkyView display at a time. A large USB flash drive can hold multiple terrain databases for different regions of the world. However, each region’s coverage area is chosen to cover most pilots’ needs without having to ever switch between regions. Loading a new high resolution terrain database will automatically delete the one (1) previously installed on your SkyView display.

If SkyView detects that it is in an area outside of the boundaries of the high-resolution terrain database currently installed on SkyView, a Caution message will be displayed: NO HI-RES TERRAIN.

This occurs most often outside North America as SkyView is (typically) shipped from the factory with a high-resolution terrain database for North America. To correct this issue, install the high-resolution terrain database for your region.



If you have difficulty downloading the very large regional high-resolution terrain databases using a web browser, particularly using a slow Internet connection, alternatively, you may use an "FTP" client, such as FileZilla, available at <https://filezilla-project.org>.

Host: dynonavionics.com

Username: anonymous

Password: (blank)

28.2.3 Aviation/Obstacle Databases

Aviation and obstacle databases are used to display airports, runways, navigation aids, airspace, obstacles, and other aviation data on the moving map. It also makes allows SkyView to provide detailed information about aviation features. SkyView can also provide navigation to these aviation features.

28.2.3.1 Free Dynon Avionics Aviation and Obstacle Data (U.S. Only)

Aviation and Obstacle data is available free-of-charge for US SkyView pilots. Go to dynoncertified.com/download to download these databases to a USB flash drive. Reference the Loading Databases section of this manual below for instructions on how to import the file onto a SkyView display. Aviation data is updated every 28 days. Obstacle data is updated every 56 days.

28.2.3.2 PocketFMS AeroData Subscriptions with Obstacles and Visual Reporting Points (Worldwide)



AeroData is professionally maintained and updated for SkyView every 28 days and is available as a yearly subscription including obstacles for €119. Coverage encompasses Europe, North America (including Canada), Australia, and New Zealand. It includes Aviation data (including visual reporting points) and obstacle data. As of August 2015, enroute charts are also available from PocketFMS. To order and download PocketFMS AeroData, visit their website at [http://www.pocketfms.com/Dynon Avionics](http://www.pocketfms.com/Dynon_Avionics)

28.2.3.3 Jeppesen NavData® and Obstacle Data Services (Worldwide)



Aviation and Obstacle for SkyView pilots outside the US is available from Jeppesen. To purchase Jeppesen data:

- Visit <http://www.JeppDirect.com/viewavionics> for data subscription information from Jeppesen for your SkyView display.
- To order service, please call Jeppesen at a number below.

Table 56: Jeppesen Telephone Numbers

U.S. & Canada	United Kingdom	Europe (except UK), Middle East, Africa and Asia	Australia
Toll-Free: 1-866-498-0213 Direct: 1-303-328-4030	Toll-Free: 0 (800) 085 5377 Direct: +44 129 384 2400	Toll-Free: 0 800 5377 3736 Direct: +49 6102 5070	Direct: +61 261 202 999

- Reference the Loading Databases section below of this manual for instructions on how to import the file onto a SkyView display.

Additional technical support from Jeppesen can be found online at <http://www.jeppesen.com/support/technical-support.jsp>.

28.2.4 Stadium TFR Database (U.S. Only)

Dynon Avionics includes a Stadium TFR database as part of its "Quick Packages" for US pilots. In loading any "Quick Package" since then, the Stadium TFR database will be loaded onto a SkyView system. After the Stadium TFR database is loaded, a TFR will be displayed on the MAP PG as if it was being received via ADS-B. The default opacity of the Stadium TFR database (as displayed on the MAP PG) is 100% (solid Red) but can be adjusted: MAP MENU > MAP ITEMS > TFR OPACITY.

If the Stadium TFR database is accidentally deleted from a SkyView display, contact Dynon Avionics Technical Support to obtain a replacement Stadium TFR database.

28.2.5 Charts and Airport Diagrams

SkyView's charting capabilities allow pilots to quickly find and display the procedures they need during flight, all while showing the aircraft's position and track right on the chart itself. With the touch of a button, SkyView automatically loads the available airport diagram while on the ground.

28.2.5.1 Geo-Referenced Charts and Airport Diagrams, Geo-referenced US sectionals, and IFR HI and LO Charts (U.S. Only)



SkyView HDX can display geo-referenced charts and airport diagrams provided by Seattle Avionics, including over 5,000 FlightGuide diagrams and all approach plates and procedures. SkyView supports Seattle Avionics geo-referenced US sectionals and IFR HI and LO charts. Subscriptions for all Seattle Avionics data listed above for SkyView pilots are available at a special price. To order and download Seattle Avionics' SkyView ChartData,

contact Seattle Avionics – call 425-806-0249 or see

<http://www.seattleavionics.com/ChartData/Default.aspx?TargetDevice=Dynon Avionics>

28.2.5.2 European Charts and Airport Diagrams (Europe)



PocketFMS' Frequent Flyer membership includes AeroData, charts (including Pooleys in the UK), airport diagrams, visual approach, landing, and area charts, costs €150 per year. This is only €31 more than the existing SkyView AeroData-only subscription (which remains available). As of August 2015, enroute charts are also available from PocketFMS. To become a PocketFMS Member (Frequent Flyer membership), see <http://www.pocketfms.com/Dynon/>.

28.2.5.3 Australia and New Zealand Charts (Australia, New Zealand)



SkyView supports Australia and New Zealand charts from OzRunways (<https://www.ozrunways.com>) and AvPlan EFB (<http://www.avplan-efb.com>). Please contact these companies directly for more information about the specific data they provide, pricing, purchase / subscription options, and support on saving their data onto a USB flash drive for use with SkyView.

28.2.6 Base Map (Cultural Data)

Base Map (Cultural Data) is available free-of-charge for all SkyView pilots for SkyView pilots worldwide. The Base Map contains roads, city names, railroads, rivers, and political boundaries. Like the terrain database, it is partitioned into different regions. Download the base map database for your region from dynoncertified.com/download to a USB flash drive. Reference the section below for instructions on how to import the file onto a SkyView display.

28.2.7 Loading Databases

1. Download database file(s) from dynoncertified.com/download, Jeppesen, or PocketFMS.
 - a. If you've downloaded data from the Dynon Avionics website or PocketFMS: Copy the file onto your USB flash drive. *The file must be in the root directory of the drive in order to be recognizable by the display*
 - b. If you've purchased data from Jeppesen: It is important that the Jeppesen JSUM program is used to place the Jeppesen data on the USB flash drive that will be used to load the data onto SkyView. If you manually copy Jeppesen data onto a USB flash drive, it will not load onto your SkyView system.
2. Insert the USB flash drive into one (1) of the display's USB sockets.

3. Go to the Load Files Wizard (SETUP MENU > SYSTEM SOFTWARE > LOAD FILES...).
4. Select a file and press:
 - a. LOAD to load the file onto the system.
5. Exit Setup.
6. In SkyView systems that have more than one (1) display, databases are automatically synchronized to other connected displays provided that those displays are connected via Ethernet. If they are, and you have the MAP page up on other displays, you may see a SYNCHRONIZING DATABASES message appear as this process occurs, followed by a display reboot. If you do not have your displays connected via Ethernet, simply load the database to each screen individually.

28.2.8 Removing Databases

SkyView automatically removes old databases when new databases are installed. Databases can also be removed manually by going to SETUP MENU > LOCAL DISPLAY SETUP > INSTALLED DATABASES. Highlight the database you wish to remove, and then press the REMOVE button.



Aviation Data updates are published periodically by Dynon Avionics, PocketFMS, and Jeppesen. It is the user's responsibility stay current with these updates and keep their equipment up to date.

29 Appendix A: Maintenance and Troubleshooting

This appendix provides builders, installers and technicians basic information regarding SkyView maintenance and troubleshooting.

Dynon Avionics' Internet sites may provide more up-to-date information on maintenance and troubleshooting than this document. The following sites should be used as a reference:

- dynoncertified.com/docs – Dynon Avionics' documentation download area allows SkyView pilots (and prospective SkyView pilots) to download the most up-to-date versions of all Dynon Avionics documentation. Older versions of Dynon Avionics documentation may be shipped with OEM and dealer-provided units, so it is a good idea to periodically check for new versions of documentation.
- forum.flydynon.com Dynon Avionics' Online Customer Forum is a resource for Dynon Avionics SkyView pilots to discuss installation and operational issues relating to Dynon Avionics products. The Forum is especially useful for pilots with uncommon aircraft or unusual installation issues. For SkyView pilots that cannot call Dynon Avionics Technical Support during our normal business hours, the Forum is a convenient way to interact with Dynon Avionics Technical Support. The Forum allows online sharing of wiring diagrams, photos, and other types of electronic files.
- Dynon Avionics Technical Support – Phone: +1 (425) 399-7742, 8:00 AM – 5:00 PM (Pacific Time) Monday – Friday Email: support@dynoncertified.com.



There are no user-serviceable parts (such as replaceable fuses) inside any SkyView system unit. Refer all servicing to Dynon Avionics.

29.1 Cleaning a SkyView Display



Do not clean SkyView displays or panel units with solvents such as alcohol. If solvents are used, the silk screen lettering on the bezel can be removed, and the display's anti-glare coating can be damaged. Damage from the use of solvents is not covered by warranty.

29.2 Saving a Screenshot of a Specific Screen

It is sometimes helpful to have a screenshot of a behavior to share with Dynon Avionics Technical Support. Screenshots recorded with this method are far superior to photos because they are always "in focus" and they include *all* the detail on screen. Screenshots are also useful to have for your records for how your SkyView display was configured, especially detailed menus such as Serial Port Setup, Sensor Input Mapping, etc. To accomplish this:

- Insert a USB flash drive into your SkyView USB port.
- When you want to save a screenshot of the display, press buttons 2 and 7 on that display simultaneously. SkyView will display a message indicating that a screenshot has been saved.
- The screenshot can be found in the "screenshots" folder on the USB flash drive when the USB flash drive is connected to a computer.
- If a Language Pack is installed, two (2) screen shot files will be saved to the USB flash drive – one (1) in English, and one (1) in the language of the Language Pack.
- If requested by Dynon Avionics Technical Support, email the screenshot files to: support@dynonavionics.com.

29.3 Savings a Settings File (Configuration of your SkyView system)

It is sometimes helpful to send your system configuration settings to Dynon Avionics Technical Support. A settings file is also useful to have for your records for how your SkyView display was configured. With a Settings File, a new SkyView display can be mostly restored by loading this file. To accomplish this:

- Insert a USB flash drive into your SkyView USB port.
- SETUP MENU > SYSTEM SOFTWARE > EXPORT SETTINGS... > (one (1) more right click).
- For your records, put the USB flash drive (or at least the files) in a safe place.
- If requested by Dynon Avionics Technical Support, email the settings files to: support@dynoncertified.com.

29.4 Saving a Dynon Diagnostic File

In rare cases, Technical Support will request you to send a Dynon Avionics Diagnostic File. To accomplish this:

- Insert a USB flash drive into your SkyView USB port.
- SETUP MENU > SYSTEM SOFTWARE > EXPORT DYNON DIAGNOSTIC FILE... > (one (1) more right click).

- This file is too large to send in an email message. If Dynon Avionics Technical Support has requested that you send a Dynon Diagnostic File, go to dynon.com/datalogs to transmit the file to Dynon Avionics. Please reference any previous communications with Dynon Avionics Technical Support such as Case number, RMA number, etc.

29.5 SkyView Displays Error: SYS EVENT 5: SEE SETUP

System Event 5 indicates that the SkyView display's internal Solid-State Disk (SSD) is experiencing an abnormal number of errors, and thus should be replaced. This feature was added to help detect units that may have potential problems with rebooting in flight or possible screen freezes.

The repair of the internal SSD can only be performed at the Dynon Avionics factory. Repair of SkyView displays for System Event 5 is considered a Warranty Repair, regardless of whether your SkyView display's warranty is still in effect or has expired. To arrange for a Return Material Authorization (RMA) for repair of your SkyView display for System Event 5, contact Dynon Avionics Technical Support (contact information at the beginning of this manual).

Before removing your SkyView display to ship to Dynon Avionics, please perform the following procedure to save a backup of your most important settings. You will need a USB flash drive (memory stick) - capacity of 1 GB is adequate, available inexpensively at most office supply and grocery stores. We recommend that you save these files to a USB flash drive not used for anything else.

1. Manually record your HOBBS and TACH time, as these two (2) pieces of information are not saved in the backup file.
2. Power up the SkyView display / system.
3. If you have another USB flash drive inserted into this SkyView display, temporarily remove it (SkyView can only "see" one (1) USB flash drive at a time).
4. Insert the "backup" USB flash drive on the SkyView display you will be sending in for trade-in.
5. Push buttons 7+8 together to enter the SETUP MENU.
6. SETUP MENU > SYSTEM SOFTWARE > EXPORT SETTINGS > (fill in the blank - suggest FINAL BACKUP) > EXPORT (button). The settings files will be saved to the USB flash drive.
7. After the export is complete, remove the USB flash drive.
8. Power down the SkyView display.
9. Put the USB flash drive in a safe place.

If the worst happens - your SkyView display is damaged or lost in transit, this will allow you to restore MOST settings of your SkyView system.

29.6 Returning SkyView Components to Service after Repair

SkyView Network enabled components such as modules and servos are shipped in a "like new" state after repair. To return a SkyView Network component to SkyView Network, follow the following directions. Note that there are three (3) different procedures for returning SkyView displays to service, depending on how the display is returned:

29.6.1 SkyView Display Scenario 1

When the documentation furnished with the repaired display indicates that is being returned to you with the exact same settings/configuration as it was sent to Dynon Avionics with

1. In this case, the display contains THE same configuration as it did when you sent it in. If your system was working properly before the display failed and was sent in for repair:
 - a. Reinstall the display, reconnecting all harnesses and connections as originally installed.
2. Power up the entire SkyView System (all displays, modules, servos, etc.)
3. If this is the only display installed:
 - a. Reconfigure SkyView Network under SETUP MENU > SYSTEM SETUP > SKYVIEW NETWORK SETUP > CONFIGURE...
 - b. Confirm all SkyView Network components are found, including ALL displays that are in the aircraft.
4. If there is another display installed in the aircraft:
 - a. Using a display that never left the aircraft (and is presumably configured and working correctly):
 - i. Reconfigure SkyView Network under SETUP MENU > SYSTEM SETUP > SKYVIEW NETWORK SETUP > CONFIGURE...
 - ii. Confirm all SkyView Network components are found.
5. Confirm that all settings, behavior, and configuration are normal.
6. If your SkyView system is not working normally, contact Dynon Avionics Technical Support (contact information at the beginning of this manual) for further assistance.

29.6.2 SkyView Display Scenario 2

When repaired display is the ONLY display in the aircraft, and the documentation furnished with the repaired unit indicates that the display was shipped "like new:"

1. Reinstall the display, reconnecting all harnesses and connections as originally installed.
2. Power up the entire SkyView System (all displays, modules, servos, etc.).
3. If you have an EXPORT SETTINGS file on a USB flash drive:

- a. Load the EXPORT SETTINGS file via SETUP MENU > SYSTEM SOFTWARE > LOAD FILES.
 - b. Confirm that the tail number under SYSTEM SETUP > AIRCRAFT INFORMATION is now set to the actual aircraft tail number, not DYNON. TAIL NUMBER should not include dashes (-) or spaces. Examples:
Correct: N12AB
Incorrect: N-12AB or N 12AB
 - c. Reconfigure SkyView Network under SETUP MENU > SYSTEM SETUP > SKYVIEW NETWORK SETUP > CONFIGURE.
 - d. Confirm all SkyView Network components are found.
 - e. Confirm all settings, calibrations, and behaviors are as expected. Dynon Avionics recommends using the Installation Manual to walk through each set up section to confirm proper system operation.
4. If you do not have an EXPORT SETTINGS file, use the SkyView Installation Manual to perform ALL setup and configuration steps as if the entire system is being installed for the first time.

29.6.3 SkyView Display Scenario 3

When other display is part of a multi-display system in the aircraft, and the documentation furnished with the repaired unit indicates that the display was shipped "like new"

1. Your repaired display will have the latest version of SkyView Software on it. All displays in the aircraft must be on the same SkyView Software version. Therefore, before doing anything with the repaired display, confirm that your OTHER (still installed) SkyView displays are running the latest system Software by comparing the version available at dynoncertified.com/download with the version that is listed in SETUP MENU > LOCAL DISPLAY SETUP > DISPLAY HARDWARE INFORMATION. If the version displayed here does not match what is available on the web site, update these displays to the most current version of Software before proceeding further. Instructions for updating your displays can be found in the Software Updates and File Operations section of this manual.
 - a. If you must updated SkyView Software, look through all the settings in the SETUP MENU after the update, as there may be some new options. Use the Revision History at the beginning of the SkyView System Installation Manual to help determine what has changed between versions.
2. Reinstall the repaired display, reconnecting all harnesses and connections as originally installed.
3. Power up the entire SkyView System (all displays, modules, servos, etc.).
4. From the display that never left the airplane, save your settings files to a USB flash drive by using SETUP MENU > EXPORT SETTINGS ...

5. Move this USB flash drive to the repaired display, and load both the .dfg and .sfg files that were created on the USB flash drive by using SETUP MENU > SYSTEM SOFTWARE > LOAD FILES...
6. Set the tail number of the repaired display (SYSTEM SETUP > AIRCRAFT INFORMATION) to DYNON AVIONICS.
7. Going back to a display that never left the aircraft, which is configured properly and working correctly:



It is important that the following steps are done from a display which has remained in the aircraft, and NEVER the newly repaired display. If network configuration is done from the repaired display, it is possible for it to overwrite the correct settings that are stored in your good display with the Dyon Avionics default factory settings.

- a. On the display that stayed in the plane, confirm that the tail number under SYSTEM SETUP > AIRCRAFT INFORMATION is set to the actual aircraft tail number, not DYNON.
 - b. On the display that stayed in the plane, reconfigure SkyView Network under SETUP MENU > SYSTEM SETUP > SKYVIEW NETWORK SETUP > CONFIGURE.
 - c. Confirm all SkyView Network components are found, including ALL displays that are in the aircraft.
 - d. Exit Setup mode.
8. On the recently repaired display, confirm that the tail number under SYSTEM SETUP > AIRCRAFT INFORMATION is now set to the actual aircraft tail number, not DYNON. This implies that all settings and configurations have been synchronized from the other display.

29.7 Multi-display SkyView System, Continuing to Fly with a Missing Display

In a multi-display SkyView system, the system can continue to operate with only one (1) SkyView display. However, this capability depends on all SkyView Network connections being intact so that the remaining SkyView display is electrically connected to all SkyView Network devices.

Each SkyView display has two (2) SkyView Network connections on the back. In the event of a failure of a SkyView display, the two (2) SkyView Network connectors are "electrically common"; even if the SkyView display is failed or powered off, all pins of the upper connector are electrically connected to all pins of the lower connector.

If both SkyView Network connectors are used, when the SkyView display is removed, there is a "disconnect" from the SkyView Network devices connected to the upper SkyView Network connector, and the lower SkyView Network connector.

This is most easily remedied by the installation of a D9M-to-D9M adapter (Figure 146, pictured at right) to "bypass" the removed SkyView display's SkyView Network connections. This connector connects Pin 1 to Pin 1, Pin 2 to Pin 2, etc. This adapter "electrically replaces" the missing SkyView display to allow the remaining SkyView display to communicate with all SkyView Network devices. This adapter can also be easily fabricated with 2 D9M connectors – connect all pins "straight through" – Pin 1 to Pin, Pin 2 to Pin 2, etc.



Figure 146: Example of Network Bypass Adapter

If only *one* (1) SkyView Network connector is used on the back of the SkyView display is used, then there is no impact to the SkyView Network from the removal of that SkyView display.

29.7.1 SV-ADAHRS-200 Module

1. Reinstall the ADAHRS in the aircraft.
2. Reconnect all harnesses and connections as originally installed.
3. Power up the entire SkyView System (all displays, modules, servos, etc.).
4. From any display in the aircraft, reconfigure SkyView Network under SETUP MENU > SYSTEM SETUP > SKYVIEW NETWORK SETUP > CONFIGURE.
5. Confirm all SkyView Network components are found, including the reinstalled ADAHRS.
6. If the ADAHRS is the same serial number as the ADAHRS you returned for repair, no further actions should be required. However, Dynon Avionics recommends double checking the performance of compass and AOA calibration. If these do not seem to work as well as they previously did, redo those calibrations.

If the ADAHRS is not the same serial number as the ADAHRS you returned for repair, all setup and calibration steps should be performed because this ADAHRS is being installed for the first time.

29.7.2 Autopilot Servos

1. Reinstall the servo in the aircraft.
2. Reconnect all harnesses and connections as originally installed.
3. Power up the entire SkyView System (all displays, modules, servos, etc.).
4. From any display in the aircraft, reconfigure SkyView Network under SETUP MENU > SYSTEM SETUP > SKYVIEW NETWORK SETUP > CONFIGURE...
5. Confirm all SkyView Network components are found, including the reinstalled servo.

6. Assuming the Autopilot was previously set up and working correctly, you only need to recalibrate the servos by going to SETUP MENU > HARDWARE CALIBRATION > AP SERVO CALIBRATION > CALIBRATION and following the on-screen instructions.

29.7.3 All other SkyView Network Components

1. Reinstall the SkyView Network component in the aircraft.
2. Reconnect all harnesses and connections as originally installed.
3. Power up the entire SkyView System (all displays, modules, servos, etc.).
4. From any display in the aircraft, reconfigure SkyView Network under SETUP MENU > SYSTEM SETUP > SKYVIEW NETWORK SETUP > CONFIGURE.
5. No further action should be required.

29.8 Operational Status

SkyView displays give users access to vital operational information in the Display Hardware Information Page (SETUP MENU > LOCAL DISPLAY SETUP > DISPLAY HARDWARE INFORMATION). Note that the information in this menu may be useful during troubleshooting. The information here cannot be edited on this screen; however, some parameters are editable by the user on other screens.

This menu contains the following information:

- Display serial number.
- Software version.
- Display input voltage.
- SV-BAT-320 charge state.
- Operational state of the internal battery management circuitry.
- Operational state of the internal voltage rails.
- Screen brightness level.
- Local light sensor output.
- External light sensor output.
- Brightness level output.
- Contact input status.
- Serial port status and current baud rate.
- Button states.
- Operational hours.

29.8.1 Display Serial Number

The serial number of the display is noted here as SERIAL NUMBER: XXXXXX.

29.8.2 Display Software Version

The Software version of the display is noted here as SOFTWARE VERSION: X.X.XX.XXX.

29.8.3 Display Input Voltage

The display's input voltage is list here as VOLTAGE: XX.XXV.

29.8.4 SV-BAT-320 Charge State

If there is an SV-BAT-320 connected to the display, its voltage level is shown here as BATTERY STATUS: XX.XXV. The battery is fully charged at 12.25V. Charging a completely discharged battery may take up to 4 hours. To conserve your aircraft battery, the SV-BAT-320 is only charged with SkyView detects your alternator/generator to be online.

29.8.5 Operational State of the Internal Battery Management Circuitry

The operational state of the display's internal battery management circuitry is listed here. If there is an SV-BAT-320 connected to the display, you will see one (1) of the following states:

- CHARGING: SkyView system voltage is above 12.25V. SkyView is running on master power and is charging the SV-BAT-320.
- DISCHARGING: SkyView system voltage is below 10V. SkyView runs on the SV-BAT-320. The SV-BAT-320 discharges.
- CHARGED: SkyView system voltage is above 12.25V, and the SV-BAT-320 is fully charged.
- STANDBY: SkyView system voltage is above 10V, but below 12.25V: SkyView runs on master power but does not charge the SV-BAT-320. To conserve your aircraft battery, the SV-BAT-320 is only charged with SkyView detects your alternator/generator to be online.
- NO BATTERY: No SV-BAT-320 is connected.

29.8.6 Operational State of the Internal Voltages

There are several important voltages in the display. You will find their statuses here. If they are all operating at specified levels, then you will see OK. If any voltage is operating out of specification, you will see X.XV FAIL for that voltage.

29.8.7 Screen Brightness Level

The screen's brightness level is shown here as a percent. For example, 100.0 means 100% and 50.0 means 50%.

29.8.8 Local Light Sensor Output

Each SkyView display has an integrated light sensor on the front bezel and its output is shown here.

29.8.9 External Light Control Signal Output

SkyView displays are compatible with external light control signals. The state of the external light control signal is shown here.

29.8.10 Brightness Level Output

SkyView displays can output a brightness level signal to control the brightness of compatible external equipment screens. The level of the output is shown here.

29.8.11 Contact Input Status

Each SkyView display has four (4) contact inputs. The status of each contact input is shown here as either HIGH or LOW. CONTACT INPUT 1 is implemented as EXTERNAL LEVEL button. CONTACT INPUT 2 is implemented as EXTERNAL GO AROUND button. CONTACT INPUT 3 and CONTACT INPUT 4 have not been implemented.

29.8.12 Serial Port Status and Current Baud Rate

Each SkyView display has five (5) general purpose serial ports. The status of each serial port is shown with transmit (TX) and receive (RX) character counters and the ports current baud rate. The character counters show any outgoing or incoming character and roll over at 9999.

29.8.13 Button States

The state of each button is shown on the BUTTON STATE line. You will see 1 2 3 4 5 6 7 8 on the line. When you press a button, its respective number on the button state line is replaced with an asterisk (*). For example, if you press and hold button 3, you will see 1 2 * 4 5 6 7 8.

29.8.14 Operational Hours

This is a running count of the hours a screen has been on since was initially manufactured.

29.9 Instructions for Continued Airworthiness

Instructions for Continued Airworthiness (ICA) for the SkyView HDX system are provided in the *SkyView HDX General Maintenance Manual* document.

29.10 Troubleshooting

The Display Hardware Information Page (SETUP MENU > LOCAL DISPLAY SETUP > DISPLAY HARDWARE INFORMATION) can be a valuable resource when troubleshooting SkyView and is described in the previous section.



If the suggestions below do not help, or your issue is not listed below, please contact Dynon Avionics Technical Support (contact information at the beginning of this manual).

29.10.1 Network Configuration or SkyView Network Module Does Not Work Properly

If you try to configure a SkyView network and it does not work, try the following:

- Check network wiring and try again. There may be a short or an open somewhere.
- Unplug network modules one (1) by one (1) and try again. It is possible that one (1) of the modules could cause the network to stop functioning.
- Try again.
- For modules such as the SV-ADAHRS-200, the SV-EMS-220, and SV-ARINC-429, observe the red LED light near the SkyView Network connector:
 - Flashing Fast: The module is operating normally and is configured and communicating on a SkyView Network.
 - Flashing Slowly: The module is operating normally but is not active on SkyView Network.
 - Off: The module is not receiving power (from a SkyView Network / Display)
 - On Solid - the module is receiving power but is not operating normally.

29.10.2 SkyView Reports STANDBY NETWORK ERROR

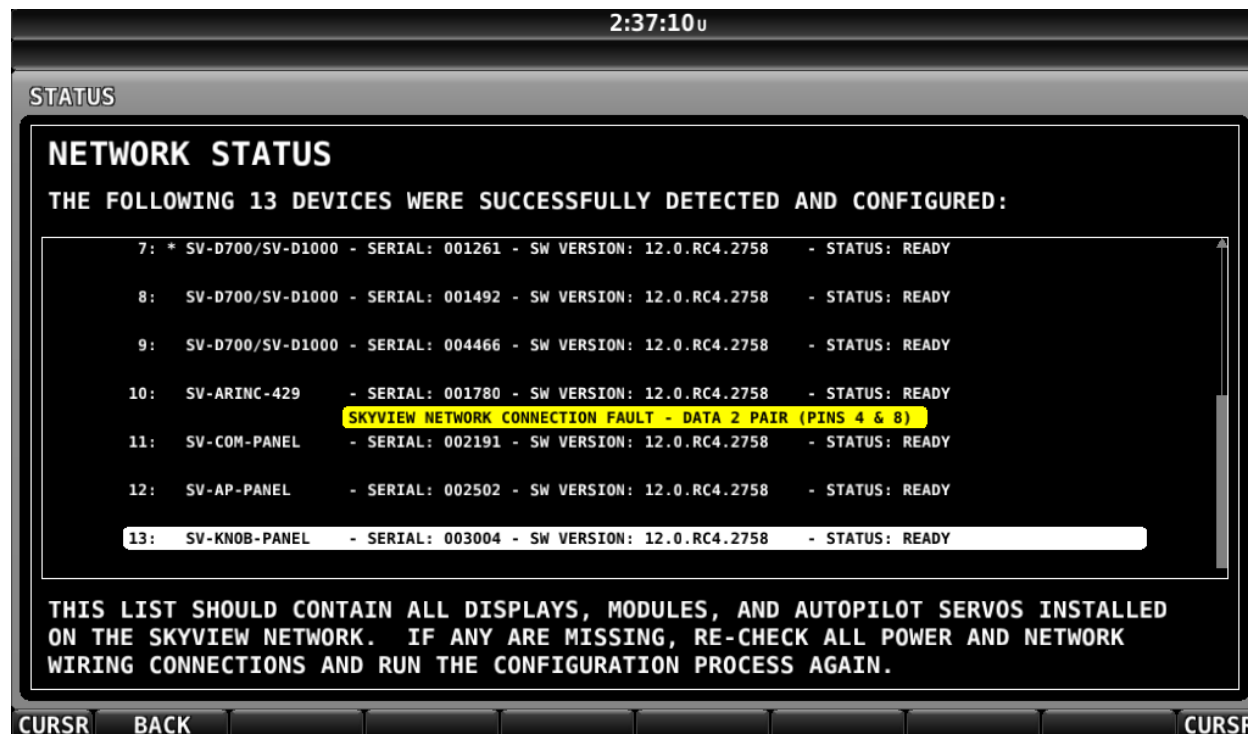

Figure 147: Troubleshooting STANDBY NETWORK ERROR message

SkyView has detected a problem with the SkyView Network wiring between one (1) or more modules. Go to SETUP MENU > SYSTEM SETUP > SKYVIEW NETWORK SETUP > NETWORK STATUS for a description of the problem. Module failures and/or wiring faults will be announced here to aid troubleshooting. The "PINS 4 & 8" or "PINS 1 & 6"

references the 9-pin connector of the SkyView Network cable. The fault will likely be listed below the component(s) that SkyView can see the fault in. This may help you narrow down the wiring run or connector that is faulty.

For example, a "SKYVIEW NETWORK CONNECTION FAULT – DATA 2 PAIR (PINS 4 AND 8)" listed below an SV-ADAHRS-200 listing in the network status page means that pins 4 and 8 on a SkyView Network harness or connector that goes to that component has a connectivity problem. This could be a broken wire, swapped wires, bad connection, etc., and should be analyzed with a multimeter or other direct method.

If the fault were instead listed under a SkyView display listing in the network status page, that means that the fault is seen on all devices connected to that display and is likely due to a connectivity issue at or very near the display in your SkyView Network wiring scheme.

29.10.3 Compass Calibration Fails

If you try to calibrate your compass and it does not work, try the following:

- Ensure SkyView is receiving data from the system's GPS receiver – a message: VALID GPS SIGNAL REQUIRED TO CALIBRATE COMPASS will appear if GPS data is not available.
- Ensure the SkyView network status includes the ADAHRS you're trying to calibrate. Use the Network Status Wizard and confirm that the ADAHRS is present in the system.
- Ensure the ADAHRS location is compatible with the requirements outlined in *Section 9 SV-ADAHRS-200 ADAHRS* of this manual, especially the discussion of external magnetic interference.

29.10.4 Display does not Turn On

If your SkyView display does not turn on, try the following:

- Check power wiring and fuses and try again. There may be a short or an open somewhere.
- Observe the lights on the Ethernet port. Unlike other Ethernet ports, these lights are used for display status:
 - Yellow light on: Power on pins 1/20 (power/ground).
 - Yellow light off: Display not receiving power.
 - Green light flashing: Normal when display is turned on or turned off with an SV-BAT-320 connected.
 - Green light solid on or off: Something is wrong with the SkyView display. Contact Dynon Avionics Technical Support (contact information at the beginning of this manual) for further support.

29.10.5 No GPS

GPS is an essential part of a SkyView system. If you do not have a working GPS, you cannot set the system time, calibrate the compass, or use the moving map. If you are experiencing these symptoms, try the following:

- If you have installed an SV-GPS-2020, its SERIAL IN FUNCTION must be set to POS 1.
- Check wiring and connections. Make sure all wiring runs are complete, that connections are solid, and that transmit (TX) and receive (RX) are not swapped. If you have more than one (1) SkyView display, make the same serial port connections to ALL SkyView displays. If you are using the SV-GPS-2020 GPS Receiver, make sure that power and ground wires are also installed correctly.
- Ensure that the GPS serial port's parameters are configured correctly. Go to the Serial Port Setup Menu (SETUP MENU > SYSTEM SETUP > SERIAL PORT SETUP > SERIAL PORT # SETUP) and check the input device, function, baud rate, and output device properties of the port. This menu also contains serial transmit (TX) and receive (RX) counters. These counters show activity on the transmit and receive lines of that serial port and can indicate if the GPS is active on that port. Reference the SV-GPS-2020 Electrical Installation Section for SV-GPS-2020 serial port settings. Also reference the RS-232 Serial Devices Section if a comprehensive explanation of SkyView serial connections is necessary.

29.10.6 Engine Sensor Does Not Show Up Onscreen

Make sure the sensor is installed, defined, mapped, and configured according to the instructions found in *Section 12 SV-EMS-220 Engine Monitoring System*.

30 Appendix B: Specifications

30.1 Minor Unit Physical Specifications

Table 57: SkyView Minor Equipment Weights

SkyView / Dynon Avionics Equipment Description	Approx. Weight
Ammeter Shunt	0.32 lb. (0.14 kg)
AOA/Pitot Probe, unheated	0.36 lb. (0.16 kg)
Antenna – 978 MHz (for ADS-B)	0.05 lb. (0.02 kg)
Antenna – 1090 MHz (for Transponder)	0.05 lb. (0.02 kg)
Carburetor Air Temperature Sensor	0.13 lb. (0.06 kg)
Capacitance to Voltage Converter (single)	0.08 lb. (0.04 kg)*
CHT Sensor (single)	0.08 lb. (0.04 kg)*
EGT Sensor (single)	0.09 lb. (0.04 kg)*
EMS 37-pin Main Sensor Harness	0.81 lb. (0.37 kg)
EMS EGT/CHT 4-cylinder 25-pin Thermocouple Wire Harness	0.71 lb. (0.32 kg)
EMS EGT/CHT 6-cylinder 25-pin Thermocouple Wire Harness	0.69 lb. (0.31 kg)
Fluid Pressure Sensor with pigtail	0.11 lb. (0.05 kg)*
Fuel Flow Transducer (single)	0.24 lb. (0.11 kg)*
Manifold Pressure Sensor	0.20 lb. (0.09 kg)
OAT Sensor	0.09 lb. (0.04 kg)
SV-ETHERNET-3CC	0.07 lb. (0.03 kg)
SV-HARNESS-D37	0.47 lb. (0.21 kg)
SV-NET-1.5CC	0.16 lb. (.071 kg)
SV-NET-3CC	0.21 lb. (0.10 kg)
SV-NET-6CC	0.33 lb. (0.15 kg)
SV-NET-10CP	0.49 lb. (0.22 kg)
SV-NET-15CP	0.68 lb. (0.31 kg)
SV-NET-20CP	0.87 lb. (0.40 kg)
SV-NET-25CP	1.07 lb. (0.49 kg)
SV-NET-30CP	1.26 lb. (0.57 kg)
SV-NET-HUB	0.19 lb. (0.09 kg)
SV-NET-SERVO	0.70 lb. (0.32 kg)
SV-NET-SPL	0.20 lb. (0.09 kg)

Single sensor / accessory. Multiply by the number for total weight of sensors / accessories.

30.2 SkyView Compatible Engine Sensors (sold by Dynon Avionics)

Table 58: SkyView Compatible Engine Sensors

Description	Range/Type	Fittings	Dynon Avionics P/N
Amps Shunt or Ammeter Shunt	0-100 A (can be configured to display 0 A to 100 A)	2 each 1/4" Ring Terminals	503386-000
Carburetor Air Temperature	-50° F to 150° F	1/4-28 UNF	503416-000
CHT (for Lycoming/Continental/Superior)	J-Type Thermocouple	Bayonet 3/8-24 UNF	503382-000
EGT (for Lycoming/Continental/Superior)	K-Type Thermocouple	1/8" hole, Hose Clamp, 1" – 2"	503384-000
EGT (for Rotax)	K-Type Thermocouple	1/8" hole, Hose Clamp 1/4" – 1 1/4"	503384-000
Fuel Flow Sensor	0.6 GPH -70+ GPH	1/4" Female NPT	503380-000
Fuel Pressure	0-15 PSI	1/8-27 NPT	505521-000
	0-50 PSI	1/8-27 NPT	505521-001
	0-150 PSI	1/8-27 NPT	505521-002
Manifold Pressure (MAP)	0-60 inHG	1/8-27 NPT	505522-000
OAT Sensor	-40° F to 150° F	3/8" hole in fuselage, 9/16" nut	503291-000
Oil Pressure	0-150 PSI	1/8-27 NPT	505521-002
Oil Temperature (for Lycoming/Continental/Superior)	-10° F to 300° F	5/8-18 UNF	503385-000
Oil Temperature (for older Continental 0-200s)	-10° F to 300° F	1/8-27 NPT	503807-000

30.3 SV-BAT-320 Specifications

Table 59: SV-BAT-320 Specifications

Specification	Parameter	Notes
Cell generic description	Li-Ion 18650	
Cell chemistry	Li-Ion	Lithium-Ion
Cell Voltage	3.7V	Total pack: 11.1V
Cell Current	2200 mAh	Total pack: 4400 mAh
Number of cells	6	2 cells in parallel, x3 in series
Protection from over-charge?	Yes	Integrated protection circuit
Protection from over-discharge?	Yes	
Protection from short circuit?	Yes	
Protection from over-current?	Yes	
Safe to be shipped? Air – IATA Sea – IMDG Road – ADR Rail – RID	Yes	SV-BAT-320 has minimal lithium content, below threshold(s) considered to be dangerous.

30.4 SV-XPNDR-261 Specifications

Table 60: SV-XPNDR-261 Specifications

Specification	Characteristics
Compliance	ETSO 2C112b Class 1 Level 2els (see below), ETSO C166a Class B0, TSO C112c Class 1 Level 2els (see below), TSO C166b Class B1S
	Level 2 (Comm B) Level 1 + receive and transmit 112 Bit Messages Level 2A Same as Level 2 without the support air-initiated Comm B messages
	e – Extended squitter, the ability to send ADS-B/1090ES data. This requires an external GPS (certified GPS units only). Mode S transponders with 1090ES capability can always send ADS-B data out but may not be able to receive ADS-B data in to receive traffic information. The actual data out and data-in capabilities for each model are shown out in the table above.
	I – Elementary surveillance, i.e. basic position reporting derived from SSR radar, enhanced in the case of a Mode S environment with higher resolution (25') pressure altitude, unique ICAO aircraft ID and other Mode S capabilities. Note that this is different than 1090ES/ADS-B data-out capabilities.
	S – Surveillance Identifier (SI) code. Used by Mode S transponders and Mode S equipped SSR to limit interrogations to specific transponders.
FCC Identification	VZI00745
Applicable documents	EUROCAE ED-73C, EUROCAE ED-14F (RTCA DO-160F), RTCA DO-181D, RTCA DO-260B
Software	ED-12B (RTCA DO-178B) Level B
Hardware	DO-254 Level C
Power Requirements	11 – 33 Volts DC. Typical 6 Watts @ 14Volts.
Altitude	35,000 feet
Humidity	95% @ +50°C for 6 hours; 85% @ +38°C for 16 hours. Tested to Category A in DO-160F
Operating Temperature	-20°C to +70°C
Transmitter Frequency	1090MHz ± 1MHz
Transmitter Power	250 Watts nominal; 125 Watts minimum at antenna after allowing for 0.5dB connector losses and 1.5dB cable losses.
Transmitter Modulation	6M75 V1D
Receiver Frequency	1030 MHz
Receiver Sensitivity	-74Dbm ± 3Db
Physical Specifications (in the mounting tray)	
Height	48mm (1.9")
Width	66mm (2.5")
Length	160mm (6.3")
Weight	0.77lbs. (350 g)

30.5 SV-XPNDR-261 ADS-B Information

SV-XPNDR-261 transponder modules include support for Extended Squitter ADS-B out. The SV-XPNDR-261 with SV-XPNDR Software 2.02 or higher is a DO-260B compliant broadcast participant.

30.6 ADS-B Parameters Supported

The following table lists the ADS-B parameters that are transmitted by the SV-XPNDR-261 transponder when connected to an appropriate GPS receiver.

Table 61: SV-XPNDR-261 ADS-B Parameters Supported

Parameter		BDS Register
SPI		0,5
Emergency Indicator		0,5
Barometric Altitude		0,5
Quality Indicator (NIC)		0,5
Airborne Position	Latitude	0,5
	Longitude	0,5
Quality Indicator (NIC)		0,6
Surface Position	Latitude	0,6
	Longitude	0,6
Surface Ground Speed		0,6
Surface Ground Track		0,6
Aircraft Identification		0,8
Airborne Ground Velocity		0,9
Geometric to Barometric altitude difference		0,9
Geometric Vertical Rate		0,9
Squawk Code		6,1
Emergency Status		6,1
Quality Indicator (NACp)		6,5
Quality Indicator (NACv)		6,5
Quality Indicator (SIL)		6,5
Version Indicator		6,5
Surface Length/Width		6,5
Surface Antenna Offset		6,5

In all cases, uncompensated latency due to the transponder is less than 10 milliseconds. Analysis of the system latency should add this to the latency of the GPS system and the transmission time of the position data from the GPS to the transponder to determine the overall latency.

30.6.1 14 CFR § 91.227 Compliance

The Dynon Avionics SV-XPNDR-261 transponder can be connected to the following GPS units to form the basis of a 14 CFR § 91.227 compliant ADS-B Out installation:

- Dynon Avionics SV-GPS-2020 (connected to SkyView display).
- Avidyne IFD440/IFD540 (connected directly).
- FreeFlight 1201/1204 (connected directly).
- Garmin GNS 400W/500W series (connected directly).
- Trig Avionics TN70 (connected directly).

For installations seeking certification to 14 CFR § 91.227 or other applicable standards, additional compliance information may be available on request from Dynon Avionics or Trig Avionics Limited.

30.6.2 AMC 20-24 Compliance

The Dynon Avionics SV-XPNDR-261 or Dynon Avionics SV-XPNDR-262 transponder can be connected to the following GPS units to form the basis of an AMC20-24 compliant ADS-B installation:

- Avidyne IFD440/IFD540 (connected directly).
- FreeFlight 1201/1204 (connected directly).
- Garmin GNS 400W/500W series (connected directly).
- Trig Avionics TN70 (connected directly).

For installations seeking certification to AMC 20-24 or other applicable standards, additional compliance information is available on request from Trig Avionics Limited.

30.6.3 Automatic Air/Ground Determination

The SV-XPNDR-261 can report ADS-B surface and airborne messages. This can be accomplished via a squat switch input that is designed to be used with an automatic air/ground switching device, or via automatic detection. These options are fully explained in section SV-XPNDR-261 Transponder of this manual.

30.7 SV-COM-T25 Specifications

Table 62: SV-COM-T25 Specifications

Specification	Characteristics
Compliance	ETSO 2C169a Class C, 4 ETSO 2C128 TSO C169a Class C, 4, TSO C128a
FCC Identification	VZI00882
Applicable documents	EUROCAE ED-23C EUROCAE ED-67 EUROCAE ED-14F (RTCA DO-160F) RTCA DO-186B RTCA DO-207
Software	ED-12B (RTCA DO-178B) Level B
Hardware	DO-254 Level C
Power Requirements	11 – 33 volts DC Typical 2.8 watts @ 14volts, receive Typical 28 watts @ 14 volts, transmit Maximum current 3.2A
Altitude	55,000 feet
Humidity	95% @ +50°C for 6 hours 85% @ +38°C for 16 hours Tested to Category A in DO-160F
Operating Temperature	-20°C to +70°C
Transmitter Frequency	118.000 MHz to 136.992 MHz 760 channels at 25 kHz spacing
Transmitter Power	6 Watts nominal carrier power
Transmitter Modulation	5K6 A3E
Stuck-mic timeout	35 seconds
Transmitter Duty Cycle	100% transmit is possible (subject to stuck mic timeout)
Receiver Frequency	118.000 MHz to 136.992 MHz 760 channels at 25 kHz spacing
Receiver Sensitivity	< 5uV for 6 dB SINAD
AGC Characteristic	< 6dB variation 5 μV to 100 mV EMF
Maximum VSWR	2.5:1 or lower
Physical Specifications (in the mounting tray)	
Height	Height 48mm (1.9")
Width	Width 66mm (2.5")
Length	Length 160mm (6.3")

30.8 SV-COM-T8 Specifications

Table 63: SV-COM-T8 Specifications

Specification	Characteristics
Compliance	ETSO 2C169a Class C, E, H1, H2, 4, 6 ETSO 2C128 TSO C169a Class C, E, 4, 6, TSO C128a
FCC Identification	VZI00882
Applicable documents	EUROCAE ED-23C EUROCAE ED-67 EUROCAE ED-14F (RTCA DO-160F) RTCA DO-186B RTCA DO-207
Software	ED-12B (RTCA DO-178B) Level B
Hardware	DO-254 Level C
Power Requirements	11 – 33 volts DC Typical 2.8 watts @ 14volts, receive Typical 28 watts @ 14 volts, transmit Maximum current 3.2A
Altitude	55,000 feet
Humidity	95% @ +50°C for 6 hours 85% @ +38°C for 16 hours Tested to Category A in DO-160F
Operating Temperature	-20°C to +70°C
Transmitter Frequency	118.000 MHz to 136.992 MHz 760 channels at 25 kHz spacing 2280 channels at 8.33 kHz spacing
Transmitter Power	6 Watts nominal carrier power
Transmitter Modulation	5K6 A3E
Stuck-mic timeout	35 seconds
Transmitter Duty Cycle	100% transmit is possible (subject to stuck mic timeout)
Receiver Frequency	118.000 MHz to 136.992 MHz 760 channels at 25 kHz spacing 2280 channels at 8.33 kHz spacing
Receiver Sensitivity	< 5uV for 6 dB SINAD
AGC Characteristic	< 6dB variation 5 μV to 100 mV EMF
Maximum VSWR	2.5:1 or lower
Physical Specifications (in the mounting tray)	
Height	Height 48mm (1.9")
Width	Width 66mm (2.5")
Length	Length 160mm (6.3")

30.9 SV-COM-T25/T8 Environmental Qualification Form

Table 64: SV-COM-T25/T8 Environmental Qualification Form

Conditions	DO-160F Section	Description of Conducted Tests
Nomenclature:	TY91 VHF radio	
P/Ns: 01857-00-03 (T25), 00882-00-01 (T8)	ETSO: 2C169a	
Manufacturer:	Trig Avionics Limited	
Address:	Heriot Watt Research Park, Riccarton, Edinburgh, Scotland, EH14 4AP	
Temperature and Altitude	4.0	Equipment tested to Categories A2, C1
Low temperature ground survival	4.5.1	-55°C
Low temperature short-time operating	4.5.1	-40°C
Low temperature operating	4.5.2	-20°C
High temperature operating	4.5.4	+70°C
High temperature short-time operating	4.5.3	+70°C
High temperature ground survival	4.5.3	+85°C
Loss of Cooling	4.5.5	Cooling air not required (+70°C operating without cooling air)
Altitude	4.6.1	55,000 feet
Decompression	4.6.2	8,000 to 55,000 feet in 15 seconds
Overpressure	4.6.3	-15,000 feet
Temperature Variation	5.0	Equipment tested to Category B
Humidity	6.0	Equipment tested to Category A
Operational Shocks	7.2	Equipment tested to Category B
Crash Safety	7.3	Equipment tested to Category B type 5
Vibration	8.0	Aircraft zone 2; type 3, 4, 5 to category S Level M, type 1 (Helicopters) to category U Level G
Explosion	9.0	Equipment identified as Category X – no test required
Waterproofness	10.0	Equipment identified as Category X – no test required
Fluids Susceptibility	11.0	Equipment identified as Category X – no test required
Sand and Dust	12.0	Equipment identified as Category X – no test required
Fungus	13.0	Equipment identified as Category X – no test required
Salt Spray	14.0	Equipment identified as Category X – no test required
Magnetic Effect	15.0	Equipment tested to Category Z, safe distance 1 meter
Power Input	16.0	Equipment tested to Category BX
Voltage Spike	17.0	Equipment tested to Category B
Audio frequency conducted susceptibility	18.0	Equipment tested to Category B
Induced signal susceptibility	19.0	Equipment tested to Category AC
Radio frequency susceptibility	20.0	Equipment tested to Category TT
Radio frequency emission	21.0	Equipment tested to Category B
Lightning induced transient susceptibility	22.0	Equipment tested to Category B2H2L2
Lightning direct effects	23.0	Equipment identified as Category X – no test required
Icing	24.0	Equipment identified as Category X – no test required
Electrostatic Discharge	25.0	Equipment identified as Category X – no test required
Fire, Flammability	26.0	Equipment identified as Category C

30.10 SV-GPS-2020 Specifications

Table 65: SV-GPS-2020 Specifications

Specification	Parameters
Description	WAAS GPS Receiver / Antenna
Compliance	Meets 14 CFR § 91.225, 14 CFR § 91.227, and performance requirements of TSO-c166b
Source Integrity Level (SIL)	3
System Design Assurance (SDA)	2
Update Rate	4 Hz
Receives WAAS Correction Signals (where available)	Yes
Uses all available positioning satellites?	No (L1 only)
Time to Acquire Fix (cold start)	60 Seconds
Data Interface	TX – Grey/Violet RS-232C @ 115,200 baud
	RX – Grey/Orange RS-232C (not currently implemented)
NMEA data sentences	GPGGA, GPGLL, GPGSA, GPGSV, GPRMC, GPVTG, GPZDA (additional proprietary data)
Transponder Compatibility	Dynon Avionics SV-XPNDR-261 (Minimum Software SW02.08)
System Compatibility	Dynon Avionics SkyView System Software: v14.0 +
Maximum Altitude	60,000 Feet (18,200 Meters)
Maximum Velocity	400 Knots (740.8 KPH)
Size	2.19 in. W x 0.75 in. H x 3.44 in. D (55.63mm W x 19.05mm H x 87.38mm D)
Weight	7 oz. (198g)
Power Requirements	8V, 0.1A (Orange Wire +)
	Electrical Ground (Black Wire -)
Operating Temperature	-4°F to +158°F (-20°C to +70°C)
Storage Temperature	-40°F to +140°F (-40°C to +60°C)

30.11 SV-AP-TRIMAMP Specifications

Table 66: SV-AP-TRIMAMP Specifications

Specification	Parameters
Description	Electric Trim Signal Amplifier
System Compatibility	Dynon Avionics SkyView System Software: v16.0 +
Size	3.77" W x 1.18" H x 3.56" D (96 mm W x 30 mm H x 90 mm D)
Weight	0.40 lb. (0.18 kg)
Input Voltage Range	10-30 Volt
Minimum Motor Current	0.05 Amps
Maximum Motor Current	3.00 Amps
Maximum Clutch Current	3.00 Amps
Maximum Total Current	5.00 Amps
Interrupt Input	Ground to disable
Operating Temperature	-22° F to 140° F (-30° C to +60° C)
Storage Temperature	-40° F to 158° F (-40° C to 70° C)

31 Appendix C: Wiring and Electrical Connections



SkyView utilizes standardized network connectors and wire harnesses for equipment-to-equipment connections as well as other connections. Installers should rarely have to build custom wire harnesses. This appendix is included as a reference for those rare times when custom wiring is required.

Improper wiring can result in permanent damage to your instrument and/or the accompanying sensors.

Make all connections to your harness before plugging it into any of the components of the system. Do not make connections while power is applied at any point in the system.

31.1 Wire Gauge

Unless otherwise specified, 22 AWG wire is normally sufficient for the power supply and ground lines, but we recommend that you consult a wire sizing chart to determine the size required for the wire routing in your particular aircraft. Ensure that the power lines include a circuit breaker or an appropriately sized fuse for the wire you select.

Smaller gauge wire is sufficient for lines that only carry data.

FAA Advisory Circular AC 43.13-1B is an excellent resource for wire sizing requirements as well as other acceptable methods, techniques, and practices in aircraft inspection and repair.

31.2 Grounding

Many of the engine sensors require a connection to a ground on the SV-EMS-220. There are many places on an aircraft where you could connect these sensors. However, the ideal location to ground these sensors is to one (1) of the SV-EMS-220 ground pins. Connecting the sensor's ground pin directly to the SV-EMS-220 minimizes any voltage difference between sensor ground and SV-EMS-220 ground.



You can measure the voltage difference between grounds to check if the connection has a minimal voltage drop. Set a multimeter to the DC voltages setting and place one (1) sensor tip on one (1) ground and place the other sensor tip on the other. Measurements close to 0 mV (within 5 mV) are, in most cases, acceptable.

Other grounding recommendations include:

- Ensure that solid, thick electrical connections exist between engine and battery ground.
- Do not paint over surfaces that are ground connection points.

31.3 DSUB Crimp Contacts and Tools

DSUB crimp contacts can be obtained from a variety of sources. Dynon Avionics recommends the use of the following Mil Spec types in avionics applications.

Table 67: Recommended DSUB Crimp Pins

Gender	Mil Spec #	Wire AWG
Female/Socket	M39029/63-368	20, 22, 24
Male/Pin	M39029/64-369	

Use a high quality 4-way indentation contact crimper when working the Mil Spec contacts in Table 67. Paladin Tools P/N 1440 (for 20 to 26 AWG wire) is an example of such a contact crimper tool.

31.4 Non-Dynon Avionics Wire Harness Considerations

It is recommended that the wire harness included with the SkyView display be used for connecting to power, serial ports, USB, the external battery, and other systems. However, if it is desired to fabricate a wire harness, it should be accomplished using materials and wire sizes in accordance with AC43.13-1B and AC43.13-2B.

SkyView Network cables use twisted data wire pairs for communication between devices. The wire pair should be twisted at 8-10 twists per foot over the entire length of the cable.

Pair #1:

Table 68: Pair #1

9-Pin Connector Pin #	Wire Color (Dynon Avionics Convention)	Signal Name
1	Green	Data 1A
6	Blue	Data 1B

Pair #2:

Table 69: Pair #2

9-Pin Connector Pin #	Wire Color (SkyView Convention)	Signal Name
4	White/Blue	Data 2B
8	White/Green	Data 2A

In SkyView Network cables, power distribution pairs are also twisted together.

Pair #3:

Table 70: Pair #3

9-Pin Connector Pin #	Wire Color (SkyView Convention)	Signal Name
2	Black	Ground 1
7	Red	Power 1

Pair #4:

Table 71: Pair #4

9-Pin Connector Pin #	Wire Color (SkyView Convention)	Signal Name
3	White/Black	Ground 2
9	White/Red	Power 2

Individual wire, not twisted with any other wire:

Table 72: Individual Wire

9-Pin Connector Pin #	Wire Color (SkyView Convention)	Signal Name
5	Orange	EMS Aux

This wire is currently used only for SV-EMS-220 modules, but future modules may also require this signal, so we recommend it be included if you are building your own SkyView Network cables.

31.4.1 Heat Shrink Bundling and Strain Relief

All wires should be bundled together with heat shrink and then strain relieved when exiting the connector shell or hood.

31.4.2 USB Cable (from D37 connector)

The USB cable used in the SV-HARNESS-D37 is a unique part made to Dynon Avionics' specifications for this application and is not sold separately. Attempting to terminate a typical USB cable to a "DSUB" connector causes the USB device to perform marginally (in our experience). For that reason, we recommend that a non-Dynon Avionics version of the SV-HARNESS-D37 to not include a USB cable. Instead, purchase USB extension cables to plug into the two (2) USB ports on the back of the SkyView display.

31.4.3 SV-BAT-320 Connection



For warranty replacement, an SV-BAT-320 that is received at Dynon Avionics with a different connector than the factory-installed connector is not be eligible for warranty replacement.

To connect a harness (equivalent to SV-HARNESS-D37) not manufactured by Dynon Avionics to an SV-BAT-320, the following specifications must be followed closely for the SV-BAT-320 to charge and work correctly:

Connector: Molex Micro-Fit (Digi-Key P/N WM1856-ND).

Pins: Molex Micro-Fit (Digi-Key P/N WM1841-ND).

Wire: 22 AWG Tefzel, NO MORE THAN 24" LONG; Red w/Yellow stripe: M22759/16-22-24; Black: M22759/16-22-0.

Table 73: SV-HARNESS-D37 wiring for SV-BAT-320 Connection Wiring

Function	SkyView D37 Connector Pin	Wire Color	Molex Connector Pin
Power	2	Red/Yellow	3
Ground	23	Black	1

Do not cut off the connector supplied on the SV-BAT-320; instead, assemble a mating connector as specified above.

31.5 SkyView Equipment Electrical Connections

SkyView displays have six (6) connectors on the back of the unit as illustrated in Figure 148:

- One (1) D37M for connection to the SkyView Display Harness (SV-HARNESS-D37).
- Two (2) D9M SkyView network connectors (SV-NET-xxxx).
- Two (2) Standard 4-pin USB 2.0 jacks for use with USB Series A plugs. Note that there is also a USB port on the SV-HARNESS-D37 for convenience.
- One (1) standard 8-pin RJ45 connector for use with twisted pair Category 5 Ethernet cable.

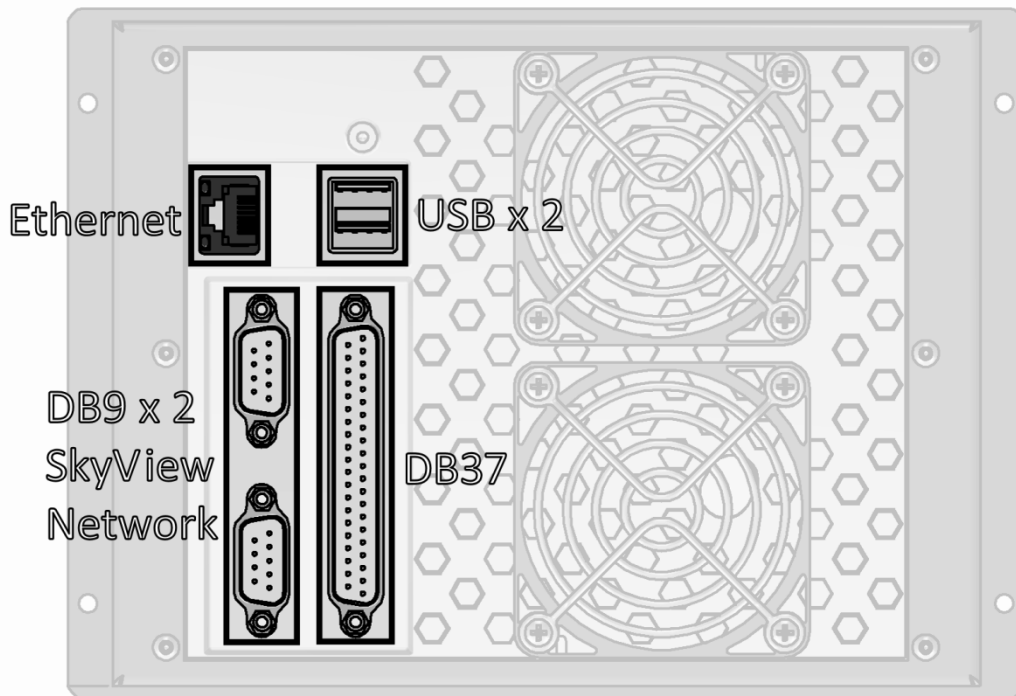

Figure 148: SkyView Display Connectors

A SkyView ADAHRS module (SV-ADAHRS-200/201) has two (2) connectors as illustrated in Figure 149:

- One (1) D9M SkyView network connector.
- One (1) 2-pin OAT sensor connector (only compatible with the SV-OAT-340).

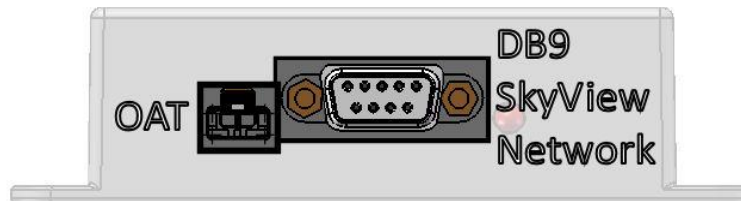

Figure 149: SV-ADAHRS-200/201 Connectors

The SkyView EMS Module (SV-EMS-220) has three (3) connectors as illustrated in Figure 150:

- One (1) D9M SkyView network connector.
- One (1) D37M for various transducer connections.
- One (1) D25F for thermocouple connections.

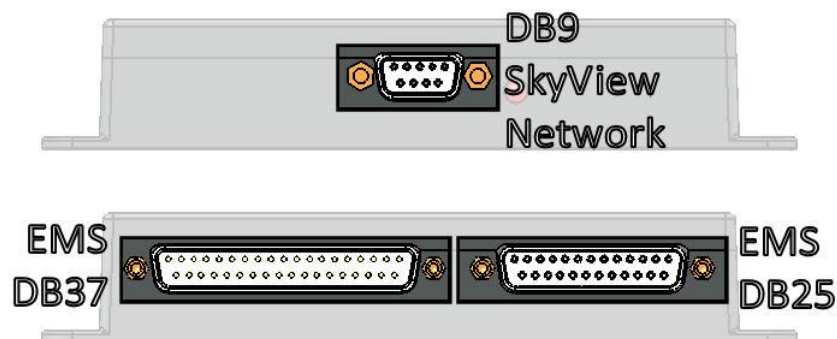

Figure 150: SV-EMS-220 Connectors

The SV-GPS-2020 receivers include four (4) unterminated wires. These wires may be trimmed or spliced and extended as needed to suit the installation location. Match the colors of these wires with the corresponding colors on the display harness as mentioned in the Electrical Installation Section of SV-GPS-2020 GPS Antenna/Receiver.

The SV-BAT-320 has one (1) connector. *Do not add more wire into the SV-BAT-320 wire bundle.*

Each SkyView servo has seven (7) unterminated wires. Reference *Section 18: Autopilot Servo* for more information.

31.6 SkyView Equipment Electrical Connector Pinout Tables

See tables on the follow pages for connector pin function descriptions. Tables for the USB jacks, RJ45 jack, OAT connector, and battery connector are not included.

31.6.1 Servo Pinout (SV-NET-SERVO)

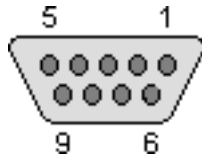

Figure 151: SV-NET-SERVO D9F Connector Pin Numbering

Dynon Avionics servos (SV32, SV42) use a D9M connector (included with the SV-NET-SERVO harness). Figure 151: SV-NET-SERVO D9F Connector Pin Numbering above shows the pin numbering for the servo's D9M connector, from the rear (pin insertion) view.

Table 74: SV-NET-SERVO Harness Pinout

SV-NET-SERVO Pin	SV-NET-SERVO Wire Color	Description
1	Green	SkyView Network Data 1A
2	Black	Aircraft Ground
3	Yellow	AP Disengage/Control Wheel Steering (CWS) Button
4	White/Blue	SkyView Network Data 2B
5	N/A	No connection
6	Blue	SkyView Network Data 1B
7	Red	Power (10 to 30 volts DC)
8	White/Green	SkyView Network Data 2A
9	N/A	No connection

31.6.2 SkyView Display D37 Pinout (SV-HARNESS-D37)

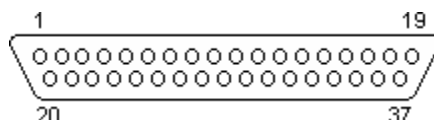

Figure 152: SkyView Display D37F Connector Pin Numbering

Dynon Avionics SkyView displays use a D37M connector for the majority of its connections. Figure 152: SkyView Display D37F Connector Pin Numbering above shows the pin numbering for the mating D37F connector, installed on the cable that plugs into this connector, from the rear (pin insertion) view. The SV-HARNESS-D37 is normally bundled with a SkyView display, though the SkyView display can be purchased without an SV-HARNESS-D37, and the SV-HARNESS-D37 can be purchased separately, for wiring the panel prior to purchasing a SkyView display.

The D9M connectors are SkyView Network connectors which are detailed in Table 76 below.

Table 75: SkyView Display D37M Pinout with Harness Wire Colors

SkyView Display D37M Pin	SV-HARNESS-D37 Wire Color	Description
1	Red	Power Input
2	Red with Yellow stripe	SV-BAT-320 +
3	Brown with Violet stripe	Serial Port 1 RX
4	Brown with Orange stripe	Serial Port 1 TX
5	Yellow with Violet stripe	Serial Port 2 RX
6	Yellow with Orange stripe	Serial Port 2 TX
7	Green with Violet stripe	Serial Port 3 RX
8	Green with Orange stripe	Serial Port 3 TX
9	Blue with Violet stripe	Serial Port 4 RX
10	Blue with Orange stripe	Serial Port 4 TX
11	Gray with Violet stripe	Serial Port 5 RX
12	Gray with Orange stripe	Serial Port 5 TX
13	Brown	Audio Output Left
14	Orange with Yellow stripe	Contact Input 3
15	Orange with Green stripe	Contact Input 4
16	Red	USB Power
17	Black	USB Ground
18	White	USB-
19	Green	USB+
20	Red	Power Input
21	Black	Ground
22	Black	Ground
23	Black	Ground
24	Black	Ground
25	Violet	Dim Input
26	White	Dim Output

SkyView Display D37M Pin	SV-HARNESS-D37 Wire Color	Description
27	Orange with Red stripe	Contact Input 2 (Optional) External GO AROUND Button
28	Orange with Black stripe	Contact Input 1 (Optional) External LEVEL Button
29	Orange	SV-GPS-2020 Power Output
30	Black	Audio Ground
31	Gray	Audio Output Right
32	Do Not Connect	Do Not Connect
33	Do Not Connect	Do Not Connect
34	Do Not Connect	Do Not Connect
35	Do Not Connect	Do Not Connect
36	Do Not Connect	Do Not Connect
37	Do Not Connect	Do Not Connect

31.6.3 SkyView D37M Block Diagram

Figure 153 below illustrates basic SkyView display D37 electrical connections.

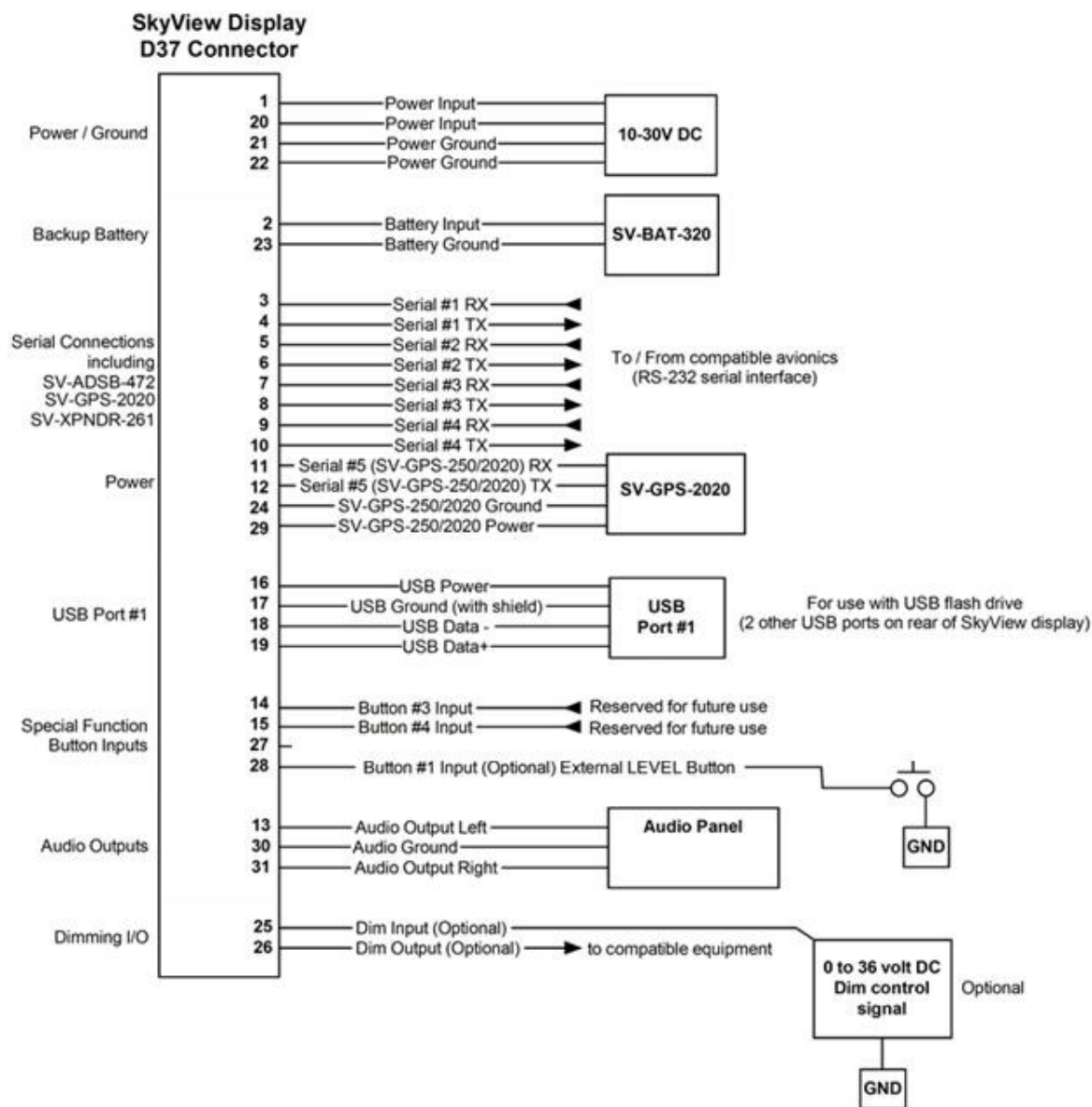

Figure 153: SkyView Display's D37M Connector Electrical Connections

31.6.4 SkyView Network Pinout (SV-NET-XXXX)

Table 76: SkyView Network D9M Pinout and Wire Harness Colors

SkyView Network D9M Pin	SkyView Network Cable Wire Color	Description
1	Green	SkyView Network Data 1 A
2	Black	SkyView Network Ground 1
3	White with Black Stripe	SkyView Network Ground 2
4	White with Blue Stripe	SkyView Network Data 2 B
5	Orange	SkyView EMS Auxiliary Voltage
6	Blue	SkyView Network Data 1 B
7	Red	SkyView Network Power 1
8	White with Green stripe	SkyView Network Data 2 A
9	White with Red stripe	SkyView Network Power 2

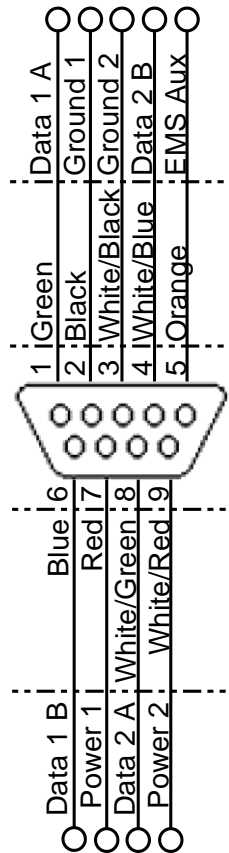

Figure 154: SkyView Network D9M Pin Insertion View (Rear)

31.6.5 SV-EMS-220 Pinouts (EMS Harnesses)

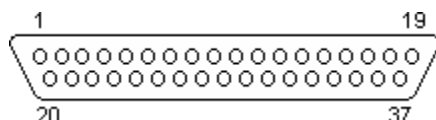

Figure 155: SV-EMS-220 D37F Connector Pin Numbering

The SV-EMS-220 uses a D37M connector for connecting most engine sensors. Figure 155 above shows the pin numbering for the mating D37F connector, installed on the cable that plugs into this connector, from the rear (pin insertion) view.

Table 77: SV-EMS-220 D37M Connector

SV-EMS-220 D37M Pin	EMS 37-pin Harness Wire Color	Description
1	Red	Voltmeter 1 (0 to 30 volts DC)
2	Yellow or Unwired	Voltmeter 2 (0 to 30 volts DC)
3	Black	Signal Ground
4	Violet/Blue	General Purpose Input 1
5	Black	Signal Ground
6	White/Yellow	General Purpose Input 11
7	White/Brown	General Purpose Input 12
8	Brown	Enhanced General Purpose Input 4
9	Brown/Blue	General Purpose Input 5
10	Brown/Yellow	General Purpose Input 6
11	Orange	General Purpose Input 7
12	Yellow	General Purpose Input 8
13	Black	Signal Ground
14	Yellow	Fuel Flow Input 1
15	Red	+12 volts DC Auxiliary Power Output
16	Black	Signal Ground
17	Black	Signal Ground
18	White/Red	+5 volts DC Auxiliary Power Output (Limited to 300 mA by internal self-resetting fuse)
19	White/Black	Fuel Flow Input 2
20	Orange/Brown	General Purpose Input 9
21	Orange/Blue	General Purpose Input 10
22	Violet/Yellow	Enhanced General Purpose Input 2
23	Violet/Green	Enhanced General Purpose Input 3
24	Orange/Green	Amps+ Input
25	Orange/Violet	Amps- Input
26	Green/Red	Manifold Pressure Input
27	Open	General Purpose Thermocouple Input 1+
28	Open	General Purpose Thermocouple Input 1-
29	Yellow/Green	No Connection
30	Black	Signal Ground
31	White/Orange	Enhanced General Purpose Input 13

SV-EMS-220 D37M Pin	EMS 37-pin Harness Wire Color	Description
32	White/Green	Standard RPM Left Input
33	White/Blue	Standard RPM Right Input
34	Blue	Low Voltage RPM Left Input
35	Green	Low Voltage RPM Right Input
36	Blue	General Purpose TC Input 2+
37	Green	General Purpose TC Input 2-

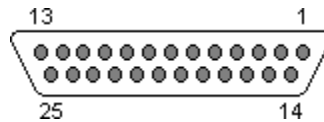

Figure 156: SV-EMS-220 D25M Connector Pin Numbering

The SV-EMS-220 uses a D25F connector for connecting most CHT/EGT (thermocouple) sensors. Figure 156 above shows the pin numbering for the mating D25M connector, installed on the cable that plugs into this connector, from the rear (pin insertion) view.

Table 78: SV-EMS-220 D25F Thermocouple Connector

SV-EMS-220 D25F Thermocouple Connector Pin	EMS 25-pin Thermocouple Harness Wire Color*	Description
1	Do Not Connect	Do Not Connect
2	Red	CHT6 RED
3	Red	EGT6 RED
4	Red	CHT5 RED
5	Red	EGT5 RED
6	Red	CHT4 RED
7	Red	EGT4 RED
8	Red	CHT3 RED
9	Red	EGT3 RED
10	Red	CHT2 RED
11	Red	EGT2 RED
12	Red	CHT1 RED
13	Red	EGT1 RED
14	White	CHT6 WHITE
15	Yellow	EGT6 YELLOW
16	White	CHT5 WHITE
17	Yellow	EGT5 YELLOW
18	White	CHT4 WHITE
19	Yellow	EGT4 YELLOW
20	White	CHT3 WHITE
21	Yellow	EGT3 YELLOW
22	White	CHT2 WHITE
23	Yellow	EGT2 YELLOW
24	White	CHT1 WHITE
25	Yellow	EGT1 YELLOW

*Note: this is the 6-cylinder CHT/EGT harness.

31.6.6 SV-ARINC-429 Pinout

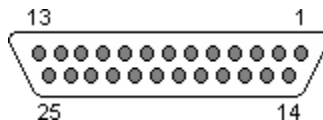

Figure 157: SV-ARINC-429 D25M Connector Pin Numbering

The SV-ARINC-429 uses a D25F connector for connecting to ARINC-429 devices. Figure 157 above shows the pin numbering for the mating D25M connector, installed on the cable that plugs into this connector, from the rear (pin insertion) view.

Table 79: SV-ARINC-429 D25F Connector

Pin	Wire Color	Function	Notes
1	N/A	No Connect	-
2	N/A	No Connect	-
3	(determined by installer)	Serial RX	Aviation Format Only from Connected ARINC-429 GPS
4	N/A	No Connect	-
5	N/A	No Connect	-
6	N/A	No Connect	-
7	N/A	No Connect	-
8	N/A	No Connect	-
9	N/A	No Connect	-
10	(determined by installer)	ARINC 2 RX B	-
11	(determined by installer)	ARINC 1 RX B	-
12	(determined by installer)	ARINC TX B	Pins 12/13 are the same TX signal. Provided for convenience when connecting multiple ARINC receivers.
13	(determined by installer)	ARINC TX B	Pins 12/13 are the same TX signal. Provided for convenience when connecting multiple ARINC receivers.
14	N/A	No Connect	-
15	N/A	No Connect	-
16	N/A	No Connect	-
17	N/A	No Connect	-
18	N/A	No Connect	-
19	N/A	No Connect	-
20	Black	Ground	-
21	N/A	No Connect	-
22	(determined by installer)	ARINC 2 RX A	-
23	(determined by installer)	ARINC 1 RX A	-
24	(determined by installer)	ARINC TX A	Pins 24/25 are the same TX signal. Provided for convenience when connecting multiple ARINC receivers.

25	(determined by installer)	ARINC TX A	Pins 24/25 are the same TX signal. Provided for convenience when connecting multiple ARINC receivers.
----	---------------------------	------------	-------------------------------------------------------------------------------------------------------

31.6.7 SV-ADSB-472 Pinout (SV-HARNESS-ADSB)

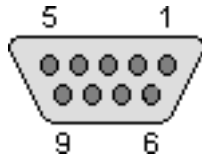

Figure 158: SV-ADSB-472 D9M Connector Pin Numbering

The SV-ADSB-472 uses a D9F connector (included with the SV-NET-ADSB harness). Figure 158 above shows pin numbering for the mating D9M connector, installed on the SV-HARNESS-ADSB, from the rear (pin insertion) view.

Note – this connector is NOT a SkyView Network Connector.

Table 80: SV-ADSB-472 D9F Pinout

Pin	SV-ADS-B 472 Wire Color	Function	Notes
1	Red	10-30V DC	Connect to Aircraft Power
2	Orange	SV-ADSB-472 Serial RX	Data Input from SkyView
3	Violet	SV-ADSB-472 Serial TX	Data Output to SkyView
4	Black	Ground	Connect to Aircraft Ground
5	N/A	No Connect	-
6	N/A	No Connect	-
7	N/A	No Connect	-
8	N/A	No Connect	-
9	N/A	No Connect	-

31.6.8 SV-XPNDR-261 Pinout (SV-HARNESS-XPNDR)

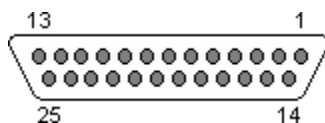

Figure 159: SV-XPNDR-261 D25M Connector Pin Numbering

The SV-XPNDR-261 uses a D25F connector (included with the SV-HARNESS-XPNDR harness). Figure 159 above shows pin numbering for the mating D25M connector, installed on the SV-HARNESS-XPNDR, from the rear (pin insertion) view.

Table 81: SV-XPNDR-261 D25 Pin

SV-XPNDR-261 D25 Pin	SV-HARNESS-XPNDR Wire Color	Function	Description
1	White	Loopback 1	Connect to Pin 2
2	White	Loopback 1	Connect to Pin 1
3	White	GPS Serial Input	Aviation Format Only
4	N/A	No Connect	-
5	Orange	SV-XPNDR-261 Serial RX	Connect to Pin 4, 6, 8, or 10 on SkyView Display D37 connector
6	N/A	No Connect	-
7	Violet	SV-XPNDR-261 Serial TX	Connect to Pin 3, 5, 7, or 9 on SkyView Display D37 connector
8	N/A	No Connect	-
9	N/A	No Connect	-
10	N/A	No Connect	-
11	N/A	No Connect	-
12	White	Loopback 2	Connect to Pin 13
13	White	Loopback 2	Connect to Pin 12
14	Black	Ground	Connect to Aircraft Ground
15	Red	11-33V DC	Connect to Aircraft Power
16	N/A	No Connect	-
17	N/A	External Standby In	Optional: Not Commonly Connected
18	N/A	Mutual Suppression	Optional: Not Commonly Connected
19	Yellow	Squat Switch In	Optional: Not Commonly Connected
20	Green	Ident Switch In	Optional: Not Commonly Connected
21	N/A	No Connect	-
22	N/A	No Connect	-
23	N/A	No Connect	-
24	N/A	No Connect	-
25	N/A	No Connect	-

31.6.9 SV-AP-PANEL Pinout (D15 connector)

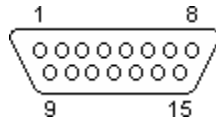

Figure 160: SV-AP-PANEL D15F Connector Pin Numbering

The SV-AP-PANEL Trim Control Subsystem uses a D15M connector for connecting to trim control buttons, the trim servo(s), and power for the trim servos(s). Figure 160 above shows the pin numbering for the mating D15F connector, installed on the cable that plugs into this connector, from the rear (pin insertion) view.

Table 82: SV-AP-PANEL D15M Connector

Pin	Wire Color	Function	Notes
1	N/A	N/A	No connection
2	Installer determined (use Black)	GROUND	Pin 5 on SV-AP-TRIMAMP harness
3	Installer determined	PILOT TRIM UP	Pilot Trim Switch Up Pin 7 polarity is + Pin 8 polarity is -
4	Installer determined	PILOT TRIM DOWN	Pilot Trim Switch Down Pin 7 polarity is – Pin 8 polarity is +
5	Installer determined	COPILOT TRIM UP	Co-pilot Trim Switch Up Pin 7 polarity is + Pin 8 polarity is -
6	Installer determined	COPILOT TRIM DOWN	Co-pilot Trim Switch down Pin 7 polarity is – Pin 8 polarity is +
7	Installer determined	MOTOR 1 A	Pin 4 on SV-AP-TRIMAMP harness
8	Installer determined	MOTOR 1 B	Pin 3 on SV-AP-TRIMAMP harness
9	Installer determined (use Red)	12 Volts @ 4A	Pin 9 on SV-AP-TRIMAMP harness
10	N/A	PILOT TRIM RIGHT	No connection
11	N/A	PILOT TRIM LEFT	No connection
12	N/A	COPILOT TRIM RIGHT	No connection
13	N/A	COPILOT TRIM LEFT	No connection
14	N/A	MOTOR 2 WIRE #1	No connection
15	N/A	MOTOR 2 WIRE #2	No connection

31.6.10 SV-COM-PANEL Pinout (D15 Connector)

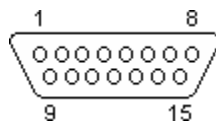

Figure 161: SV-COM-PANEL D15F Connector Pin Numbering

The SV-COM-PANEL uses a D15M connector for connecting to the SV-COM-T25/T8 COM radio module. Figure 161 above shows the pin numbering for the mating D15F connector, installed on the cable that plugs into this connector, from the rear (pin insertion) view.

Table 83: SV-COM-PANEL D15M Connector

Pin	Wire Color	Function	Notes
1	(determined by installer)	Power In	From 10-30V DC @ 5A (SV-COM-T25/T8)
2	(determined by installer)	Ground In	From Ground (SV-COM-T25/T8)
3	(determined by installer)	Ground Out	Optional – for Grounding Pin 7 (Flip/Flop Switch). Switch may also be grounded locally.
4	(determined by installer)	Panel RX	From SV-COM-T25/T8 Pin 6
5	(determined by installer)	PANEL TX	From SV-COM-T25/T8 Pin 5
6	(determined by installer)	Enable	From SV-COM-T25/T8 Pin 13
7	(determined by installer)	External Flip/Flop Switch (optional)	Push Button Normally Open to Ground (Pin 3 or Local Ground)
8	N/A	No Connect	-
9	N/A	No Connect	-
10	N/A	No Connect	-
11	N/A	No Connect	-
12	N/A	No Connect	-
13	N/A	No Connect	-
14	N/A	No Connect	-
15	N/A	No Connect	-

31.6.11 SV-COM-T25/T8 Pinout (D15 Connector)

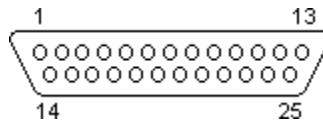

Figure 162: SV-COM-T25/T8 D25F Connector Pin Numbering

The SV-COM-T25/T8 uses a D25M connector for connecting to the SV-COM-PANEL. Figure 162 above shows the pin numbering for the mating D25F connector, installed on the cable that plugs into this connector, from the rear (pin insertion) view.

Table 84: SV-COM-T25/T8 D25M Connector

Pin	Wire Color	Function	Notes
1	(determined by installer)	PHONES GROUND	
2	(determined by installer)	PHONES OUT	
3	N/A	No Connection	-
4	N/A	No Connection	-
5	(determined by installer)	DATA RX FROM SV-COM-PANEL	Connect to SV-COM-PANEL Pin 5
6	(determined by installer)	DATA TX TO SV-COM-PANEL	Connect to SV-COM-PANEL Pin 4
7	N/A	No Connection	-
8	N/A	No Connection	-
9	(determined by installer)	MICROPHONE / PTT GROUND	
10	(determined by installer)	GROUND	No connection
11	N/A	No Connection	-
12	N/A	No Connection	-
13	(determined by installer)	SV-COM-PANEL ENABLE	Connect to SV-COM-PANEL Pin 6
14	N/A	No Connection	-
15	(determined by installer)	PTT IN	
16	N/A	No Connection	-
17	N/A	No Connection	-
18	(determined by installer)	TRANSMIT INTERLOCK	(Use only when there are two SV-COM-X25/X83s installed.) Connect to other radio's PTT.
19	(determined by installer)	GROUND IN	GROUND
20	N/A	No Connection	-
21	N/A	No Connection	-
22	(determined by installer)	GROUND IN	GROUND
23	(determined by installer)	MICROPHONE IN	

Pin	Wire Color	Function	Notes
24	(determined by installer)	POWER IN	10-30V DC @ 5A
25	(determined by installer)	POWER IN	10-30V DC @ 5A

32 Appendix D: SV-EMS-220 Sensor Input Mapping Worksheet

Use this worksheet to record SV-EMS-220 sensor input mapping.

IMPORTANT INSTALLATION INFORMATION	
SV-EMS-220 S/N	
Installer	
Installation Completion Date	

Table 85: SV-EMS-220 Sensor Input Mapping Worksheet

Pin	Function	Sensor	Name
C37 P1			
C37 P2			
C37 P4			
C37 P6			
C37 P7			
C37 P8			
C37 P9			
C37 P10			
C37 P11			
C37 P12			
C37 P14			
C37 P19			
C37 P20			
C37 P21			
C37 P22			
C37 P23			
C37 P24/25			
C37 P26			
C37 P27/28			
C37 P31			
C37 P32/34			
C37 P33/35			
C37 P36/37			
C25 P2/14			
C25 P3/15			
C25 P4/16			

Pin	Function	Sensor	Name
C25 P5/17			
C25 P6/18			
C25 P7/19			
C25 P8/20			
C25 P9/21			
C25 P10/22			
C25 P11/23			
C25 P12/24			
C25 P13/25			

33 Appendix E: Serial Data Output

SkyView outputs various types of serial data for users who want real-time aircraft and engine performance data. SkyView can be configured to output serial data through one of five serial ports. All numbers are output in decimal except when identified in standard ASCII format (see Data Format sections of this appendix for more information).

Any one of SkyView's *unused* RS232 serial ports can be configured to output serial data.



In multi-display SkyView systems, serial transmission will continue uninterrupted if one SkyView display is still operational. SkyView only transmits from one display's serial ports in a multi-display system. SkyView manages which display is the "actual transmitter" automatically to avoid serial port conflicts. Therefore, for reliable serial reception in multi-display systems, a SkyView serial data output wire must be wired from each display, in parallel, to the external serial device that is being used to capture SkyView's serial data.

To configure a serial port for data output:

1. Navigate to SETUP MENU > SYSTEM SETUP > SERIAL PORT SETUP > SERIAL PORT # SETUP.
2. From SERIAL OUT DEVICE, select the type of data you want to log:
 - DYNON EMS
 - DYNON ADAHRS
 - DYNON SYSTEM
 - DYNON ADAHRS + SYSTEM
 - DYNON ADAHRS + EMS
 - DYNON ADAHRS + SYS + EMS
 - NMEA OUT (BASIC)
 - NMEA OUT (FULL)
3. From SERIAL OUT DEVICE, select a Baud rate.
4. Connect an external serial device such as a PC to SkyView serial port you just configured.
5. Make sure external serial device is configured to receive data in the following format:
 - Baud rate: same as SERIAL OUT DEVICE (see Step #3).
 - Data: 8 bit
 - Parity: none
 - Stop: 1 bit
 - Flow control: none

33.1 DYNON ADAHRS Serial Data Format

The following section details the format of DYNON ADAHRS serial output data:

Table 86: SkyView ADAHRS Serial Data Output Format

Position	Width	Name	Description
1	1	Start Character / Data Type	'!
2	1	Data Type	1 = ADAHRS data. Other Dynon Avionics formats look similar and may be interleaved. This bit tells you what kind of data will follow.
3	1	Data Version	Currently 1. This is the version of the data represented below and will change if there is a future version that changes data. Has not changed to date.
4	8	System Time	HHMMSSFF, current Zulu time according to SkyView's internal clock which is synchronized with GPS time if GPS is available. HH is the hour from 00 to 23. MM is the minute from 00 to 59. SS is the second from 00 to 59. HHMMSS are '-----' if GPS time has never been available. FF is the 1/16-second fraction counter from 00 to 15 and may skip digits if baud rate is too low to send data at 16Hz.
12	4	Pitch (deg)	+/- then 000 to 900, pitch up or down from level flight in degrees * 10 (900 = 90°), positive meaning the aircraft is pitched up. XXXX when not available.
16	5	Roll (deg)	+/- then 0000 to 1800, roll left or right from level flight in degrees * 10 (1800 = 180°), positive meaning the aircraft is banked right. XXXXX when not available.
21	3	Magnetic Heading (deg)	000 to 359 in degrees. XXX when not available.
24	4	Indicated Airspeed (knots)	0000 to 9999, indicated airspeed in units of knots * 10 (1234 = 123.4 knots). XXXX when not available.
28	6	Pressure Altitude (ft.)	+/- then 00000 to 99999, altitude in units of feet, at a Baro setting of 29.92" Hg, positive meaning altitude is above sea-level. XXXXXX when not available.
34	4	Turn Rate (deg/s)	+/- then 000 to 999, rate of yaw change in degrees/second * 10, positive meaning the aircraft is turning right. XXXX when not available.
38	3	Lateral Accel (g)	+/- then 00 to 99, lateral g's in units of g * 100 (99 = 0.99 g's), positive meaning the aircraft is experiencing leftward lateral acceleration (slip / skid ball is deflected to the right). XXX when not available.
41	3	Vertical Accel(g)	+/- then 00 to 99, vertical g's in units of g * 10 (99 = 9.9 g's), positive meaning the aircraft is experiencing upward vertical acceleration. XXX when not available.
44	2	Angle of Attack (%)	00 to 99, percentage of critical angle of attack. XX when not available.
46	4	Vertical Speed (ft./min)	+/- then 000 to 999, feet/minute / 10 (42 = 420 feet per minute), positive meaning the aircraft is climbing. XXX when not available.

Position	Width	Name	Description
50	3	OAT (deg C)	+/- then 00 to 99. Outside Air Temperature in Degrees C. XXX when not available.
53	4	True Airspeed (knots)	0000 to 9999, true airspeed in units of knots * 10 (1234 = 123.4 knots). XXXX when not available.
57	3	Barometer Setting (inHg)	000 to 400. Baro setting in inHg * 100, offset by 27.50 inHg. Total range is 27.50 inHg to 31.50 inHg. (242 = 29.92 inHg). XXX when not available.
60	6	Density Altitude (ft.)	+/- then 00000 to 99999, altitude in units of feet, positive meaning altitude is above sea-level. XXXXXX when not available.
66	3	Wind Direction (deg)	000 to 359. Wind direction in degrees magnetic. XXX if unknown.
69	2	Wind Speed (knots)	00 to 99. Wind Speed in Knots. XX if unknown.
71	2	Checksum	The 1 byte sum of all 70 preceding bytes. In ascii-hex format, so 3A = 0x3A
73	2	CR/LF	Carriage Return, Linefeed = 0x0D, 0x0A.

As an example, the following is one (1) line of DYNON ADAHRS serial output data:

```
!1121144703-014+00003310811+01736+003-03+1013-033+110831245+01650023176C
```

33.2 DYNON SYSTEM Serial Data Format

The following section details the format of DYNON SYSTEM serial output data:

Table 87: SkyView SYSTEM Serial Data Output Format

Position	Width	Name	Description
1	1	Start Character	'!
2	1	Data Type	2 = System Info. Other Dynon Avionics formats look similar, and may be interleaved, this bit indicates what kind of data will follow.
3	1	Data Version	Currently 2. This is the version of the data represented below and will change if there is a future version that changes data. Data version changed at SkyView Software v5.1.
4	8	System Time	HHMMSSFF, current Zulu time according to SkyView's internal clock which is synchronized with GPS time if GPS is available. HH is the hour from 00 to 23. MM is the minute from 00 to 59. SS is the second from 00 to 59. HHMMSS are '-----' if GPS time has never been available. FF is the 1/16-second fraction counter from 00 to 15 and may skip digits if baud rate is too low to send data at 16Hz.
12	3	Heading Bug (deg)	000 to 359 in degrees. XXX if heading bug is not displayed.
15	5	Altitude Bug (ft.)	+/- then 0000 to 9999, altitude in units of tens of feet (1234 = 12,340 ft.). XXXXX if altitude bug is not displayed.
20	4	Airspeed Bug (knots)	0000 to 9999, airspeed in units of knots * 10 (1234 = 123.4 knots). XXXX if airspeed bug is not displayed.

Position	Width	Name	Description
24	4	Vertical Speed Bug (ft./min)	+/- then 000 to 999, tens of feet/minute. (123 = 1230 ft./min), positive meaning climb. XXXX if vertical speed bug is not displayed.
28	3	Course (deg)	000 to 359 in degrees.
31	1	CDI Source Type	0-2. 0=GPS, 1=NAV, 2=LOC.
32	1	CDI Source Port	0-5. GPSX, NAVX, or LOCX.
33	2	CDI Scale (NM)	00-50. In tenths of NM, 50 = 5.0 NM. Output 'XX' when not in GPS mode as there is no scale in NAV or LOC
35	3	CDI Deflection (%)	+/- then 00 to 99 percent of deflection, + meaning deflected to right, 'XXX' w/o valid CDI.
38	3	Glideslope (%)	+/- then 00 to 99 percent of deflection, + meaning deflected upward, 'XXX' w/o valid GS.
41	1	AP Engaged	0-7. 0=Off, 1= roll only, 2=pitch only, 3= roll+pitch, 4=yaw, 5=roll+yaw, 6=pitch+yaw, 7=pitch+roll+yaw (yaw doesn't currently exist, but format supports it). Will read 0 all the time if no AP is installed.
42	1	AP Roll Mode	0-4. 0=Heading, 1=Track, 2=NAV, 3=GPS Steering. Always reads zero when AP roll not engaged.
43	1	UNUSED	Reserved for future usage. Always reads 'X'. Parsers should not read this value.
44	1	AP Pitch Mode	0. 0=Altitude. Always reads zero when AP pitch not engaged.
45	1	UNUSED	Reserved for future usage. Always reads 'X'. Parsers should not read this value.
46	3	AP Roll Force	+/- then 00 to 80. Raw force number from servo, + meaning that a force is being exerted in the right-wing-downward direction against the servo. 80 is theoretical maximum before slipping. Always reads zero when AP roll not engaged.
49	5	AP Roll Position (steps)	+/- then 0000 to 9999. Position of servo output shaft relative to that at power-on, in steps, + meaning in the right-wing-downward direction. 800 steps represent a full rotation of the output shaft. Outputs "XXXXX" when not available.
54	1	AP Roll Slip (bool)	0 or 1. 0 = No slipping on this servo. 1 = At least one (1) slip on this servo in the last 3 seconds. Always reads zero when AP roll not engaged.
55	3	AP Pitch Force	+/- then 00 to 80. Raw force number from servo, + meaning that a force is being exerted in the nose-upward direction against the servo. 80 is theoretical maximum before slipping. Always reads zero when AP pitch not engaged.
58	5	AP Pitch Position (steps)	+/- then 0000 to 9999. Position of servo output shaft relative to that at power-on, in steps, + meaning in the nose-upward direction. 800 steps represent a full rotation of the output shaft. Outputs "XXXXX" when not available.
63	1	AP Pitch Slip (bool)	0 or 1. 0 = No slipping on this servo. 1 = At least one (1) slip on this servo in the last 3 seconds. Always reads zero when AP pitch not engaged.

Position	Width	Name	Description
64	3	AP Yaw Force	+/- then 00 to 80. Raw force number from servo, + meaning that a force is being exerted in the rightward direction against the servo. 80 is theoretical maximum before slipping. Always reads zero when AP yaw not engaged.
67	5	AP Yaw Position	+/- then 0000 to 9999. Position of servo output shaft relative to that at power-on, in steps, + meaning in the rightward direction. 800 steps represent a full rotation of the output shaft. Outputs "XXXXX" when not available.
72	1	AP Yaw Slip (bool)	0 or 1. 0 = No slipping on this servo. 1 = At least one (1) slip on this servo in the last 3 seconds. Always reads zero when AP yaw not engaged.
73	1	Transponder Status	0-3. 0=SBY, 1=GND, 2=ON, 3=ALT.
74	1	Transponder Reply (bool)	0 or 1. 0 = No reply in last second, 1 = at least one (1) reply within last second.
75	1	Transponder Identing (bool)	0 or 1. 0 = not IDENT'ing, 1 = IDENT active, as reported by Transponder.
76	4	Transponder Code (octal)	0000-7777
80	10	UNUSED	Reserved for future usage. Always reads 'XXXXXXXXXX'. Parsers should not read this value.
90	2	Checksum	The 1 byte sum of all 73 preceding bytes. In ascii hex format, so 3A = 0x3A
92	2	CR/LF	Carriage Return, Linefeed = 0x0D, 0x0A.

As an example, the following is one (1) line of DYNON SYSTEM serial output data:

```
!2221144704359XXXXX1600+010XXX00XXXXXXXXXX00X0X+00-
99990+00+99990+00XXXXX00104543XXXXXXXXXXXX3A
```

33.3 DYNON EMS Serial Data Format

The following section details the format of EMS data output to the serial port:

Table 88: SkyView EMS Serial Output Format

Position	Width	Name	Pin	Description
1	1	Start Character		'!
2	1	Data Type		3 = EMS Data. Other Dynon Avionics formats look similar, and may be interleaved, this bit indicates what kind of data will follow.
3	1	Data Version		Currently 2. This is the version of the data represented below and will change if there is a future version that changes data. Data version changed at SkyView Software v5.1.
4	8	System Time		HHMMSSFF, current Zulu time according to SkyView's internal clock which is synchronized with GPS time if GPS is available. HH is the hour from 00 to 23. MM is the minute from 00 to 59. SS is the second from 00 to 59. HHMMSS are "-----" if GPS time has never been available. FF is the 1/16-second fraction counter from 00 to 15 and may skip digits if baud rate is too low to send data at 16Hz.
12	3	Oil Pressure (PSI)	Varies (see note 1)	000 to 999 or XXX. Oil pressure in PSI. There must be a pressure sensor named "OIL" for this to work. See note 2.
15	4	Oil Temp (deg C)	Varies (see note 1)	+/- then 000 to 999 or XXX. Oil temperature in C. There must be a temperature sensor named "OIL" for this to work. See note 2.
19	4	RPM L	C37 P32/34	0 to 9999. RPM from Left input.
23	4	RPM R	C37 P33/35	0 to 9999. RPM from Right input.
27	3	Manifold Pressure (inHg)	C37 P26	0 to 600. Manifold Pressure in 0.1 inHg. 299 = 29.9 inHg. There must be a pressure sensor named "MAP" for this to work. See note 2.
30	3	Fuel Flow 1 (gal/hr.)	C37 P14	000 to 999. Fuel flow in 1/10 th Gallons Per Hour. 086 = 8.6 GPH. See note 2.
33	3	Fuel Flow 2 (gal/hr.)	C37 P19	000 to 999. Fuel flow in 1/10 th Gallons Per Hour. 086 = 8.6 GPH. This is usually return flow. See note 2.
36	3	Fuel Pressure (PSI)	Varies	000 to 999 or XXX. Fuel pressure in 1/10 th PSI. 274 = 27.4 PSI. There must be a pressure sensor named "FUEL" for this to work. See note 2.
39	3	Fuel Level L (gal)	Varies	000 to 999 or XXX. Fuel level in 1/10 th Gallons. 128 = 12.8 Gallons. There must be a Level sensor named "LEFT" for this to work. If there is no "LEFT" OR "RIGHT" but there is a "MAIN", this will be MAIN. See note 2.

Position	Width	Name	Pin	Description
42	3	Fuel Level R (gal)	Varies	000 to 999 or XXX. Fuel level in 1/10 th Gallons. 128 = 12.8 Gallons. There must be a Level sensor named "RIGHT" for this to work. See note 2.
45	3	Fuel Remaining (gal)	Fuel Computer	000 to 999 or XXX. Fuel level in 1/10 th Gallons. This is derived from the fuel computer and is based on the fuel on board added set by the user and the decremented by fuel flow. See note 2.
48	3	Volts 1	C37 P1	000 to 360 in 1/10 th Volts. 284 = 28.4 volts. See note 2.
51	3	Volts 2	C37 P2	000 to 360 in 1/10 th Volts. 284 = 28.4 volts. See note 2.
54	4	Amps	C37 P24/25	+/- then 000 to 999. 1/10 th Amps. -083 = -8.3A. See note 2.
58	5	Hobbs Time	Calculated	00000 to 99999. In 1/10 hours. 12345 = 1234.5 hours.
63	5	Tach Time	Calculated	00000 to 99999. In 1/10 hours. 12345 = 1234.5 hours.
68	4	Thermocouple 1 (deg C)	C25 P2/14	+/- then 000 to 999. In degrees C. See note 2.
72	4	Thermocouple 2 (deg C)	C25 P3/15	+/- then 000 to 999. In degrees C. See note 2.
76	4	Thermocouple 3 (deg C)	C25 P4/16	+/- then 000 to 999. In degrees C. See note 2.
80	4	Thermocouple 4 (deg C)	C25 P5/17	+/- then 000 to 999. In degrees C. See note 2.
84	4	Thermocouple 5 (deg C)	C25 P6/18	+/- then 000 to 999. In degrees C. See note 2.
88	4	Thermocouple 6 (deg C)	C25 P7/19	+/- then 000 to 999. In degrees C. See note 2.
92	4	Thermocouple 7 (deg C)	C25 P8/20	+/- then 000 to 999. In degrees C. See note 2.
96	4	Thermocouple 8 (deg C)	C25 P9/21	+/- then 000 to 999. In degrees C. See note 2.
100	4	Thermocouple 9 (deg C)	C25 P10/22	+/- then 000 to 999. In degrees C. See note 2.
104	4	Thermocouple 10 (deg C)	C25 P11/23	+/- then 000 to 999. In degrees C. See note 2.
108	4	Thermocouple 11 (deg C)	C25 P12/24	+/- then 000 to 999. In degrees C. See note 2.
112	4	Thermocouple 12 (deg C)	C25 P13/25	+/- then 000 to 999. In degrees C. See note 2.
116	4	Thermocouple 13 (deg C)	C37 P27/28	+/- then 000 to 999. In degrees C. See note 2.
120	4	Thermocouple 14 (deg C)	C37 P36/37	+/- then 000 to 999. In degrees C. See note 2.
124	6	GP Input 1	C37 P4	+/- then 0000 to 9999, then units. See notes. Example: +1234C = 123.4 degrees C.

Position	Width	Name	Pin	Description
130	6	GP Input 2	C37 P22	+/- then 0000 to 9999, then units. +YYYYZ. See note 3.
136	6	GP Input 3	C37 P23	+/- then 0000 to 9999, then units. +YYYYZ. See note 3.
142	6	GP Input 4	C37 P8	+/- then 0000 to 9999, then units. +YYYYZ. See note 3.
148	6	GP Input 5	C37 P9	+/- then 0000 to 9999, then units. +YYYYZ. See note 3.
154	6	GP Input 6	C37 P10	+/- then 0000 to 9999, then units. +YYYYZ. See note 3.
160	6	GP Input 7	C37 P11	+/- then 0000 to 9999, then units. +YYYYZ. See note 3.
166	6	GP Input 8	C37 P12	+/- then 0000 to 9999, then units. +YYYYZ. See note 3.
172	6	GP Input 9	C37 P20	+/- then 0000 to 9999, then units. +YYYYZ. See note 3.
178	6	GP Input 10	C37 P21	+/- then 0000 to 9999, then units. +YYYYZ. See note 3.
184	6	GP Input 11	C37 P6	+/- then 0000 to 9999, then units. +YYYYZ. See note 3.
190	6	GP Input 12	C37 P7	+/- then 0000 to 9999, then units. +YYYYZ. See note 3.
196	6	GP Input 13	C37 P31	+/- then 0000 to 9999, then units. +YYYYZ. See note 3.
202	16	Contacts	Not used in SkyView	Z*16 (ZZZZZZZZZZZZZZZZ).
218	3	Percent Power		000 to 199 in percentage of engine reference power. XXX when not determined or invalid.
221	1	EGT Leaning State		The state of EGT leaning. L: Lean of peak, P: Peak, R: Rich of peak. X when not determined or invalid.
222	2	Checksum		The 1 byte sum of all 217 preceding bytes. In ascii hex format, so 3A = 0x3A.
224	2	CR/LF		Carriage Return, Linefeed = 0x0D, 0x0A.

Note 1: These sensors can be connected to various pins on the EMS D37M connector. See the SkyView Installation Manual for more information.

Note 2: If the value is invalid, or out of range for the sensor, or the sensor is not configured, or if the sensor is configured but not calibrated, then an 'X' is output for each character in the field instead of a value.

Note 3: Units for each GP input depends on the type of sensor that is connected to the pin. See GP Inputs below.

Rotax 912 iS Note: When the engine type is 912iS, the following fields in the serial output source their data from the 912 iS' computer instead of conventional sensors: Oil Pressure, Oil Temp, RPM L, RPM R, Manifold Pressure, Fuel Flow 1, Fuel Flow 2 (always 0).

GP Inputs

The output for GP input pins is:

- Each output is in the format +YYYYZ
 - + is the +/- sign for the value
 - YYYY is the value of the signal
 - Z is the units for the signal
 - C if the signal is in temperature, and the units are 1/10th degrees C
 - YYYY is 1/10th degrees C, so 1234 = 123.4 C
 - XXXX if the signal is out of range (red X on ems page)
 - ZZZZ if the input is not configured
 - P if the signal is in pressure, and the units are 1/10 PSI
 - YYYY is 1/10th PSI, so 0123 = 12.3 PSI
 - XXXX if the signal is out of range (red X on ems page)
 - ZZZZ if the input is not configured
 - G if the signal is in volume, and the units are 1/10th Gallons
 - YYYY is 1/10th gallons, so 0183 = 18.3 Gallons
 - XXXX if the signal is out of range or not calibrated (red X on ems page)
 - ZZZZ if the input is not configured
 - V if the signal is in volts (contact input)
 - YYYY is 1/100th volts, so 3852 = 38.52V
 - ZZZZ if the input is not configured
 - T if the signal is position
 - If elevator, rudder, and aileron trim, YYYY is percent travel, so 0047 = 47%
 - If flaps, this is the angle shown on the screen, so 0038 = 38 degrees
 - XXXX if the signal is out of range or not calibrated (red X on ems page)
 - ZZZZ if the input is not configured

As an example, the following is one (1) line of DYNON EMS serial output data:

```
!3221144705060+09323632363272057057164263263000280280+1200001300020+19  
7+592+197+592+197+592+197+592+197+592+197+592+197+197-  
0012T+0013T+0001T+0164P+1990P+0928C+0001T+0000G+0263G+0263G+0599P+0  
928C+0928CZZZZZZZZZZZZZZZZZZ045L26
```

33.4 DYNON ADAHRS / SYSTEM / EMS Serial Data Output Combinations

33.4.1 DYNON ADAHRS + SYSTEM Serial Data Format

DYNON ADAHRS+SYSTEM output data alternates between DYNON ADAHRS data and DYNON SYSTEM data. For example, the following is one (1) cycle of DYNON ADAHRS+SYSTEM serial output data where the first line is ADAHRS output and the next line is SYSTEM output:

```
!1121144703-014+00003310811+01736+003-03+1013-  
033+110831245+01650023176C
```

```
!2221144704359XXXXX1600+010XXX00XXXXXXXXXX00X0X+00-  
99990+00+99990+00XXXXX00104543XXXXXXXXXXX3A
```

33.4.2 DYNON ADAHRS + EMS Serial Data Format

DYNON ADAHRS+EMS output data alternates between DYNON ADAHRS data and DYNON EMS data. For example, the following is one (1) cycle of DYNON ADAHRS+EMS output data where the first line is ADAHRS output and that is followed by EMS output:

```
!1121144703-014+00003310811+01736+003-03+1013-  
033+110831245+01650023176C
```

```
!3221144705060+09323632363272057057164263263000280280+1200001300020+19  
7+592+197+592+197+592+197+592+197+592+197+592+197+197-  
0012T+0013T+0001T+0164P+1990P+0928C+0001T+0000G+0263G+0263G+0599P+0  
928C+0928CZZZZZZZZZZZZZZZZZZ045L26
```

33.4.3 DYNON ADAHRS + SYS + EMS Serial Data Format

DYNON ADAHRS+SYS+EMS output data alternates between DYNON ADAHRS data, DYNON SYSTEM data, and DYNON EMS data. For example, the following is one (1) cycle of DYNON ADAHRS+SYS+EMS serial output data where the first line is ADAHRS output, the second is SYSTEM output, and that is followed by EMS output:

```
!1121144703-014+00003310811+01736+003-03+1013-  
033+110831245+01650023176C
```

```
!2221144704359XXXXX1600+010XXX00XXXXXXXXXX00X0X+00-  
99990+00+99990+00XXXXX00104543XXXXXXXXXXX3A
```

```
!3221144705060+09323632363272057057164263263000280280+1200001300020+19  
7+592+197+592+197+592+197+592+197+592+197+592+197+197-  
0012T+0013T+0001T+0164P+1990P+0928C+0001T+0000G+0263G+0263G+0599P+0  
928C+0928CZZZZZZZZZZZZZZZZZZ045L26
```

33.5 NMEA OUT Serial Data Formats

NMEA output data consists of industry standard NMEA 0183 Version v4.00 sentences. A reference for Version 4.00 of the standard can be found here:

www.nmea.org/content/nmea_standards/nmea_083_v_400.asp

33.5.1 NMEA OUT (BASIC)

NMEA OUT (BASIC) serial output data consists of GGA, GSA, GSV, RMC, and VTG sentences nominally output at a rate of 1 Hz. The rate is reduced if necessary, to transmit the entire set of data at the selected baud rate. This format outputs GPS data for position, speed, altitude, and heading.

For example, the following is one (1) cycle of NMEA OUT (BASIC) serial output data:

```
$GPGGA,214921,3121.6199,N,00000.0000,E,1,04,1.90,3000.0,M,33.9,M,,0000*62
$GPGSA,A,3,01,02,03,04,00,00,00,00,00,00,00,1.00,1.90,1.90*07
$GPGSV,1,1,04,01,20,100,10,02,30,200,56,03,45,300,32,04,62,045,05*7A
$GPRMC,214921,A,3121.6199,N,00000.0000,E,82.07,1.00,300811,0.51,W,A*01
$GPVTG,1.00,T,0.51,M,82.07,N,151.99,K,A*1E
```

33.5.2 NMEA OUT (FULL)

NMEA OUT (FULL) data consists of all of the NMEA OUT (BASIC) sentences followed by RMB, GLL, BWC, XTE, BOD, and APB sentences nominally output at a rate of 1 Hz. The rate is reduced if necessary, to transmit the entire set of data at the selected baud rate. This format outputs navigation information derived by SkyView and is similar to the output that many handheld portable aviation GPS navigators generate.

For example, the following is one (1) cycle of NMEA OUT (FULL) serial output data:

```
$GPGGA,221755,3157.4430,N,00000.0000,E,1,04,1.30,3000.0,M,33.9,M,,0000*66
$GPGSA,A,3,01,02,03,04,00,00,00,00,00,00,00,1.00,1.30,1.40*00
$GPGSV,1,1,04,01,20,100,10,02,30,200,56,03,45,300,32,04,62,045,05*7A
$GPRMC,221755,A,3157.4430,N,00000.0000,E,82.07,1.00,300811,0.49,W,A*06
$GPVTG,1.00,T,0.49,M,82.07,N,151.99,K,A*17
$GPRMB,A,9.99,L,FHAW,TUPJ,1826.7333,N,06432.4998,W,999.9,273.6,005.1,V,A*41
$GPGLL,3157.4430,N,00000.0000,E,221755,A,A*42
$GPBWC,221755,1826.7333,N,06432.4998,W,273.6,T,274.1,M,999.9,N,TUPJ,A*67
$GPXTE,A,A,9.99,L,N,A*0A
$GPBOD,299.3,T,299.8,M,TUPJ,FHAW*4F
$GPAPB,A,A,9.99,L,N,V,V,299.8,M,TUPJ,274.1,M,274.1,M,A*4E
```

34 Appendix F: User Data Logs

SkyView continuously stores four (4) retrievable data logs that can be exported for user analysis. These data logs are stored on SkyView's internal flash memory and are exported to a USB flash drive.

The base file name is the same on all four (4) logs. Each element is separated by a dash (-) character:

- DATE – Expressed as year (-) 2-digit month – (2-digit day). Example 2015-01-14
- TAILNUMBER – As entered into SETUP MENU > SYSTEM SETUP > AIRCRAFT INFORMATION > TAIL NUMBER
- SKYVIEW DISPLAY SERIALNUMBER – The serial number of the SkyView display the data logs were recorded from.
- SOFTWARE VERSION – The Software version on the SkyView display that the data logs were recorded from, at the time of the data log export.
- OPTIONAL33 CHARACTERS – Optional 33 user-selectable characters that can be added to the data logs filename, selectable at the time of the data logs are exported.
- PART_XX – SkyView may save a data log into multiple files, distinguished by sequential digits, such asPART_01,PART_02, etc.

34.1 User Data Log

Filename format:

DATE-TAILNUMBER-SKYVIEWDISPLAYSERIALNUMBER-SOFTWAREVERSION-OPTIONAL33CHARACTERS-USER-LOG-DATA.csv

Example:

2014-08-07-N123X-SN1492-11.0-CROSS_COUNTRY_LEG1-USER_LOG_DATA.csv

(CROSS_COUNTRY_LEG1 is user-selectable text, up to 33 characters, at time of export.)

The User Data Log contains plain-text tabular data that records the entire state of your SkyView system at a recording rate of your choosing (see below). This includes over 100 items, and includes all ADAHRS (flight instrument) data, Engine parameters, GPS data, Autopilot status, SV-XPNDR-261 status, time, and more.

When exported, the data log is a standard CSV (comma separated value) file and can be viewed in spreadsheet programs such as Microsoft Excel once exported from the system. The top row of the CSV file is a header row which documents the format of the file. The headers for each configurable EMS input follow the following format: Name (Units) (where the "Name" field is as it is named in the SENSOR INPUT MAPPING setup menu). Each row beneath that header row contains an individual record – or instantaneous snapshot

– of all of the recorded fields. Because different SkyView systems have different EMS pin mappings, the order and content of the columns can be dynamic from system to system.

The User Data Log records at the selected Record Rate (see below) any time the SkyView system is powered on.

A sample of what a few columns and rows of data would look like when viewed in a spreadsheet program is shown below. An actual user data log would have over 100 columns of data, and many thousands of rows:

Table 89: User Data Log Excerpt Example

System Time	Pitch (deg)	Roll (deg)	Magnetic Heading (deg)	Indicated Airspeed (knots)	Pressure Altitude (ft.)
1:50:38	0.2	-1.7	134.4	0	4364
1:50:38	0.2	-1.8	134.4	0	4364
1:50:38	0.2	-1.8	134.3	0	4364
1:50:38	0.2	-1.8	134.4	0	4364
1:50:39	0.2	-1.8	134.4	0	4364
1:50:39	0.2	-1.7	134.4	0	4364

34.2 Recent Flight Data Log

Filename format:

2014-08-07-N123X-SKYVIEWDISPLAYSERIALNUMBER-SOFTWAREVERSION-
OPTIONAL33CHARACTERS-BLACK_BOX_LOG_DATA.csv

Example:

2014-08-07-N123X-SN1492-11.0-CROSS_COUNTRY_LEG1-
BLACK_BOX_LOG_DATA.csv

(CROSS_COUNTRY_LEG1 is user-selectable text, up to 33 characters, at time of export.)

The Recent Flight Data Log records the most recent 15 minutes of flight at a data recording rate of 16 times per second, in the same manner as described above. Its recording rate cannot be changed.

The Recent Flight Data Log records data whenever SkyView believes that it is in flight, which it determines by observing IAS and/or GPS ground speed.

34.3 Alert Data Log

Filename format:

DATE-TAILNUMBER-SKYVIEWDISPLAYSERIALNUMBER-SOFTWAREVERSION-
OPTIONAL33CHARACTERS-ALERT_DATA.csv

Example:

2014-08-07-N123X-SN1492-11.0-CROSS_COUNTRY_LEG1-ALERT_DATA.csv

(CROSS_COUNTRY_LEG1 is user-selectable text, up to 33 characters, at time of export.)

The Alert Data Log contains plain-text tabular data. A new record is appended each time a SkyView alert of any kind is triggered, including audible alerts and system messages. The Alert Data Log is useful for diagnosing alerts that automatically clear on a brief condition, for example, oil pressure going into the red zone for a few seconds, then back into green, and automatically clearing.

When exported, the data log is a standard CSV (comma separated value) file and can be viewed in spreadsheet programs such as Microsoft Excel once exported from the system. The top row of the CSV file is a header row which documents the format of the file. Each record consists of supporting data such as time, GPS data, type of alert, the type of alert action, and the description of the alert. The Alert Data Log is allocated 2 MB which may be sufficient to record more than 1500 hours of operation assuming as many as 10 alerts per hour. The Alert Data Log is not affected by the RECORD RATE setting below.

34.4 History Data Log

Filename format:

DATE-TAILNUMBER-SKYVIEWDISPLAYSERIALNUMBER-SOFTWAREVERSION-
OPTIONAL33CHARACTERS-HISTORY_LOG_DATA.csv

Example:

2014-08-07-N123X-SN1492-11.0-CROSS_COUNTRY_LEG1-
HISTORY_LOG_DATA.csv

(CROSS_COUNTRY_LEG1 is user-selectable text, up to 33 characters, at time of export.)

The History Data Log is a cumulative history of files loaded onto the SkyView and other changes mostly used for troubleshooting when requested from Dynon Avionics Technical Support.

34.5 Data Logging Recording Options

34.5.1 Record Rate

You can choose the frequency of the data that is recorded from SkyView's various systems for your particular needs. SkyView can record data as frequently as sixteen (16) times per second or as infrequently as once every ten (10) seconds. Recording more frequently trades off the amount of time that the data log covers. If you choose once every ten (10) seconds, SkyView's User Data Log can store up to about 150 hours of data. At sixteen (16) times per second, the log stores about two (2) hours of data. When the data log fills up, the oldest data is automatically discarded to make room for new data.

Navigate to SETUP MENU > SYSTEM SETUP > DATA LOG SETUP > RECORD RATE to choose the frequency that data is recorded to the internal User Data Log.

34.5.2 Clearing Data Logs

Navigate to SETUP MENU > SYSTEM SETUP > DATA LOG SETUP > CLEAR ALL DATA to erase the User Data Log, Recent Flight Data Log, and Alert Data Log. Note that this does not clear History Data Log, as this is a log of all significant changes to the configuration of the SkyView system.

34.5.3 Exporting Data Logs



In a dual engine configuration (dual SV-EMS-22x with at least two (2) SkyView displays), data logs for each engine are recorded / exported *only* on the display that is monitoring each engine. Example – in a system where the left display is configured to monitor the left engine, the data log exported from the left display contains the data log for the left engine (only). It is recommended to use a separate USB flash drive per engine to prevent the possibility of overwriting data logs.

Connect a USB flash drive with at least 100 MB of available storage capacity to your SkyView display. Then, navigate to SETUP MENU > SYSTEM SOFTWARE > EXPORT USER DATA LOGS to export the three (3) data logs to the USB flash drive.

If your SkyView system has not yet flown or has not flown since the data logs were last cleared, there may not be a Recent Flight Data Log available.

The data logs that are exported are in CSV (comma separated values) format and can be opened by common spreadsheet programs such as Microsoft Excel.

34.5.4 Web-based Engine Analysis

Savvy Analysis – <http://www.savvyanalysis.com> is a free web-based tool that supports the upload and analysis of the engine information that is contained within SkyView's User Data Logs. Instructions for creating an account and uploading data logs are on the Savvy Analysis website.

Other than technical cooperation to ensure that SkyView data logs can be correctly parsed as formats are periodically updated, Dynon Avionics has no relationship with Savvy Analysis.

35 Appendix G: Sensor Debug Data

If you have installed single, or dual SV-EMS-220s, SkyView can display the "raw data" from all connected and configured engine sensors to assist in troubleshooting engine sensor issues: SETUP MENU > EMS SETUP > SENSOR DEBUG DATA.



Figure 163: SENSOR DEBUG DATA Page

File Version

This is the sensor file version, with a revision number which should always be unique, as well as the date it was created at Dynon Avionics.

If you see an EMS SFG FILE MISMATCH warning, compare the file version between the two (2) displays and update one (1) display (load a new SFG file) so that both displays have the same File Version.

HB

"HeartBeat" – Increments steadily as data is received from the SV-EMS-220(s).

RC

"Resistor Control" – Status of the "pull up resistors" in the SV-EMS-220(s); Dynon Avionics internal use only.

Columns:

- **PIN**
 - C37 (Connector, 37-pin) – the 37-pin connector on the SV-EMS-220.
 - C25 (Connector, 25-pin) – the 25-pin connector on the SV-EMS-220.

- Px refers to an individual pin on the 37-pin or the 25-pin connector.
- Px/x refers to a pair of pins used for thermocouples (CHT/EGTs) on the 37-pin or the 25-pin connector.
- **NAME** – The name selected in SENSOR INPUT MAPPING for this sensor / input / pin.
- **SENSOR ID** – The type of sensor selected in SENSOR INPUT MAPPING for this sensor / input / pin.
- **RAW** – Raw number from the Analog to Digital converter; Dynon Avionics internal use only.
- **CAL(V)** – The exact voltage that is present on this pin. The output of many sensors is converted to a voltage in the SV-EMS-220 for processing. For example, Dynon Avionics temperature sensors are thermistors, which vary their resistance with changing temperature, and are converted to a voltage internally, before resulting in a display of temperature in ° Fahrenheit or ° Celsius.
- **VALUE** – Output of the (selected) sensor in (converted) units (such as pressure, temperature, etc.) corrected for the measurement unit selected (temperature in ° Fahrenheit, etc.). This is the same number that is displayed in the widget on the EMS page.
 - "NAN" is "Not A Number"; the input being received on this pin is invalid for this particular sensor. This is normal when the input is not configured, or the sensor is not connected or defective.

Specialized Function Pins

Pin 14

Primary fuel flow sensor, monitoring fuel flow from the tank to the engine. The RAW value will increment for every pulse received from the fuel flow sensor in the current boot cycle (reset when the SkyView display is powered off).

In the figure above, the displayed RAW value is shown as "5AD" (not 00000000). This value is displayed as a hexadecimal number (Base 16) and increments by 1 for each pulse. Succeeding pulses would change this value to 5AE, then 5AF, then 5B0, etc.

If the engine is on (fuel is flowing from the fuel tank to the engine), the RAW value should be incrementing. If the RAW value is not incrementing, no pulses are being received from the fuel flow sensor.

CAL(V) and VALUE both show the fuel flow rate, corrected for the "K-factor" selected in FUEL FLOW CALIBRATION (pulses per unit per hour) and the unit selected (Gallons or Liters).

Pin 19

Return fuel flow sensor, monitoring fuel flow from the engine back to the tank. The RAW value will increment for every pulse received from the fuel flow sensor in the current boot cycle (reset when the SkyView display is powered off).

Similarly, as Pin 14, in the figure above, the displayed RAW value is shown as "5AD" (not 00000000). This value is displayed as a hexadecimal number (Base 16) and increments by 1 for each pulse. Succeeding pulses would change this value to 5AE, then 5AF, then 5B0, etc.

If the engine is on (fuel is flowing from the engine back to the tank), the RAW value should be incrementing. If the RAW value is not incrementing, no pulses are being received from the fuel flow sensor.

Note that pulses received on Pin 14 are used to SUBTRACT from fuel flow monitored by Pin 14; pulses received on Pin 19 are subtracted from pulses received on Pin 14. For example, if 100 pulses are received on Pin 14, and 50 pulses are received on Pin 19, the net number of pulses used by the SkyView fuel computer to display actual fuel flow will use 50 "net" pulses.

CAL(V) and VALUE both show the fuel flow rate, corrected for the "K-factor" selected in FUEL FLOW CALIBRATION (pulses per unit per hour) and the unit selected (Gallons or Liters).

RPM Left – Pins C37 P32/34

Pin C37 Pin 32 and C37 Pin 34 are different signal levels to the RPM Left Input.

Pin 32 is used for standard (attenuated) signal (typically received from a magneto or other "high level" RPM output) for the RPM Left Input.

Pin 34 is used for low-voltage RPM signal (typically received from an Electronic Control Unit [ECU]).

RPM Right – Pins C37 P33/35

Pin C37 Pin 33 and C37 Pin 35 are different signal levels to the RPM Right Input.

Pin 33 is used for standard (attenuated) signal (typically received from a magneto or other "high level" RPM output) for the RPM Right Input.

Pin 35 is used for low-voltage RPM signal (typically received from an Electronic Control Unit [ECU]).

RPM Left – Pins C37 P32/34 and RPM Right – Pins C37 P33/35

Pin C37 P32/34 and Pin C37 P33/35 display an incrementing number in "RAW". Similar to what's shown in the figure above for Pin 14, the displayed RAW value is displayed as a hexadecimal number (Base 16) and increments by 1 for each pulse. Similar to the hexadecimal value shown for Pin 14, succeeding RPM pulses would change this value to 5AE, then 5AF, then 5B0, etc.

Thermocouples

Thermocouples (CHTs, EGTs) display as voltage in millivolts. .0084 is 84 millivolts, and which converts to 383 degrees F in a J type thermocouple.

Vref+ is an internal calibration voltage. If it's not near 5.00V in CAL(V) something in the voltage regulator circuitry is not operating correctly and will likely not read correctly.

Vdiff: Value should be near 100. This only affects thermocouples.

0diff: VALUE should be near 0.4. This only affects thermocouples.

ColdJ: Cold junction, which is the temp of the EMS box. VALUE should be the temp of the EMS box in degrees F. This only affects thermocouples.

36 Appendix H: Checklists

Personalized Checklists can be displayed in SkyView: TOOLS > CHECKLIST. Checklists cannot be displayed with earlier versions of SkyView Software.



Until a Checklist file is loaded into your SkyView system, the CHECKLIST button will not appear in the TOOLS menu.

SkyView Checklists are composed on a computer and then transferred to SkyView with a USB flash drive. Checklists can be composed with any text editor such as the "Notepad" app included with Microsoft Windows PCs, or the "TextEdit" app included with Apple Macs, *providing that the text editor can save the Checklist file using "UTF-8-character encoding"*. The "font" that your text editor application displays as you are composing your Checklist will not be used to display your Checklist on SkyView – your Checklist will be displayed in the standard "system font" used by SkyView to display text.



SkyView uses the "UTF-8-character encoding" standard to display text on the screen; thus, Checklist files, to properly display on SkyView, must also be "UTF-8 Character Encoding".

Although Microsoft Word and Microsoft WordPad will also work to compose a Checklist file, the "character encoding" for a Checklist file must be "UTF-8 Character Encoding" and when saving a file from Word or WordPad, it is difficult to ensure that the file is saved using "UTF-8 Character Encoding". If you do use Word or WordPad, before using your Checklist file on SkyView, open it in Windows Notepad or Mac OS TextEdit and save it per the instructions below.

The filename of your Checklist file should end in .txt. The filename should be made solely of alphanumeric characters, with no space in the name. Mixed case in the filename is acceptable. Examples:

- The filename "checklist.txt" is acceptable.
- The filename "chk1st.txt" is acceptable.
- The filename "checklist.text" is not acceptable (extension must be .txt).
- The filename "checklist" is not acceptable (there must be a .txt extension).
- The filename "check list.txt" is not acceptable (note the space between check and list).
- The filename "check%list" is not acceptable.

If you develop multiple Checklist files, it is recommended to begin a Checklist file with the word CHECKLIST, such as CHECKLIST01.txt, CHECKLIST02.txt, etc. This will allow all of your Checklist files to be grouped together and all Checklists easily seen on your USB flash drive when you are loading the Checklist into your SkyView display.



Although you can use mixed case in the Checklist filename, when selecting and loading your Checklist file onto SkyView, the Checklist filename will be displayed in UPPERCASE.

36.1 Saving Your Checklist with "UTF-8 Character Encoding"



When a Checklist file is (correctly) saved with "UTF-8 Character Encoding", any character will be *accepted* in the text of a Checklist (no error displayed). However, *some "unusual" characters may not be displayed*. All characters generated on a (Windows) keyboard, except the | character (shifted \), have been verified to display in a Checklist, as well as the following characters: € ‡ Œ • ¥ § © ® ° ± ¹ º » ¼ ½ ¾ × Ø ß ÷ ø Œ œ " " –
The following characters are (incorrectly) displayed as a box symbol: μ ^ v β

If a Checklist file is saved using another "Character Encoding" standard, such as "ANSI" (the default for Windows Notepad), use of certain characters will cause SkyView to not allow the file to be loaded (see figure below).

Mac TextEdit

Before working on your Checklist file in Mac OS TextEdit, follow steps 1-4 as illustrated in Figure 164 at right:

1. Click on **Preferences**.
2. Click on **New Document**.
3. Ensure the button **Plain text** is selected.
4. Ensure the box **Wrap to page** is not checked.
5. Change other settings per your preference.

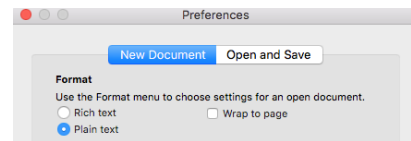

Figure 164: Mac TextEdit New Document Setup

Proceed to edit your Checklist in Text Edit.

After you have completed your Checklist, to save a Checklist file in Mac TextEdit using "UTF-8 Character Encoding", follow steps 6-10 as illustrated in Figure 165 at right:

6. Click on **Open and Save**.
7. Ensure the box **Add ".txt" extension to plain text files** is checked.
8. **Under Plain Text File Encoding**, pull down the **Saving Files:** menu.
9. Click on **Unicode (UTF-8)**.
10. **Unicode (UTF-8)** should now be checked.
11. Click on the Red button to close Preferences.

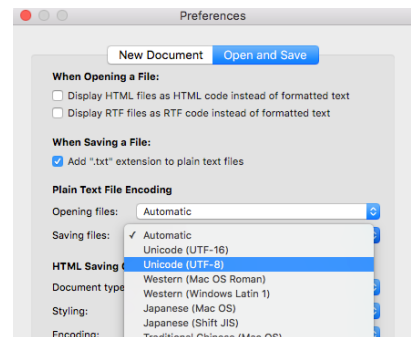

Figure 165: Mac TextEdit Set UTF-8 Encoding

Then, follow steps 13-18 as illustrated in Figure 166 at right (step 12 and step 19 not shown):

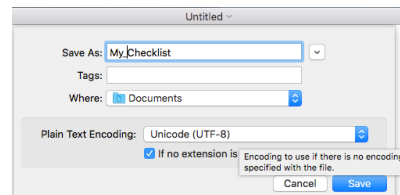

Figure 166: Mac TextEdit Save As Settings

12. On the TextEdit menu bar, click **File**, then **Save**.
13. Fill in **Save As:** with your checklist filename.
14. Ignore **Tags:**
15. Select the name of your USB flash drive (this is where you will save your Checklist file); example: **DYNON AVIONICS** or **KINGSTON**:
 - (older versions of Mac OS) Change **Where:** to the name of your USB flash drive.
 - (newer versions of Mac OS, **Where:** will not be shown) In the left column of the Finder, under **Devices**, click on (the name of) your USB flash drive.
16. Ensure **Plain Text Encoding:** is set to **Unicode (UTF-8)**.
17. Ensure the box for **If no extension is provided, use ".txt"** is checked.
18. Click the **Save** button.
19. In the left column of the Finder, next to the name of your USB flash drive, click on the "Eject button" to close all files on your USB flash drive before physically removing the USB flash drive from your Mac.

Windows Notepad

To save a Checklist file in Windows Notepad using "UTF-8 Character Encoding, follow these steps:

1. Click on **File**.
2. Click on **Save As...**
3. On the left side of the window, click on the drive letter of the USB flash drive. This will ensure that the Checklist file will be saved to the USB flash drive. Example: Drive F: (but your computer may assign a different drive letter).
4. **File Name:** (fill in your preferred filename for your Checklist file).
5. **Save as type:** Text Documents (*.txt).
6. **Encoding:** Pull down and select UTF-8.
7. Click the **Save** button.

Steps 4-7 are illustrated in Figure 167 below:

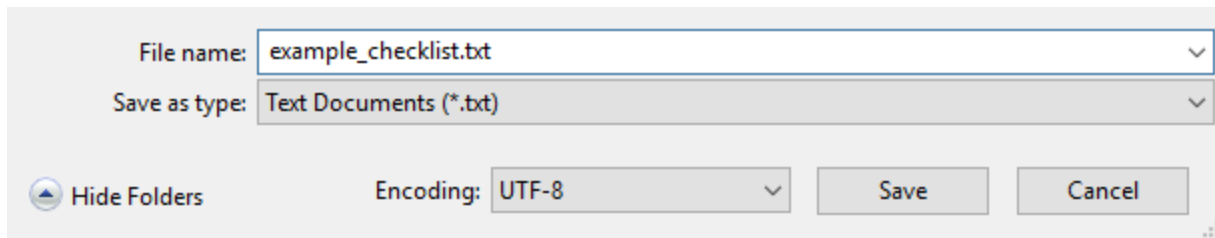

Figure 167: Windows Notepad Save As with UTF-8 Encoding

There can only be one (1) Checklist file loaded in a SkyView system at a time. It is not possible to have different Checklist files loaded onto different SkyView displays in a single SkyView system, such as a one (1) Checklist file for the Pilot's SkyView display and another Checklist file for the Co-Pilot's SkyView displays. If you desire to do so, create Checklist items for Pilot and Co-Pilot in a single Checklist and then work from different sections of that Checklist.

After you load a Checklist, it is stored in your SkyView display(s) non-volatile memory. As soon as a Checklist file is loaded onto a SkyView display, the Checklist is synchronized with all other SkyView displays in your SkyView system. After your Checklist is loaded, you can remove the USB flash drive from your SkyView display; the USB flash drive does not have to remain inserted in order to access your Checklist.

When you load a new Checklist file into a SkyView display, it will overwrite the Checklist that was previously stored (if any) in SkyView's memory; there is no way to retrieve an overwritten Checklist. If you have one (1) of your SkyView displays powered off, the SkyView display that was powered up (that you loaded the Checklist into), will synchronize the Checklist file with the powered off SkyView display as soon as the display is powered up.

Checklists in a SkyView display are saved / exported (along with other files):
SETUP MENU > EXPORT SETTINGS > (one (1) more right click)
The filename of your Checklist will be (tail number, version, etc.)_CHECKLISTS.TXT

36.2 Example Checklist



This entire example Checklist (of which only a portion is shown here) can be downloaded from dynon.com/download.

```
# LINES THAT BEGIN WITH # ARE COMMENT LINES AND WILL NOT BE
DISPLAYED IN THE CHECKLIST
# LINES ARE 31 CHARACTERS LONG ON A SKYVIEW 40 PERCENT PAGE
# LINES ARE 40 CHARACTERS LONG ON A SKYVIEW 50 PERCENT PAGE
# LINES WITH MORE CHARACTERS THAN ABOVE ARE NOT WRAPPED AND
WILL NOT SHOW
# SV_Checklist_Template_Rev_A.txt

CHKLST0.TITLE, PRE-FLIGHT
CHKLST0.LINE1,
CHKLST0.LINE2, BUILD YOUR CHECKLIST HERE
```

CHKLST1.TITLE, BEFORE STARTING ENGINE
 CHKLST1.LINE1,
 CHKLST1.LINE2, BUILD YOUR CHECKLIST HERE

CHKLST2.TITLE, ENGINE START
 CHKLST2.LINE1,
 CHKLST2.LINE2, BUILD YOUR CHECKLIST HERE

CHKLST3.TITLE, PRE-TAXI & TAXI
 CHKLST3.LINE1,
 CHKLST3.LINE2, BUILD YOUR CHECKLIST HERE

CHKLST4.TITLE, RUN-UP & PRE-TAKEOFF
 CHKLST4.LINE1,
 CHKLST4.LINE2, BUILD YOUR CHECKLIST HERE

...

CHKLST21.TITLE, MISC: TRANSPONDER CODES
 CHKLST21.LINE1,
 CHKLST21.LINE2, VFR - 1200 (USA)
 CHKLST21.LINE3, VFR - 7000 (Europe)
 CHKLST21.LINE4, Hijack – 7500
 CHKLST21.LINE5, Radio Fail – 7600
 CHKLST21.LINE6, Emergency - 7700

36.3 Example Checklist Formatting Notes:

Comment lines (not displayed as a Checklist item) begin with #. Example:

This line in a checklist file will not be displayed in a checklist.

Checklist numbering starts with 0; the first Checklist displayed is CHKLST0.

For additional Checklists, increment the name CHKLST in each section from 0. Example:

- CHKLST0
- CHKLST1
- CHKLST10
- CHKLST11
- (etc.)

Each Checklist requires a title line in this format:

CHKLST(section number).TITLE, (title). Example:
 CHKLST0.TITLE, PRE-FLIGHT

Each Checklist can have any number of Checklist items (including none), but each item must be sequentially numbered, beginning from 1, in this format:

CHKLST(section number).LINE(checklist item), (title). Example:
CHKLST0.LINE1,
CHKLST0.LINE2, BUILD YOUR CHECKLIST HERE

Each Checklist Name and Checklist Item will only display 31 characters for a 40% Page, and 40 characters on a 50% page. Characters in excess of these lengths will not be wrapped and will simply not appear.

LINES ARE 31 CHARACTERS LONG ON A SKYVIEW 40 PERCENT PAGE
LINES WITH MORE CHARACTERS THAN ABOVE ARE NOT WRAPPED AND WILL NOT SHOW
CHKLST0.TITLE, 1234567890123456789012345678901
CHKLST0.LINE1, 1234567890123456789012345678901

LINES ARE 40 CHARACTERS LONG ON A SKYVIEW 50 PERCENT PAGE
LINES WITH MORE CHARACTERS THAN ABOVE ARE NOT WRAPPED AND WILL NOT SHOW
CHKLST0.TITLE, 1234567890123456789012345678901234567890
CHKLST0.LINE1, 1234567890123456789012345678901234567890

If you wish to keep track of the version of Checklist that you develop, this is easily done by making the title of your last Checklist a version number (with no Checklist items), such as:

CHKLST23.TITLE, CHECKLIST INFO
CHKLST23.LINE1,
CHKLST23.LINE2, LAST UPDATED 2016-01-12
CHKLST23.LINE3, (DATE MUST BE MANUALLY UPDATED)

This will appear on the last line of the Checklist as:

CHECKLIST INFO >

When you click the arrow:

LAST UPDATED 2016-01-12

(DATE MUST BE MANUALLY UPDATED)

36.4 Excel Checklist Generation Tool



Dynon Avionics has developed a SkyView Checklist Generation Tool based on Excel for Mac or PC; this tool will not work in the versions of Excel accessible online or in versions of Excel on tablet devices (these versions do not have "macro" capability). Using this tool is easier than creating a Checklist manually in a text editor, allowing you to focus on the contents of your Checklist. The tool ensures that the formatting of the Checklist is correct. The tool requires that your computer have Microsoft Excel installed as it uses Excel's macro capability to perform the formatting.

The tool is called "Excel-based Checklist Creator" and can be downloaded from dynon.com/download. Dynon Avionics has also released a video tutorial

for this tool, available on the Dynon Avionics Channel section of YouTube – youtube.com/DynonAvionics.

36.5 Loading a Checklist

After you have saved your Checklist file from your computer to your USB flash drive, take the USB flash drive to your aircraft. After your SkyView display is powered up, push buttons 7+8 to access the SETUP MENU. Then:

SETUP MENU > SYSTEM SOFTWARE > LOAD FILES > (select your Checklist file) > LOAD (button) > YES (button) >

If your Checklist file did not have any errors, you will see the following screen:



Figure 168: Checklist File Loaded Successfully

If your Checklist file had a formatting or other error, you will see the following screen:



Figure 169: Checklist File Has an Error, Line Number Displayed, Could Not Be Loaded

In SkyView Software v14.1, if a checklist file being loaded has an error, the line number(s) of the checklist file with the error is listed.

Once loaded onto one (1) SkyView display, a Checklist is synchronized to all other SkyView displays and the Checklist can be displayed on any, or all, of the SkyView displays.

Troubleshooting Your Checklist File

Ensure that your SkyView system has been updated to Software v14.0 (or later); support for Checklists was added in Software v14.0.

For troubleshooting a Checklist, use of Software v14.1 is recommended as that version will display the line numbers of any errors encountered (as shown in Figure 169).

If you have a complex checklist, use of a text editor that displays line numbers is recommended.

The most common problem with Checklist files not loading correctly onto a SkyView display is that the Checklist file was not saved using "UTF-8 Character Encoding". If your Checklist file will not load, try opening it and re-saving it in Windows Notepad or Mac OS TextEdit using the procedure shown above – Saving Your Checklist with "UTF-8 Character Encoding", and see Figure 167: Windows Notepad Save As with UTF-8 Encoding, or Figure 164, Figure 165, and Figure 166 above for Mac OS TextEdit.

If your Checklist will still not load, then, check that each section (each individual Checklist) begins with the same CHECKLIST(number). Example:

CHKLST0.TITLE, PRE-FLIGHT
 CHKLST0.LINE1,
 CHKLST0.LINE2, BUILD YOUR CHECKLIST HERE
 is correct.

CHKLST0.TITLE, PRE-FLIGHT
 CHKLST0.LINE1,
 CHKLST1.LINE2, BUILD YOUR CHECKLIST HERE
 is not correct (Checklist numbers do not match).

Also, check that each Checklist item) has a correct, sequential number. Example:
 CHKLST0.TITLE, PRE-FLIGHT
 CHKLST0.LINE1
 CHKLST0.LINE2, BUILD YOUR CHECKLIST HERE
 is correct.

CHKLST0.TITLE, PRE-FLIGHT
 CHKLST0.LINE1,
 CHKLST0.LINE1, BUILD YOUR CHECKLIST HERE
 is not correct (there are two (2) CHKLST0.LINE1 lines; the second should be
 CHKLST0.LINE2).

If you cannot get your Checklist file to load ("FILE HAS ERROR" screen), you can isolate where the problem is in your Checklist file by "commenting out" individual lines, or entire sections, by prepending the line with a # and a space character. Example:

CHKLST0.TITLE, PRE-FLIGHT

A future version of SkyView Software will enhance the error message shown in Figure 169 above to display the line number where an error is encountered.

Lines that begin with # will not be processed / checked when the Checklist file is loaded. Admittedly this will be tedious if your SkyView display is in your aircraft and your computer is at home, so this is best done using a laptop computer in the aircraft, so you can edit, export, and test rapidly on your SkyView display.

Once a Checklist is loaded, there is no way to delete the current Checklist. The closest thing to a "delete Checklists" function is to load an empty file (no text in it) with a filename such as blankchecklist.txt. This will have the effect of displaying a blank page when the CHECKLIST button is pressed.

36.6 Displaying Your Checklist on your SkyView Display



Until a Checklist file is loaded into your SkyView system, the CHECKLIST button will not appear in the TOOLS menu. A default / example Checklist is not installed in new SkyView displays, nor is a default / example Checklist automatically installed into a SkyView display as part of updating your SkyView system to Software v14.0.

To access your Checklist on a SkyView display, from the main menu, go to the TOOLS menu and push the CHECKLIST button. The Checklist will continue to be displayed until

the CHECKLIST button is pressed again (the CHECKLIST button "toggles" the display of your Checklist On and Off).

Your Checklist will be displayed on the SkyView display in a 40% window or 50% window per the following conditions:

- The Checklist will not obscure the PFD
- If the display is set to display 100% PFD, MAP, or EMS, the original page will be resized to 50% and the Checklist will be displayed at 50%.
 - If the Checklist displays at 40% on a 100% page, temporarily enable another page, select the 50% / 50% layout, then disable the temporary page. The Checklist should now correctly display at 50%.
- If the display is set to display 60% PFD / 40% MAP or EMS, the MAP or PFD (40% page) will be replaced with the Checklist (displayed at 40%).
- If the display is set to display MAP and EMS (any % of either), the EMS page will be resized to 50% and the Checklist will be displayed at 50%.



Figure 170: List of Checklists Available



Figure 171: Example Pre-Flight Checklist

The Checklist will continue to be displayed until the CHECKLIST button is pressed again (the CHECKLIST button "toggles" the display of your Checklist On and Off).

37 Appendix I: Switches, Controls, Etc. External to SkyView Units

Some SkyView units provide inputs or outputs for switches, other controls, indicators, etc. that are installed external to the SkyView unit. Some of these are required (such as Servo Disconnect / CWS), while others provide optional, additional functionality. The table below provides a comprehensive listing of all external switches, etc. for reference in planning a SkyView panel, stick grip, hat switches, etc.



Detailed installation instructions for the switch or indicator are included in the section of this manual that the button, switch, or indicator is connected to.

Table 90: Switches, etc. External to SkyView Units

SkyView Unit	Function	Pin Number	Wire Color	Notes
Servo(s): SV32(x) SV42(x) SV52(x)	Servo Disconnect / Control Wheel Steering (CWS) button	3	Yellow	Push Button Normally Open (PBNO).
SV-AP-PANEL	Pilot Trim Up Button	3	N/A	Push Button Normally Open (PBNO).
	Pilot Trim Down Button	4		
	Copilot Trim Up Button	5		
	Copilot Trim Down Button	6		
	Pilot Trim Right Button	10		
	Pilot Trim Left Button	11		
	Copilot Trim Right Button	12		
	Copilot Trim Left Button	13		
SV-COM-PANEL	Flip/Flop	7	N/A	Push Button Normally Open (PBNO).
SV-COM-X25/X83	Push To Talk (PTT)	15	N/A	Push Button Normally Open (PBNO)
SV-EMS-220	EMS Warning Indicator	29	Yellow/Green	Indicator.
SV-XPNDR-261	Standby	17	N/A	Single Pole Single Throw (SPST) Switch.
	Ident Pushbutton	20	N/A	Push Button Normally Open (PBNO).